



Endicott Research Group, Inc.

2601 Wayne St., Endicott, NY 13760
 607-754-9187 Fax 607-754-9255
<http://www.ergpower.com>

P55WD3151

Single Tube
 DC to AC Inverter

Specifications and Applications Information

06/25/04

Preliminary

The ERG P55WD Series of inverters was specifically designed for wide temperature applications. With an internal PWM generator these inverters are capable of wide range dimming in response to an analog input.

Powered by a regulated +5 volt DC source, the P55WD3151 is designed to power the Sharp LQ070Y5DG02 display.

- ✓ High Efficiency
- ✓ High Current Option for Cold Starts
- ✓ Fully Encapsulated
- ✓ Integrated PWM with Analog Control
- ✓ Designed, Manufactured and Supported in the USA
- ✓ One Year Warranty

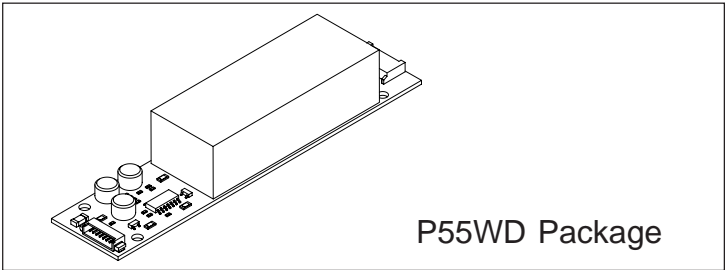

P55WD Package

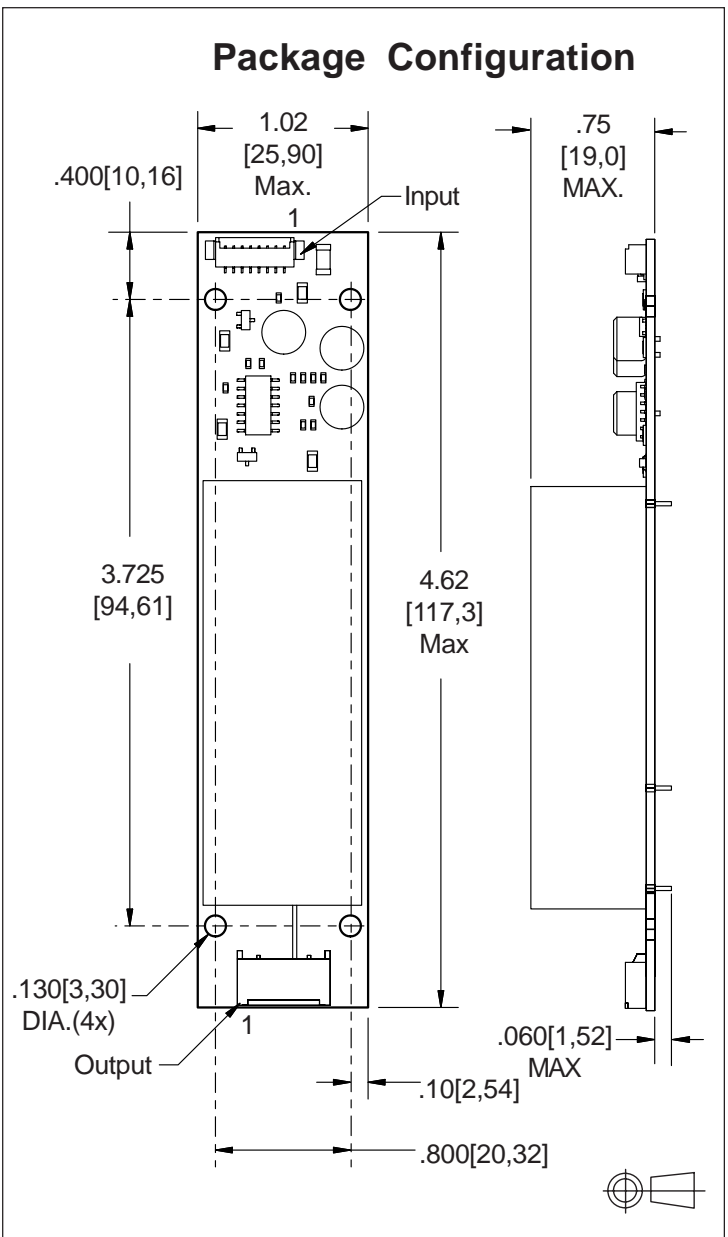

Pin Descriptions		
Input connector Molex 53261-0890		Output connector JST SM02(8.0)B-HS-1-TB
J1-1,2	Vin	J1-1 ACout
J1-3,4	GND	J1-2 N/C
J1-5	Control 0 = Full On +4.5 = Full Off	J1-3 ACout
J1-6	Enable 0 = Full Off +5 > = Enable	
J1-7,8	GND	

P55WD3151

Absolute Maximum Ratings (Note 1)

Rating	Symbol	Value	Units
Input Voltage Range	Vin	-0.3 to +5.5	Vdc
Operating Temperature <small>(Note 2)</small>	To	-30 to +85	°C
Storage Temperature	Tstg	-40 to +85	°C

Recommended Operating Conditions

Rating	Symbol	Value	Units
Input Voltage	Vin	+4.50 to 5.25	Vdc

Electrical Characteristics

Unless otherwise noted Vin = 5.00 Volts dc and Ta = 25°C

Characteristic	Symbol	Min	Typ	Max	Units
Input Current	Iin	-	1.1	1.3	Adc
Operating Frequency	Fo	25	30	35	KHz
Output Voltage (no load)	Vstart (min)	2200	-	-	Vac rms
Efficiency	-	-	82	-	%
Output Current per tube <small>(Note 3)</small>	Iout	0	6	-	mAac rms
Output Voltage (with load) (When powering the referenced display)	Vout	-	750	-	Vac rms
Enable (pin J1- 6)					
Turn-Off Threshold	V thoff	-	-	1	Vdc
Turn-On Threshold	V thon	2.5	-	5.5	Vdc
Impedence to Vin	Renable	9.5	10	10.5	Kohm

(Note 1) Reliable and predictable operation of the device are not guaranteed with applied stresses at or beyond those listed in "Absolute Maximum Ratings". Operation at these limits may reduce device reliability and is therefore not recommended. Please refer to "Recommended Operating Conditions" for reliable operation of the device.

(Note 2) Operation above 50°C is possible if airflow is provided.

(Note 3) See Application Notes on page 3.



Endicott Research Group, Inc.

2601 Wayne St., Endicott, NY 13760

607-754-9187 Fax 607-754-9255

<http://www.ergpower.com>



Onboard PWM

Unless otherwise noted $V_{in} = 5.00$ Volts DC , $T_a = 25$ °C and unit has been running for 5 minutes.

Characteristic	Symbol	Min	Typ	Max	Units
Frequency	f_{pwm}	-	170	-	Hz
Control Input Bias Current	I_{cbias}	-	-	10	uA

Pin Descriptions

- Vin** Input voltage to the inverter. The two pins should be connected for optimum reliability and efficiency.
- GND** Inverter ground. The four pins should be connected for optimum reliability and efficiency.
- Control** Analog voltage input to the onboard pulse width modulator. Decreasing this voltage increases the ON time of the onboard PWM resulting in increased brightness. The inverter is full ON when this voltage is near inverter ground.
- Enable** Inverter Enable. Pull this pin low to disable inverter operation. This pin must be high to enable the inverter. The onboard PWM is always utilized.

Application Notes

The P55WD series is designed to power one or two cold cathode fluorescent lamps. Dimming is accomplished either with an external analog control signal or an external PWM signal.

External Analog Dimming: An external analog control signal is applied to the Control Pin to enable an internal pulse width modulator. Figure 1 shows how to connect the inverter for external analog dimming. Graph 1 shows the relationship between the Control Pin voltage and the PWM Duty Cycle. Adequate Control Pin current must be provided per the table in this datasheet.

External PWM Dimming: If external PWM dimming control is required, an external PWM signal is interfaced to the inverter through the Enable Pin. With external PWM dimming the Control Pin must be connected to inverter ground. The external PWM signal should be 160-250Hz with duty cycle variable from 0% to 100%.

High Current Control For Lamp Warm-up: If the output current per tube shown on page two of this datasheet is greater than that in the display specification then the inverter has been designed for a higher than specified current to enhance lamp warm-up. After lamp warm-up, the PWM duty cycle must be reduced to provide input power consistent with the CCFL rating. Determination of warm-up time and duty cycle reduction is the responsibility of the end user. Failure to follow this application note may void warranty on the LDB and/or inverter.

Printed Circuit Board:

- 1) Printed circuit boards should be free of traces beneath the inverter.
- 2) The minimum distance from high voltage areas of the inverter to any conductive material should be .12 inches per kilovolt of starting voltage.
- 3) Contact ERG for possible exceptions.

Contact ERG for any application questions



P55WD3151

Figure 1: Connection Diagram

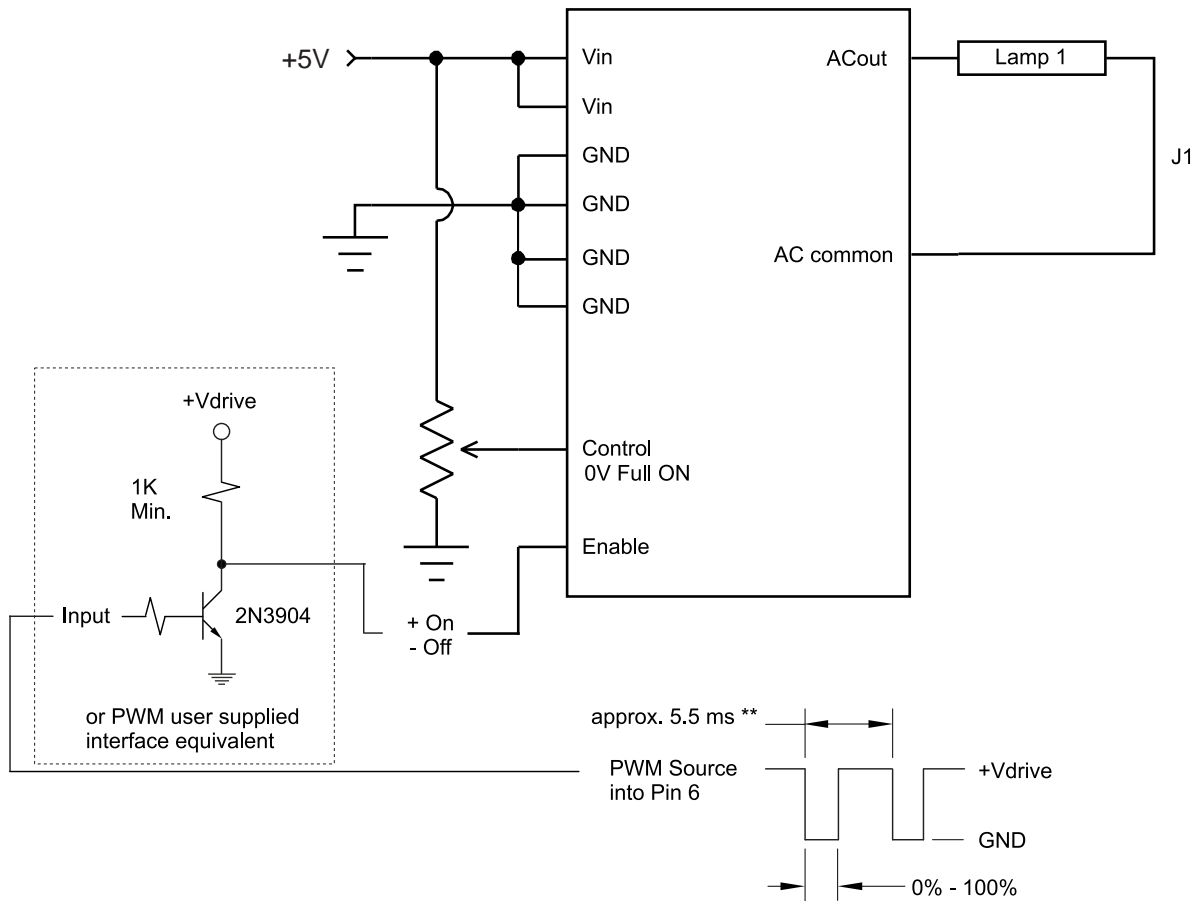

** Should be selected to be compatible with LCD and display driver.

Graph 1

Control Voltage vs. Duty Cycle

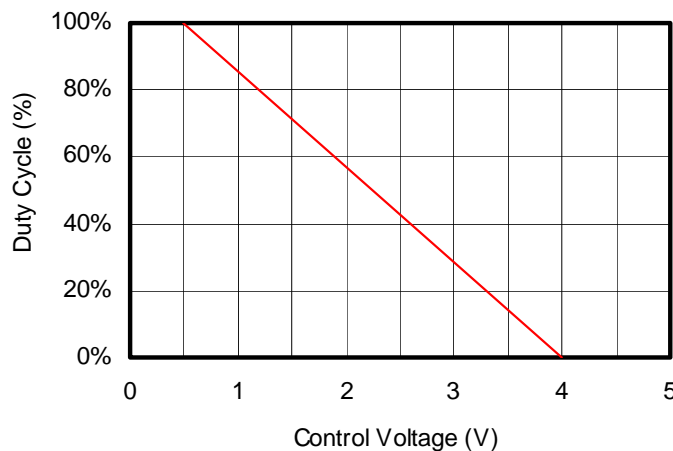

Endicott Research Group, Inc. (ERG) reserves the right to make changes in circuit design and/or specifications at any time without notice. Accordingly, the reader is cautioned to verify that data sheets are current before placing orders. Information furnished by ERG is believed to be accurate and reliable. However, no responsibility is assumed by ERG for its use.