



Endicott Research Group, Inc.

2601 Wayne St., Endicott, NY 13760
607-754-9187 Fax 607-754-9255
http://www.ergpower.com

P55W2840

Specifications and Applications Information

06/25/04

Preliminary

Single Tube
DC to AC Inverter

The ERG P55W Series of inverters was specifically designed for wide temperature applications. With an external PWM generator and software control, these are capable of obtaining the high currents and starting voltages of high pressure lamps seen in automotive OEM environments.

Powered by a regulated +12 volt DC source, the P55W2840 is designed to power the LG Phillips LB070W01-A1 display.

- ✓ PCB Mountable
- ✓ High Efficiency
- ✓ High Current Operation for Cold Starts
- ✓ Designed for High Pressure Automotive Type Lamps
- ✓ Fully Encapsulated
- ✓ External Control and PWM Dimming
- ✓ Designed, Manufactured and Supported in the USA
- ✓ One Year Warranty



P55W Package

Package Configuration

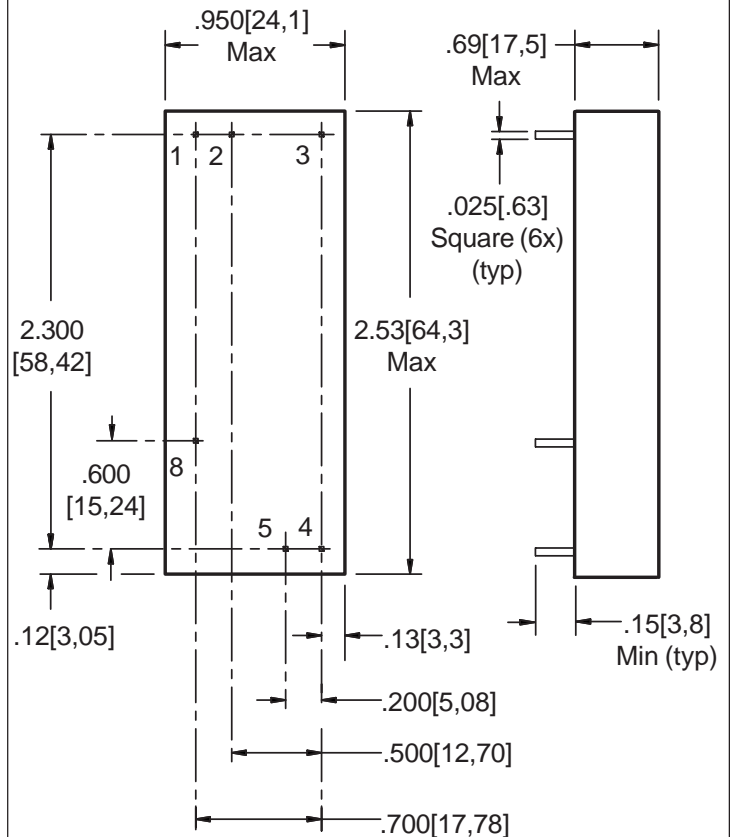

Inverter shown with pins pointing up.

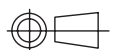

Pin Descriptions

J1-1 Vin
 J1-2 GND
 J1-3 Enable/PWM
 J1-4 ACout
 J1-5 N/C
 J1-8 ACcommon

P55W2840

Absolute Maximum Ratings (Note 1)

Rating	Symbol	Value	Units
Input Voltage Range	Vin	-0.3 to +15	Vdc
Operating Temperature <small>(Note 2)</small>	To	-30 to +85	°C
Storage Temperature	Tstg	-40 to +85	°C

Recommended Operating Conditions

Rating	Symbol	Value	Units
Input Voltage	Vin	+10.8 to 12.6	Vdc

Electrical Characteristics

Unless otherwise noted Vin = 12.00 Volts dc and Ta = 25°C

Characteristic	Symbol	Min	Typ	Max	Units
Input Current	Iin	-	.50	.58	Adc
Operating Frequency	Fo	24	29	34	KHz
Output Voltage (no load)	Vstart (min)	2120	-	-	Vac rms
Efficiency	-	-	91	-	%
Output Current per tube <small>(Note 3)</small>	Iout	0	6.3	-	mAac rms
Output Voltage (with load) (When powering a load equivalent to the referenced display)	Vout	-	870	-	Vac rms
Enable/PWM Control (pin J1- 3)					
Turn-Off Threshold	V thoff	4	-	13.2	Vdc
Turn-On Threshold	V thon	GND	-	.8	Vdc
Input Impedance	Renable	9.5	10	10.5	Kohm

(Note 1) Reliable and predictable operation of the device are not guaranteed with applied stresses at or beyond those listed in "Absolute Maximum Ratings". Operation at these limits may reduce device reliability and is therefore not recommended. Please refer to "Recommended Operating Conditions" for reliable operation of the device.

(Note 2) Operation above 50°C is possible if airflow is provided.

(Note 3) See Application Notes on page 3.



Endicott Research Group, Inc.

2601 Wayne St., Endicott, NY 13760

607-754-9187 Fax 607-754-9255

<http://www.ergpower.com>



The P55W series is designed to power one or two cold cathode fluorescent lamps. Dimming and external shut down is accomplished with an external PWM signal.

External PWM Dimming: If external PWM dimming control is required, an external PWM signal is interfaced to the inverter through the Enable Pin. The external PWM signal should be 160-250Hz with duty cycle variable from 0% to 100%.

Enable: If no dimming is required, the inverter is turned on/off through the Enable Pin. Applying an Enable Pin voltage below V_{thon} enables the inverter and applying a voltage above V_{thoff} disables the inverter.

High Current Control For Lamp Warm-up: If the output current per tube shown on page two of this datasheet is greater than that in the display specification then the inverter has been designed for a higher than specified current to enhance lamp warm-up. After lamp warm-up, the PWM duty cycle must be reduced to provide input power consistent with the CCFL rating as shown in Figure 2. Determination of warm-up time and duty cycle reduction is the responsibility of the end user. Failure to follow this application note may void warranty on the LDB and/or inverter.

Printed Circuit Board:

- 1) Printed circuit boards should be free of traces beneath the inverter.
- 2) The minimum distance from high voltage areas of the inverter to any conductive material should be .12 inches per kilovolt of starting voltage.
- 3) Contact ERG for possible exceptions.

Contact ERG for any application questions

Figure 1: Connection Diagram

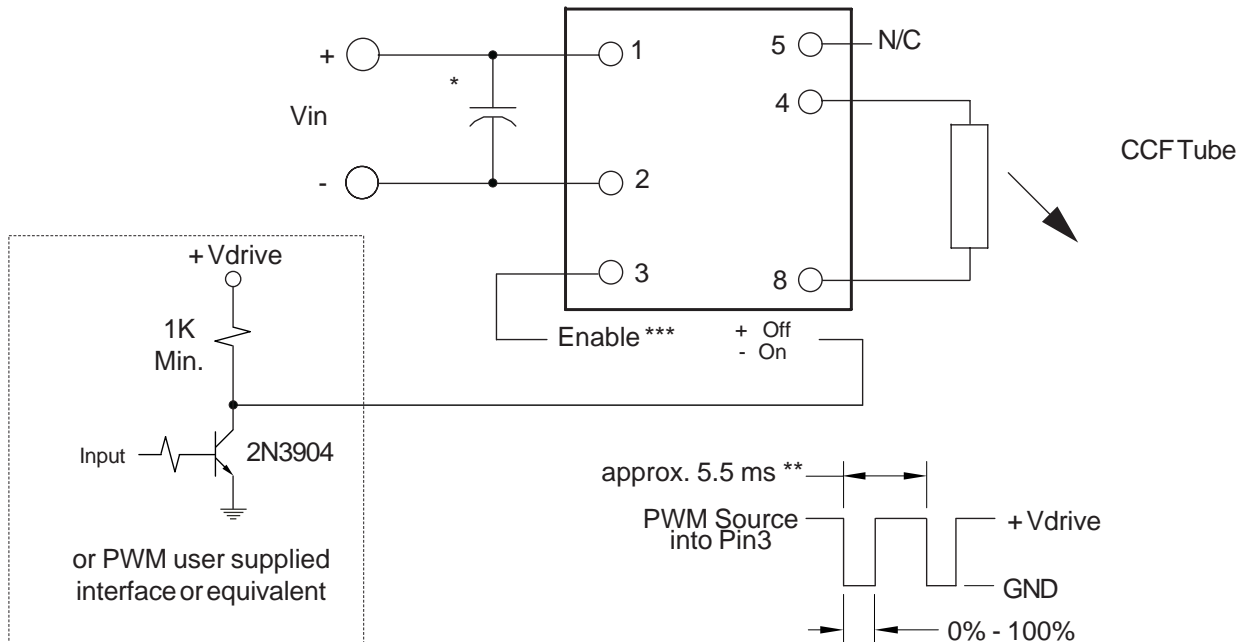

* Input bypass capacitor may be required (10uf - 100uf).

** Should be selected to be compatible with LCD and display driver.

*** If a PWM Source is not used the Enable (pin 3) must be at ground to hold the inverter on.



Endicott Research Group, Inc. (ERG) reserves the right to make changes in circuit design and/or specifications at any time without notice. Accordingly, the reader is cautioned to verify that data sheets are current before placing orders. Information furnished by ERG is believed to be accurate and reliable. However, no responsibility is assumed by ERG for its use.