



Endicott Research Group, Inc.

2601 Wayne St., Endicott NY 13760

607-754-9187 Fax 607-754-9255

http://www.ergpower.com

Specifications and Applications Information

09/19/00

Preliminary

The ERG MC2C2390 (MC Series) DC to AC inverter features onboard connectors and can be easily dimmed using an external pulse-width modulated control signal or using the onboard PWM with an external analog voltage. This unit is only 17mm in height and the four mounting holes makes installation very straight forward.

Powered by a regulated 12 Volt DC source, the MC2C2390 is designed to power the eight tube Landmark LM110A-12TX31 or LM114A-12DG11 backlights.

Product Features

- ✓ Small Package Size, less than 17mm in height.
- ✓ High Dimming Ratio (Greater than 1000:1)
- ✓ High Efficiency
- ✓ Made in U.S.A.

This unit complements our R Series of DC to AC Inverters

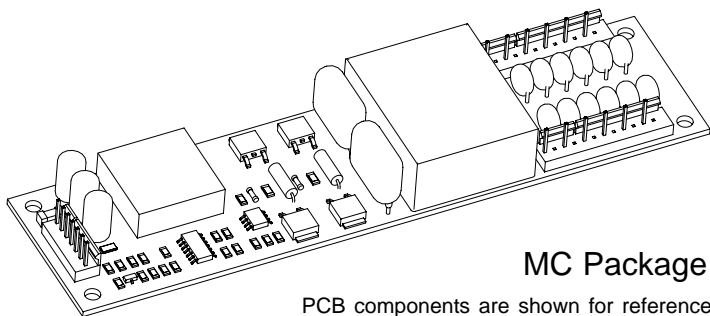

MC Package

PCB components are shown for reference only. Actual product may differ from that shown.

Connectors

J1	J2	J3
Molex 22-23-2071	Molex 22-23-2111	Molex 22-23-2111

MC2C2390

Eight Tube DC to AC Inverter

Package Configuration

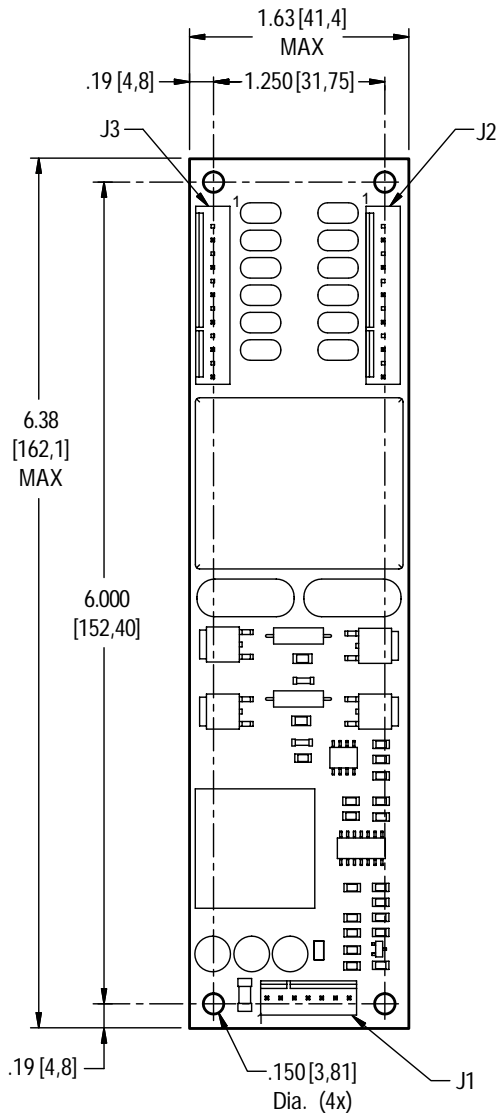

PCB components are shown for reference only. Actual product may differ from that shown.

Mass: 77 grams

Pinouts

J1-1 Vin	J2-1 NC	J3-1 NC
J1-2 Vin	J2-3 NC	J3-3 NC
J1-3 GND	J2-5 Lamp	J3-5 Lamp
J1-4 GND	J2-7 Lamp	J3-7 Lamp
J1-5 Control	J2-9 Lamp	J3-9 Lamp
J1-6 Disable	J2-11 Lamp	J3-11 Lamp
J1-7 PWMOut	J2-13 AC com.	J3-13 AC com.



Absolute Maximum Ratings (Note 1)

Rating	Symbol	Value	Units
Input Voltage	V_{in}	-0.3 to +15	V_{DC}
Disable	$V_{Disable}$	-0.3 to $V_{in} + 0.3$	V_{DC}
Control	$V_{Control}$	-0.3 to $V_{in} + 0.3$	V_{DC}
Operating Temperature	T_a	0 to +85	°C
Storage Temperature	T_s	-40 to +85	°C

Recommended Operating Conditions

Rating	Symbol	Value	Units
Input Voltage	V_{in}	10.8 to 13.2	V_{DC}
Operating Temperature <small>(Note 2)</small>	T_a	0 to +50	°C

Electrical Characteristics

Unless otherwise noted $V_{in} = 12.00$ Volts DC , $T_a = 25$ °C and unit has been running for 20 minutes.

Characteristic	Symbol	Min	Typ	Max	Units
Inverter					
Input Current	I_{in}	-	1.80	2.10	A_{DC}
Input Ripple Current	I_{rip}	-	100	-	mA _{pk-pk}
Operating Frequency	F_o	33	38	43	KHz
Efficiency	η	-	88	-	%
Output Voltage (no load) <small>(Note 3)</small>	V_{start}	1300	-	-	V
Output Voltage (with lamp)	V_{out}	-	470	-	V
Output Current (per tube)	I_{out}	-	6.0	-	mArms
Disable (pin J1-6)					
Turn-Off Threshold	V_{thoff}	-	-	2	V
Turn-On Threshold	V_{thon}	4	-	-	V
Impedance to V_{in}	$R_{Disable}$	9.5	10.0	10.5	kOhms

(Note 1) Reliable and predictable operation of the device is not guaranteed with applied stresses at or beyond those listed in "Absolute Maximum Ratings". Operation at these limits may reduce device reliability and is therefore not recommended. Please refer to "Recommended Operating Conditions" for reliable operation of the device.

(Note 2) Reliable operation above 50°C is possible if airflow is provided.

(Note 3) Provided data is not tested but guaranteed by design.



Onboard PWM

Unless otherwise noted $V_{in} = 12.00$ Volts DC , $T_a = 25$ °C and unit has been running for 20 minutes.

Characteristic	Symbol	Min	Typ	Max	Units
Frequency	f_{pwm}	-	160	-	Hz
PWM Output High	V_{pwmoh}	8.0	-	-	V
PWM Output Low	V_{pwmol}	-	-	0.8	V
Control Input Bias Current	I_{cbias}	-	-	10	uA

Pin Descriptions

- Vin** Input voltage to the inverter. Both pins should be connected for optimum reliability and efficiency .
- GND** Inverter ground. Both pins should be connected for optimum reliability and efficiency.
- Control** Analog voltage input to the onboard pulse width modulator. Increasing this voltage increases the off time of the onboard PWM resulting in decreased brightness.
- Disable** Inverter disable. Pull this pin low to disable inverter operation. If this pin is left floating or driven high, the inverter is enabled. If the onboard PWM is utilized, connect this pin to PWMOUT.
- PWMOUT** Output of the onboard PWM generator.

Application information

The MC series of inverters is designed to power up to twelve cold cathode fluorescent tubes with combined power from ten watts to forty watts. An external disable control and an onboard pulse width modulator provide flexibility in allowing either analog or PWM methods for dimming. The MC inverter can reliably dim to less than 0.5% duty cycle, which results in an electrical dimming ratio of greater than 200:1. Depending upon the attached backlight assembly, optical dimming ratios of greater than 1000:1 can be accomplished. Graph 1 shows the relationship of relative brightness to duty cycle for a typical backlight assembly.

External shutdown or external PWM operation of the inverter is accomplished using the Disable pin. Pulling this pin low (below V_{thoff}) disables the inverter. Enabling the inverter is accomplished by floating this pin or pulling this pin high (above V_{thon}). It should be noted that this pin is resistively coupled to the input voltage of the inverter (V_{in}), and therefore may have to be buffered to interface TTL logic.

If analog voltage dimming is required, the onboard PWM is enabled by connecting the PWMOut pin to the Disable pin. The analog voltage is applied to the Control pin. Figure 1 shows how to connect the inverter for onboard PWM operation. Graph 2 shows the relationship of PWM duty cycle to input control voltage.

If more than one inverter is used in a backlight assembly, the PWM signal for each inverter should be synchronized to prevent flickering. If an external PWM is used, simply connect the Disable pin of each inverter to the PWM source. If the onboard PWM is used, connect the analog voltage to the Control pin of one inverter. Connect the PWMOut signal of the inverter with the applied analog voltage to the Disable pin of all of the inverters, including the one with the applied analog voltage. This will utilize the PWM on only one inverter and will slave all of the other inverters.

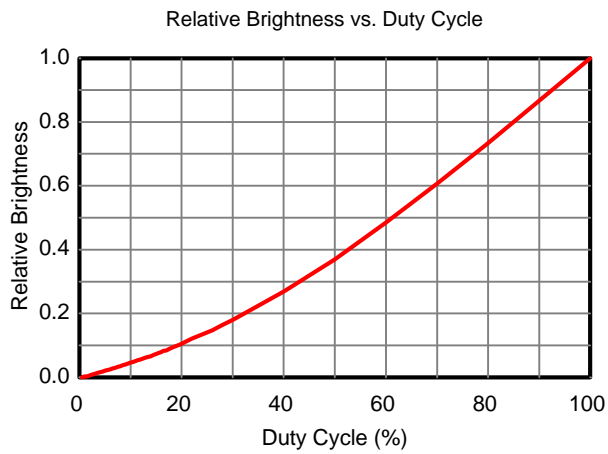

Graph 1

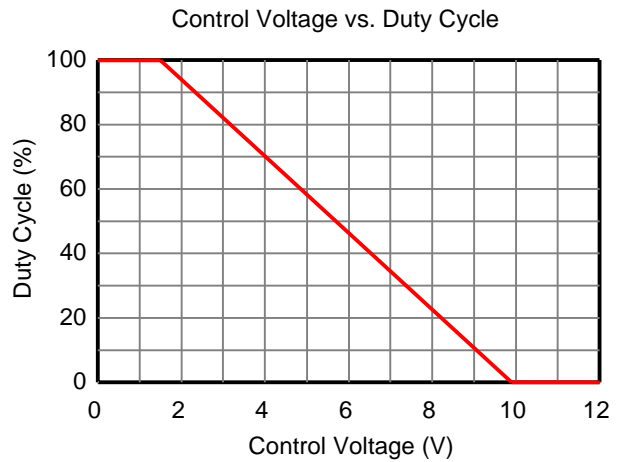

Graph 2

Typical Application

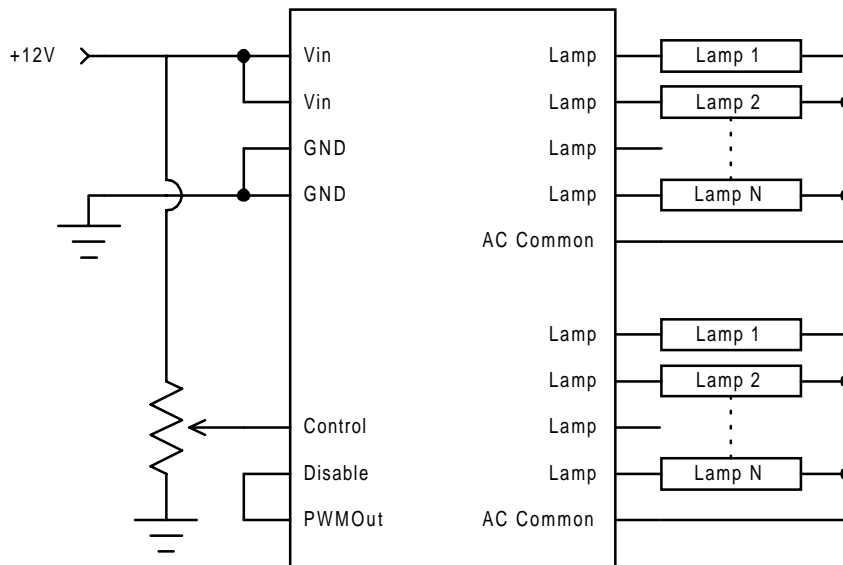

Figure 1



Endicott Research Group, Inc. (ERG) reserves the right to make changes in circuit design and/or specifications at any time without notice. Accordingly, the reader is cautioned to verify that data sheets are current before placing orders. Information furnished by ERG is believed to be accurate and reliable. However, no responsibility is assumed by ERG for its use.