



Endicott Research Group, Inc.

2601 Wayne St., Endicott, NY 13760
 607-754-9187 Fax 607-754-9255
<http://www.ergpower.com>

Specifications and Applications Information

04/23/04

Preliminary

The ERG LD3092 (LD Series) DC to AC inverter features onboard connectors and can be easily dimmed using an external analog control signal or an external PWM generator.

Powered by a regulated 12 Volt DC source, the LD3092 is designed to power the backlight of the LG Philips LM150X08-A4.

Product Features

- ✓ Small Package Size, less than 9mm in height.
- ✓ High Dimming Ratio
- ✓ High Efficiency
- ✓ Made in U.S.A.

This unit complements our L Series of DC to AC Inverters

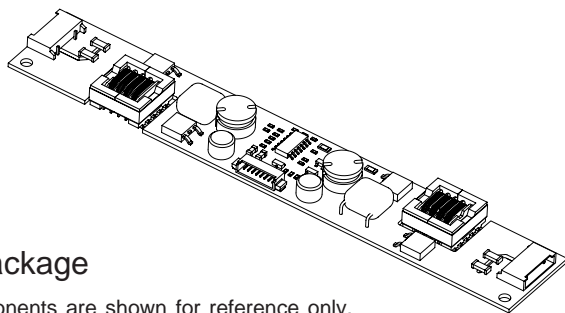

LD Package

PCB components are shown for reference only. Actual product may differ from that shown.

Connectors

J1,J3	J2
JST SM02(8.0)B-BHS-1-TB	Molex 53261-0890

LD3092

Two Tube DC to AC Inverter

Package Configuration

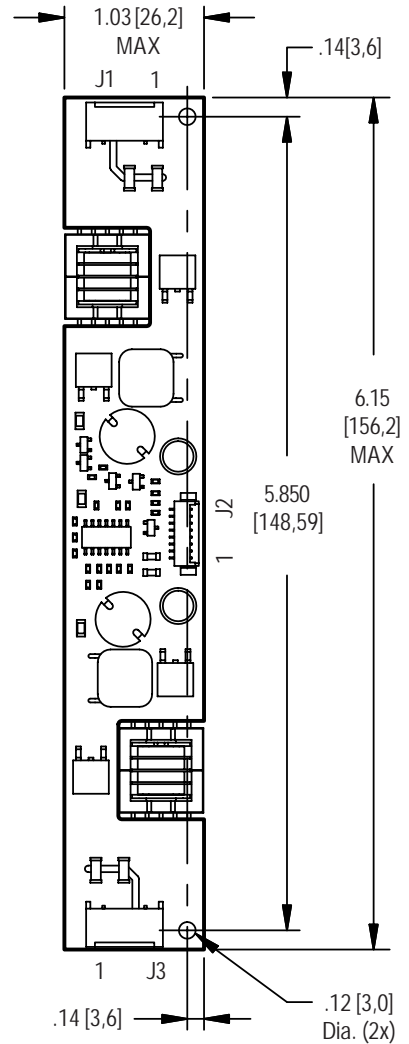

PCB components are shown for reference only. Actual product may differ from that shown.

Mass: 26 grams

Pin Descriptions

J1-1 ACout	J2-1 Vin	J3-1 ACout
J1-2 ACcommon	J2-2 Vin	J3-2 ACcommon
	J2-3 GND	
	J2-4 GND	
	J2-5 Enable	
	J2-6 Control	
	J2-7 N/C	
	J2-8 N/C	



Absolute Maximum Ratings (Note 1)

Rating	Symbol	Value	Units
Input Voltage	V_{in}	-0.3 to +13.2	Vdc
Enable	V_{Enable}	-0.3 to +0.3	Vdc
Operating Temperature	T_a	-0 to +85	°C
Storage Temperature	T_s	-40 to +85	°C

Recommended Operating Conditions

Rating	Symbol	Value	Units
Input Voltage	V_{in}	+10.8 to 12.6	Vdc
Operating Temperature <small>(Note 2)</small>	T_a	0 to +50	°C

Electrical Characteristics

Unless otherwise noted $V_{in} = 12.00$ Volts dc and $T_a = 25^\circ\text{C}$ and unit has been running for 20 minutes.

Characteristic	Symbol	Min	Typ	Max	Units
Input Current	I_{in}	-	.95	1.2	A _{DC}
Input Ripple Current	I_{rip}	-	100	-	mA _{pk-pk}
Operating Frequency	F_o	34	39	44	KHz
Efficiency	η	-	82	-	%
Output Voltage (no load)	V_{start}	1500	-	-	V
Output Voltage (with lamp)	V_{out}	-	585	-	V
Output Current (per tube)	I_{out}	-	8	-	mArms
Enable (pin J2-5)					
Turn-off Threshold	V_{thoff}	-	-	1	V
Turn-On Threshold	V_{thon}	2.5	-	V_{in}	V
Impedance to V_{in}	$R_{Disable}$	9.5	10.0	10.5	Kohm

(Note 1) Reliable and predictable operation of the device is not guaranteed with applied stresses at or beyond those listed in "Absolute Maximum Ratings". Operation at these limits may reduce device reliability and is therefore not recommended. Please refer to "Recommended Operating Conditions" for reliable operation of the device.

(Note 2) Reliable operation above 50°C is possible if airflow is provided.

Input voltage specification modified for clarity 4/2004.



Onboard PWM

Unless otherwise noted $V_{in} = 12.00$ Volts DC , $T_a = 25$ °C and unit has been running for 5 minutes.

Characteristic	Symbol	Min	Typ	Max	Units
Frequency	f_{pwm}	-	160	-	Hz
Control Input Bias Current	I_{cbias}	-	-	10	uA

Pin Descriptions

- Vin** Input voltage to the inverter. The two pins should be connected for optimum reliability and efficiency.
- GND** Inverter ground. The two pins should be connected for optimum reliability and efficiency.
- Control** Analog voltage input to the onboard pulse width modulator. Increasing this voltage increases the OFF time of the onboard PWM resulting in decreased brightness. The inverter is full ON when this voltage is near inverter ground.
- Enable** Inverter Enable. Pull this pin low to disable inverter operation. This pin must be high to enable the inverter. The onboard PWM is always utilized.

Application information

The LD series of inverters is designed to power up to four cold cathode fluorescent tubes with combined power from twelve watts. An external analog control interfaces with an onboard pulse width modulator to provide dimming control. The LD inverter can reliably dim to less than 5% duty cycle.

External shutdown of the inverter is accomplished using the Enable pin. Pulling this pin low (below V_{thoff}) disables the inverter. Enabling the inverter is accomplished by pulling this pin high (above V_{thon}).

If analog voltage dimming is required, the analog voltage is applied to the Control pin. Figure 1 shows how to connect the inverter for onboard PWM operation. Graph 1 shows the relationship of PWM duty cycle to input control voltage.

If an external PWM is used, simply connect the Enable pin to the PWM source and connect the Control pin to inverter GROUND. If the onboard PWM is used, connect the analog voltage to the Control pin.

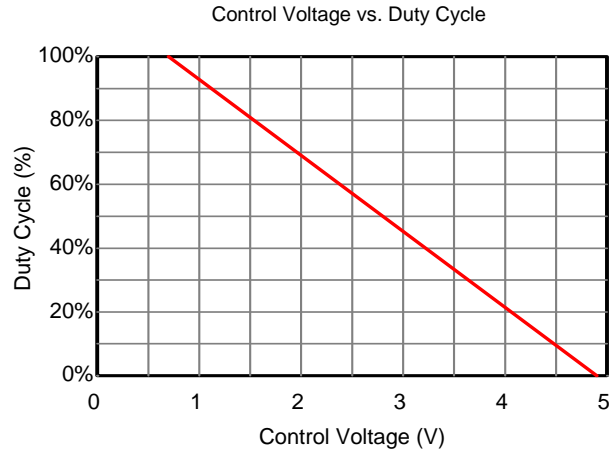

Graph 1

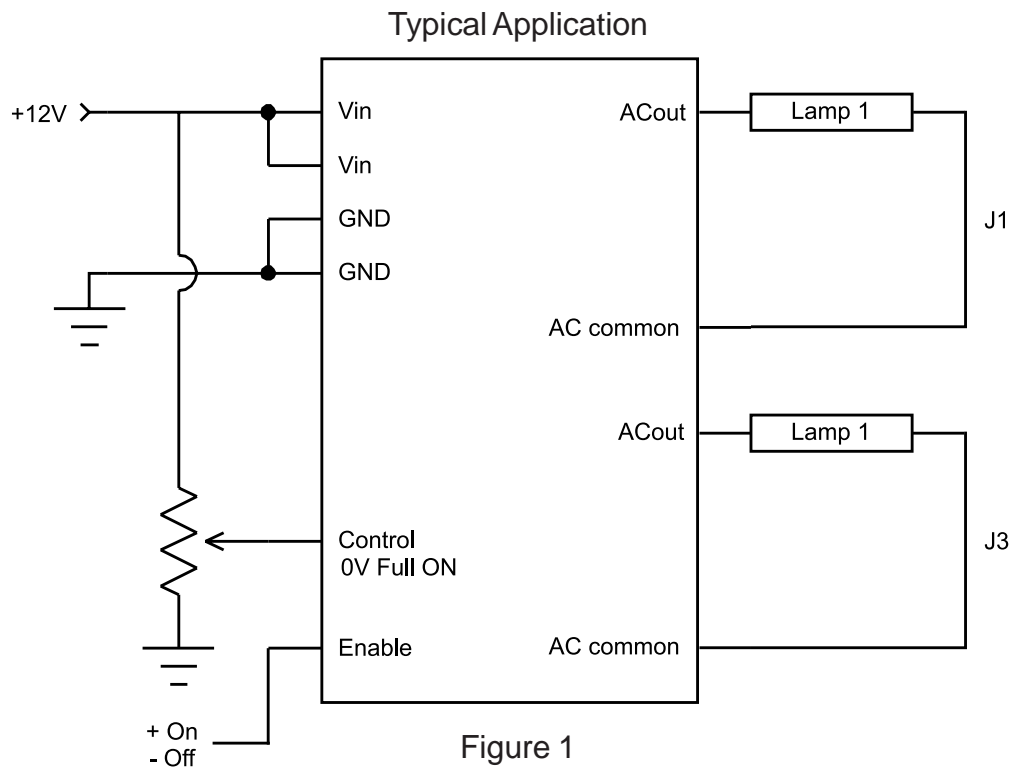

Figure 1



Endicott Research Group, Inc. (ERG) reserves the right to make changes in circuit design and/or specifications at any time without notice. Accordingly, the reader is cautioned to verify that data sheets are current before placing orders. Information furnished by ERG is believed to be accurate and reliable. However, no responsibility is assumed by ERG for its use.