



# Endicott Research Group, Inc.

2601 Wayne St., Endicott, NY 13760  
 607-754-9187 Fax 607-754-9255  
<http://www.ergpower.com>

## Specifications and Applications Information

04/05/11

The ERG LD2882 (LD Series) DC to AC inverter features onboard connectors and can be easily dimmed using an external analog control signal or an external PWM generator.

Powered by a regulated +12 Volt DC source, the LD2882 is designed to power the Sharp LQ150X1DG11 and LQ150X1DG16 display backlights.

### Product Features

- ✓ Small Package Size, less than 9mm in height
- ✓ High Dimming Ratio
- ✓ High Efficiency
- ✓ Made in U.S.A.

This unit complements our L Series of DC to AC Inverters

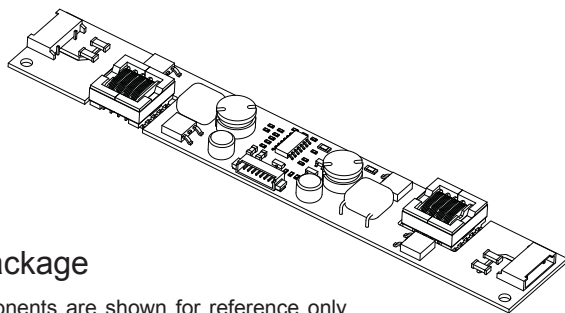

### LD Package

PCB components are shown for reference only. Actual product may differ from that shown.

### Connectors

J1, J3  
 JST  
 SM02(8.0)B-BHS-1-TB

J2  
 Molex  
 53261-0871

# LD2882

## Two Lamp DC to AC Inverter

### Package Configuration

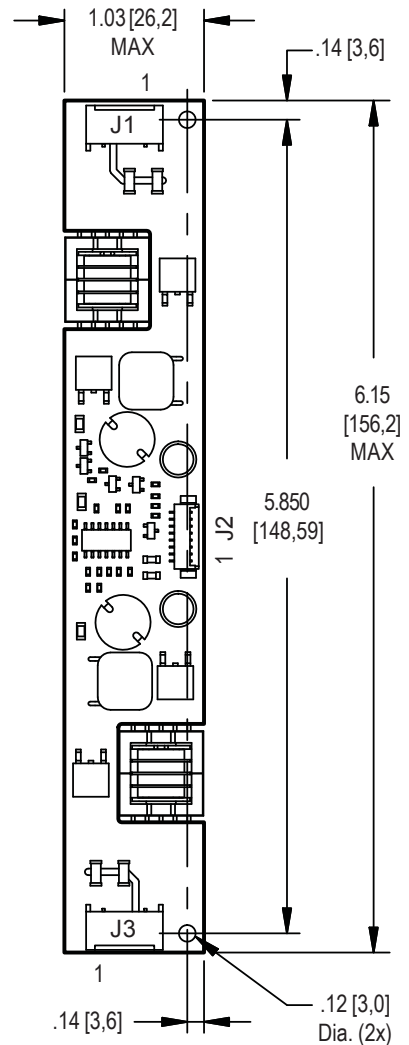

PCB components are shown for reference only. Actual product may differ from that shown.

Mass: 26 grams

### Pin Descriptions

J1-1 ACout	J2-1 +Vin	J3-1 ACout
J1-2 ACreturn	J2-2 +Vin	J3-2 ACreturn
	J2-3 GND	
	J2-4 GND	
	J2-5 Enable	
	J2-6 Control	
	J2-7 N/C	
	J2-8 N/C	

**Absolute Maximum Ratings**

Rating	Symbol	Value	Units
Input Voltage Range	$V_{in}$	-0.3 to +13.2	Vdc
Storage Temperature	$T_{stg}$	-40 to +85	°C

**Operating Characteristics**

With a load simulating the referenced display and lamp warm-up of 5 minutes.  
Unless otherwise noted  $V_{in} = 12.00$  Volts dc and  $T_a = 25^{\circ}\text{C}$ .

Characteristic	Symbol	Min	Typ	Max	Units
Input Voltage	$V_{in}$	+10.8	+12.0	+12.6	Vdc
Component Surface Temperature (note 1)	$T_s$	-20	-	+80	°C
Input Current (note 2)	$I_{in}$	-	0.45	0.52	Adc
Input Ripple Current	$I_{rip}$	-	20	-	mA <sub>pk-pk</sub>
Operating Frequency	$F_o$	33	38	43	kHz
Minimum Output Voltage (note 3)	$V_{out}(\text{min})$	1500	-	-	Vrms
Efficiency	$\eta$	-	74	-	%
Output Current (per lamp)	$I_{out}$	-	6.0	-	mArms
Output Voltage	$V_{out}$	-	670	-	Vrms

**Enable Pin**

Turn-off Threshold	$V_{thoff}$	GND	-	0.5	Vdc
Turn-on Threshold	$V_{thon}$	2.5	-	$V_{in}$	Vdc
Impedance to $V_{in}$	$R_{Enable}$	-	10	-	kOhms

Specifications subject to change without notice.

(Note 1) Surface temperature must not exceed 80 degrees C; thermal management actions may be required.

(Note 2) Input current in excess of maximum may indicate a load/inverter mismatch condition, which can result in reduced reliability. Please contact ERG technical support.

(Note 3) Provided data is not tested but guaranteed by design.

**Application Notes:**

- 1) The minimum distance from high voltage areas of the inverter to any conductive material should be .12 inches per kilovolt of starting voltage.
- 2) Mounting hardware to be non-conductive.
- 3) Open framed inverters should not be used in applications at altitudes over 10,000 feet.
- 4) ACreturn must be left floating, not grounded.
- 5) Contact ERG for possible exceptions.



## Onboard PWM

Unless otherwise noted  $V_{in} = 12.00$  Volts DC,  $T_a = 25$  °C and unit has been running for 5 minutes.

Characteristic	Symbol	Min	Typ	Max	Units
Frequency	$f_{pwm}$	-	160	-	Hz
Control Input Bias Current	$I_{cbias}$	-	-	10	$\mu A$

## Pin Descriptions

- +Vin** Input voltage to the inverter. The two pins should be connected for optimum reliability and efficiency.
- GND** Inverter ground. The two pins should be connected for optimum reliability and efficiency.
- Control** Analog voltage input to the onboard pulse width modulator. Increasing this voltage increases the OFF time of the onboard PWM resulting in decreased brightness. The inverter is full ON when this voltage is near inverter ground.
- Enable** Inverter Enable. Pull this pin low to disable inverter operation. This pin must be high to enable the inverter. The onboard PWM is always utilized.

## Application information

The LD series of inverters is designed to power up to four cold cathode fluorescent lamps with combined power from twelve watts. An external analog control interfaces with an onboard pulse width modulator to provide dimming control. The LD inverter can reliably dim to less than 5% duty cycle.

External shutdown of the inverter is accomplished using the Enable pin. Pulling this pin low (below  $V_{thoff}$ ) disables the inverter. Enabling the inverter is accomplished by pulling this pin high (above  $V_{thon}$ ).

If analog voltage dimming is required, the analog voltage is applied to the Control pin. Figure 1 shows how to connect the inverter for onboard PWM operation. Graph 1 shows the relationship of PWM duty cycle to input control voltage.

If an external PWM is used, simply connect the Enable pin to the PWM source and connect the Control pin to inverter ground. If the onboard PWM is used, connect the analog voltage to the Control pin.

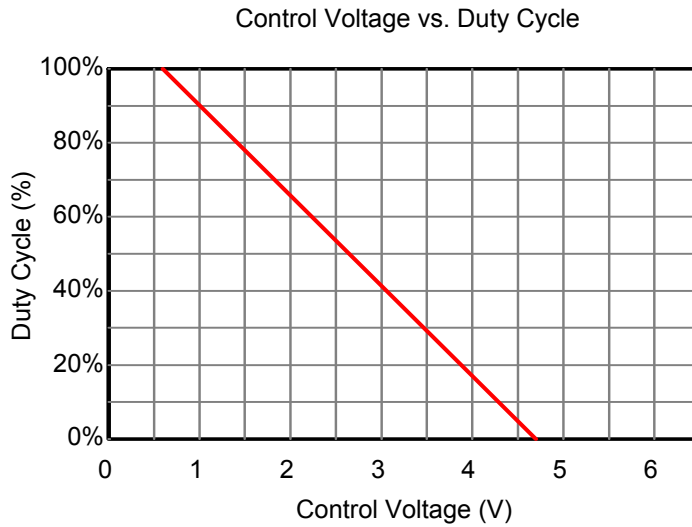

Graph 1

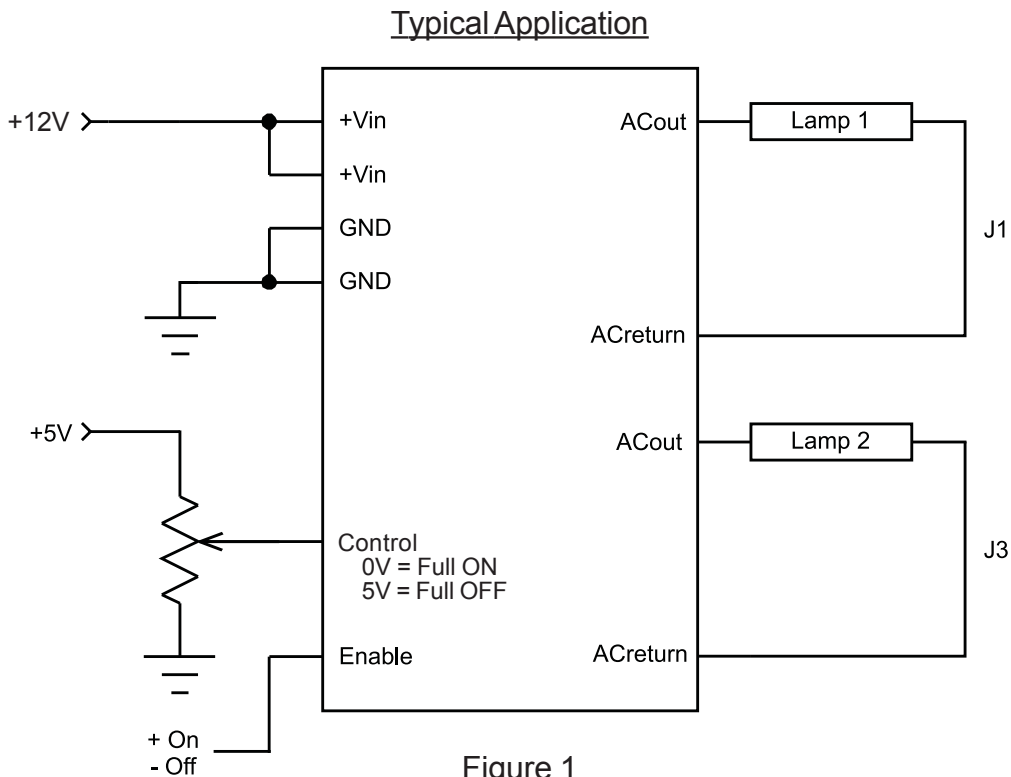

Figure 1



Endicott Research Group, Inc. (ERG) reserves the right to make changes in circuit design and/or specifications at any time without notice. Accordingly, the reader is cautioned to verify that data sheets are current before placing orders. Information furnished by ERG is believed to be accurate and reliable. However, no responsibility is assumed by ERG for its use.