

L2373

Dimming Option

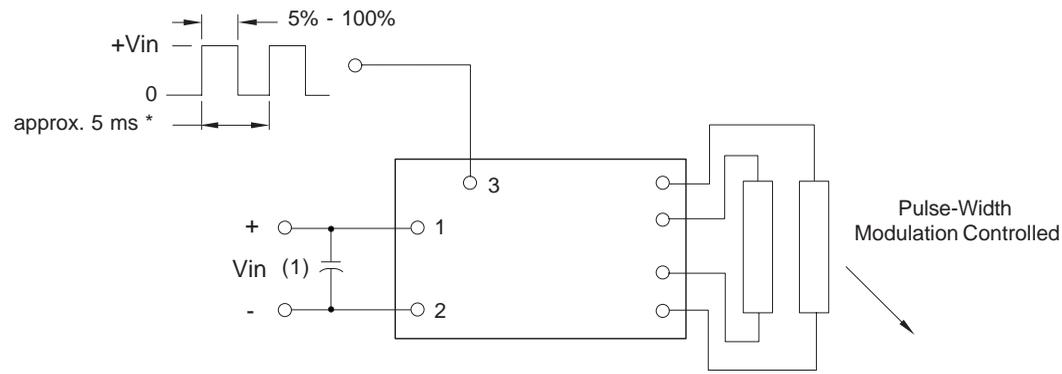

* should be selected to be compatible with LCD and display driver.

Note 1 Input by-pass capacitor (25uf - 100uf) may be required to reduce reflected ripple.



Endicott Research Group, Inc.
 2601 Wayne St., Endicott NY 13760
 607-754-9187



Endicott Research Group, Inc.
 2601 Wayne St., Endicott NY 13760
 607-754-9187 Fax 607-754-9255
<http://www.ergpower.com>

L2373

8m Class DC to AC Inverter

Specifications and Applications Information

02/04/02

Preliminary

The ERG L2373 (8m Class) low profile dc to ac inverter is specifically designed to power the Mitsubishi AA104VB04 LCD display module to a moderate brightness level from a +5 volt dc source.

This low profile inverter features:

- ✓ Less Than 8 mm in Height
- ✓ LCD Module Specific
- ✓ Display Compatible Output Connector
- ✓ Firm Specifications
- ✓ Application Information
- ✓ Designed, Manufactured and Supported in the USA
- ✓ Custom Input and Output Voltages
- ✓ Flexible System Interface

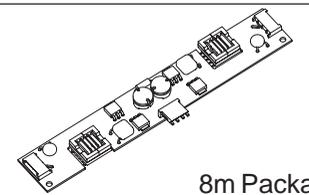

8m Package

Package Configuration

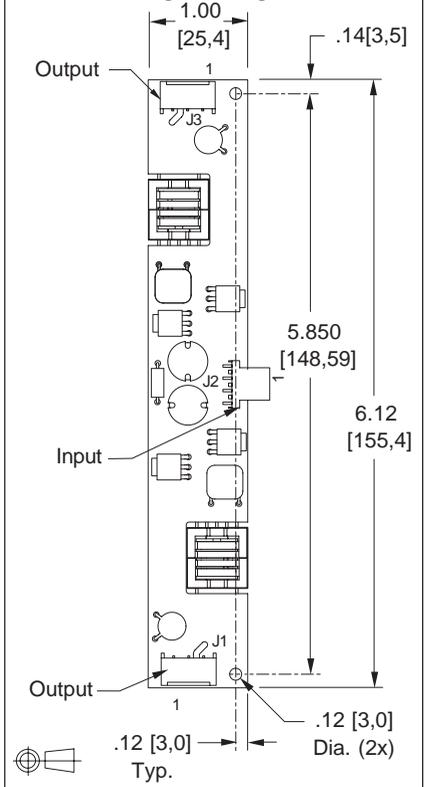

Pin Descriptions

Input Connector		Output Connectors	
MOLEX 22-05-3041		JST SM02(8.0)B-BHS1TB	
J2-1	Vin	J1-1	ACout
J2-2	GND	J1-2	N/C
J2-3	Control	J1-3	ACcommon
J2-4	N/C	J3-1	ACout
		J3-2	N/C
		J3-3	ACcommon

L2373

Absolute Maximum Ratings

Rating	Symbol	Value	Units
Input Voltage Range	V _{in}	-0.3 to +5.5	Vdc
Operating Temperature	T _o	0 to +70	°C
Storage Temperature	T _{stg}	-40 to +85	°C

Recommended Operating Conditions

Rating	Symbol	Value	Units
Input Voltage	V _{in}	+2.5 to 5.5	Vdc

Electrical Characteristics

Unless otherwise noted V_{in} = 5.00 Volts dc and T_a = 25 °C

Characteristic	Symbol	Min	Typ	Max	Units
Input Current	I _{in}	-	1.8	2.1	Adc
Operating Frequency	F _o	35	40	45	KHz
Minimum Output Voltage	V _{out} (min)	1400	-	-	Vrms
Efficiency	η	-	84	-	%
Output Current per tube	I _{out}	-	6.5	-	marms
Output Voltage (when Powering a load simulating the referenced display)	V _{out}	-	580	-	Vrms
Pin3 Input Current Requirement	-	-	26	-	madc

After tube has been allowed to warm-up for 5 minutes
External Disable Circuit shown on page 3.

Specifications subject to change without notice.



Endicott Research Group, Inc.

Typical Performance Curves

L2373

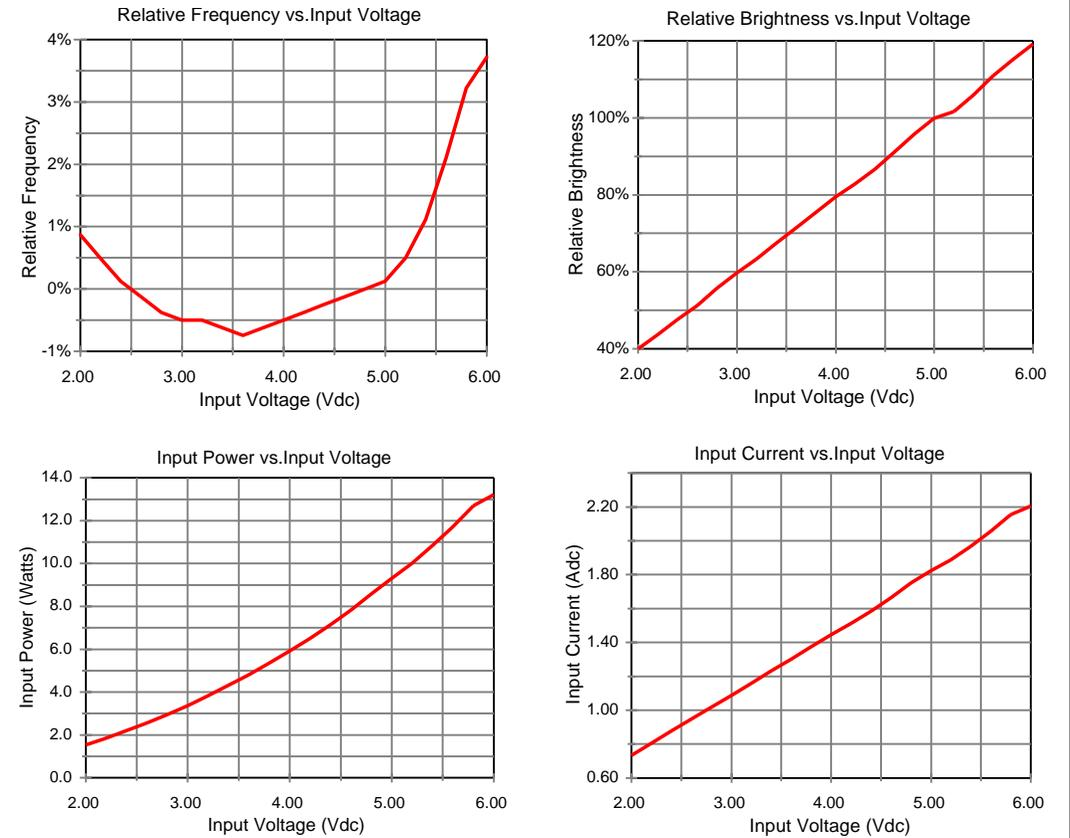

Disable Circuit

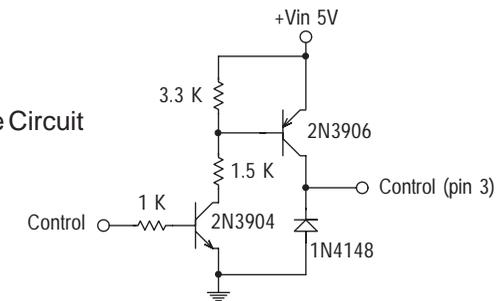

Endicott Research Group, Inc.