



Endicott Research Group, Inc.

2601 Wayne St., Endicott, NY 13760
 607-754-9187 Fax 607-754-9255
<http://www.ergpower.com>

K3230

Specifications and Applications Information

09/28/06 Preliminary

8m Class 2 Lamp DC to AC Inverter

The ERG K3230 (*8m Class*) low profile dc to ac inverter is specifically designed to power the Optrex T-51750GD065J-FW-AA LCD display module to a moderate brightness level from a +12 volt dc source.

This low profile inverter features:

- ✓ Less Than 8 mm in Height
- ✓ LCD Module Specific
- ✓ Display Compatible Output Connector
- ✓ Firm Specifications
- ✓ Application Information
- ✓ Designed, Manufactured and Supported in the USA
- ✓ Custom Input and Output Voltages
- ✓ Flexible System Interface
- ✓ Notebook Display Head Compatible

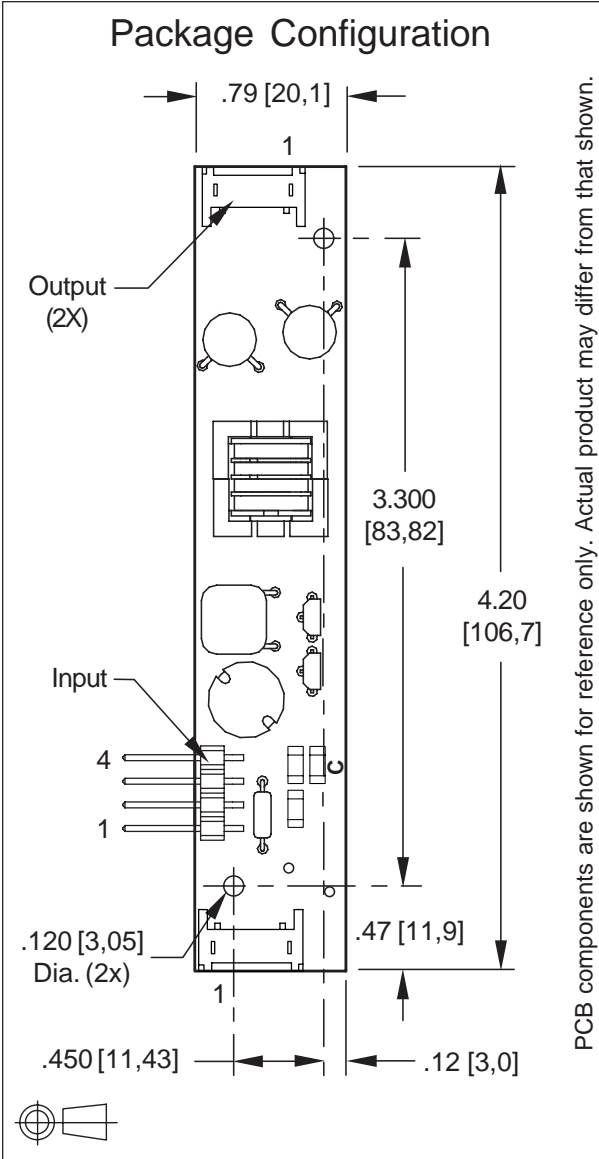
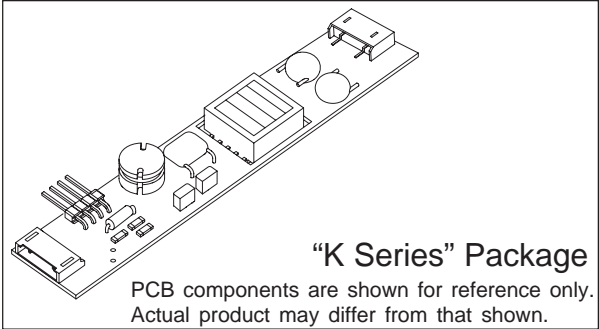

Connectors	
Input Connector	Output Connectors
4 pins are 0.315" [8,00] Long, 0.025" [0,63] Square and are on 0.100" [2,54] Centers.	JST SM02(8.0)B-BHS-1-TB
J1-1 Vin(+) J1-2 GND J1-3 Enable * J1-4 N/C	J2-1 ACout J3-1 ACout J2-2 ACout J3-2 ACout
* Valid with the "C" Jumper removed	

Absolute Maximum Ratings

Rating	Symbol	Value	Units
Input Voltage Range	Vin	-0.3 to +13.2	Vdc
Storage Temperature	Tstg	-40 to +85	°C

Operating Characteristics

With the referenced display and lamp warm-up of 5 minutes.
Unless otherwise noted Vin = 12.00 Volts dc and Ta = 25°C.

Characteristic	Symbol	Min	Typ	Max	Units
Input Voltage	Vin	+10.8	+12.0	+12.6	Vdc
Component Surface Temperature	Ts	-20	-	+80	°C
Input Current (note 1)	Iin	-	0.40	0.45	Adc
Operating Frequency	Fo	41	46	51	kHz
Minimum Output Voltage	Vout (min)	1000	-	-	Vrms
Efficiency	η	-	81	-	%
Output Current (per lamp)	Iout	-	6.1	-	mArms
Output Voltage	Vout	-	320	-	Vrms
Enable Pin Input Current Requirement (note 2)	Ien	-	4.4	-	mAdc

Specifications subject to change without notice.

(Note 1) Input current in excess of maximum may indicate a load/inverter mismatch condition, which can result in reduced reliability. Please contact ERG technical support.

(Note 2) Valid only with the "C" jumper removed.

Application Notes:

- 1) The minimum distance from high voltage areas of the inverter to any conductive material should be .12 inches per kilovolt of starting voltage.
- 2) Mounting hardware should be non-conductive.
- 3) Open framed inverters should not be used in applications at altitudes over 10,000 feet.
- 4) Contact ERG for possible exceptions.



Endicott Research Group, Inc.

2601 Wayne St., Endicott, NY 13760
607-754-9187 Fax 607-754-9255
<http://www.ergpower.com>

Made in USA



PWM Dimming

(Valid only with the "C" Jumper removed)

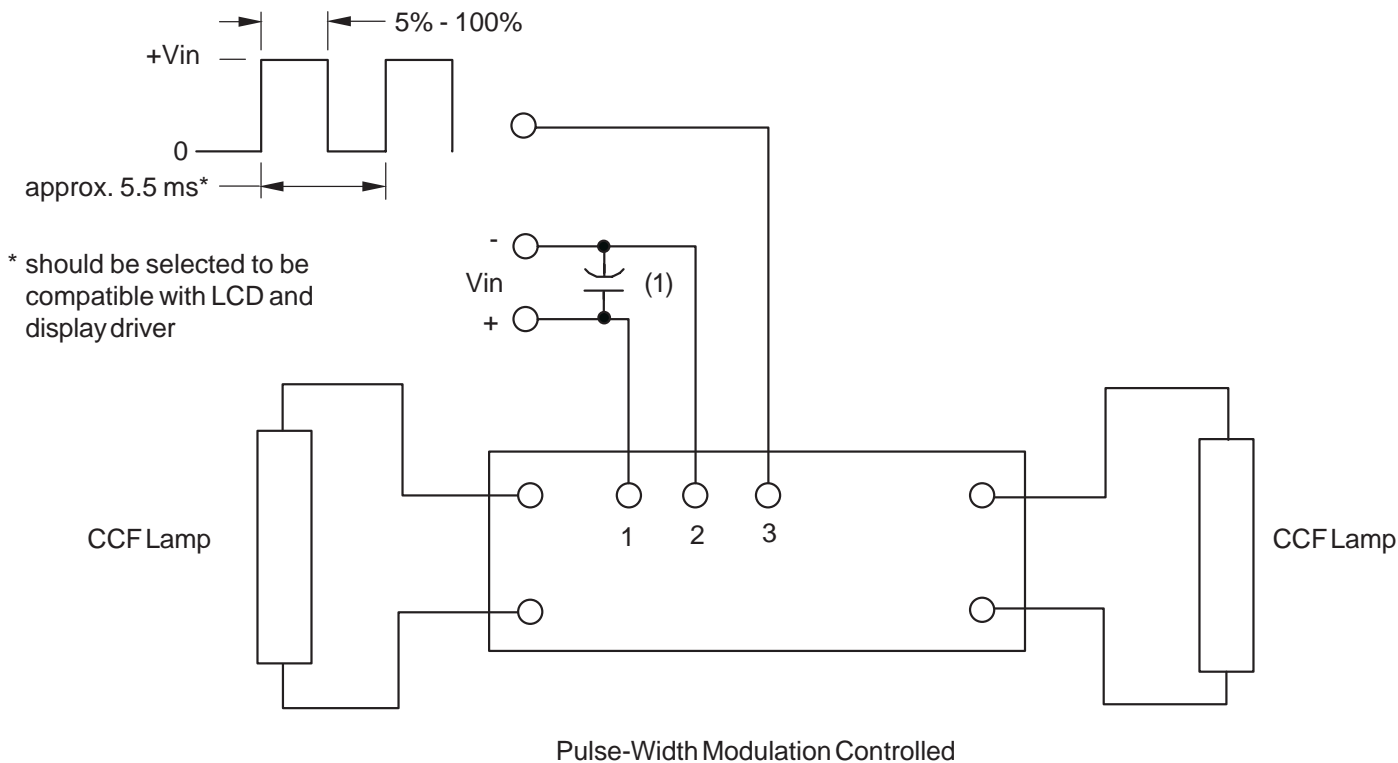

Note 1 - Low ESR type input by-pass capacitor (22 uf - 100 uf) may be required to reduce reflected ripple.

Recommended User Disable/Interface Circuit

Circuit or equivalent required with "C" jumper removed for proper inverter turnoff.

0-0.5V Inverter OFF
2.0V - 12V Inverter ON

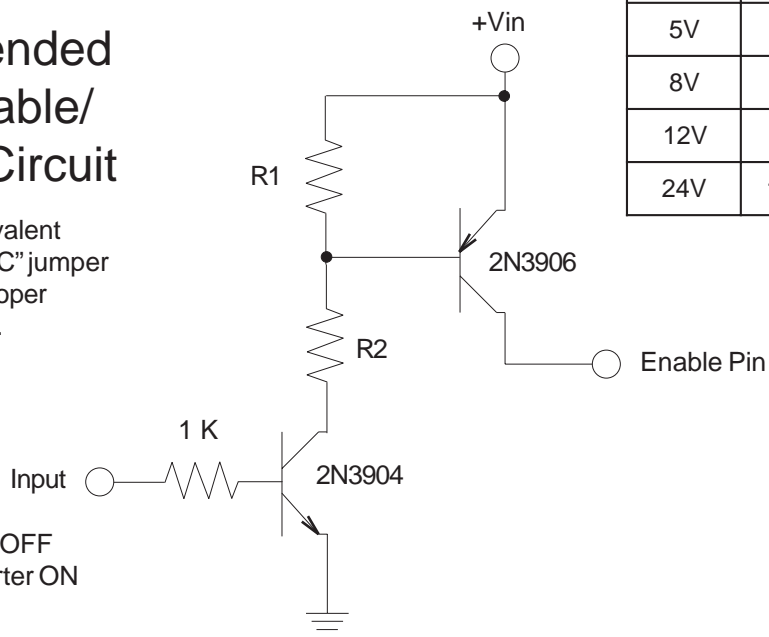

Vin	R1	R2
5V	3.3K	1.5K
8V	3.3K	1.8K
12V	3.3K	2.2K
24V	10.0K	8.2K



Endicott Research Group, Inc. (ERG) reserves the right to make changes in circuit design and/or specifications at any time without notice. Accordingly, the reader is cautioned to verify that data sheets are current before placing orders. Information furnished by ERG is believed to be accurate and reliable. However, no responsibility is assumed by ERG for its use.