



Endicott Research Group, Inc.

2601 Wayne St., Endicott, NY 13760
 607-754-9187 Fax 607-754-9255
<http://www.ergpower.com>

K2766

Specifications and Applications Information

11/18/09 Preliminary

8m Class 2 Lamp DC to AC Inverter

The ERG K2766 (*8m Class*) low profile dc to ac inverter is specifically designed to power the NEC NL6448BC26-01 LCD display module to a moderate brightness level from a +12 volt dc source.

This low profile inverter features:

- ✓ Less Than 8 mm in Height
- ✓ LCD Module Specific
- ✓ Display Compatible Output Connector
- ✓ Firm Specifications
- ✓ Application Information
- ✓ Designed, Manufactured and Supported in the USA
- ✓ Custom Input and Output Voltages
- ✓ Flexible System Interface
- ✓ Notebook Display Head Compatible

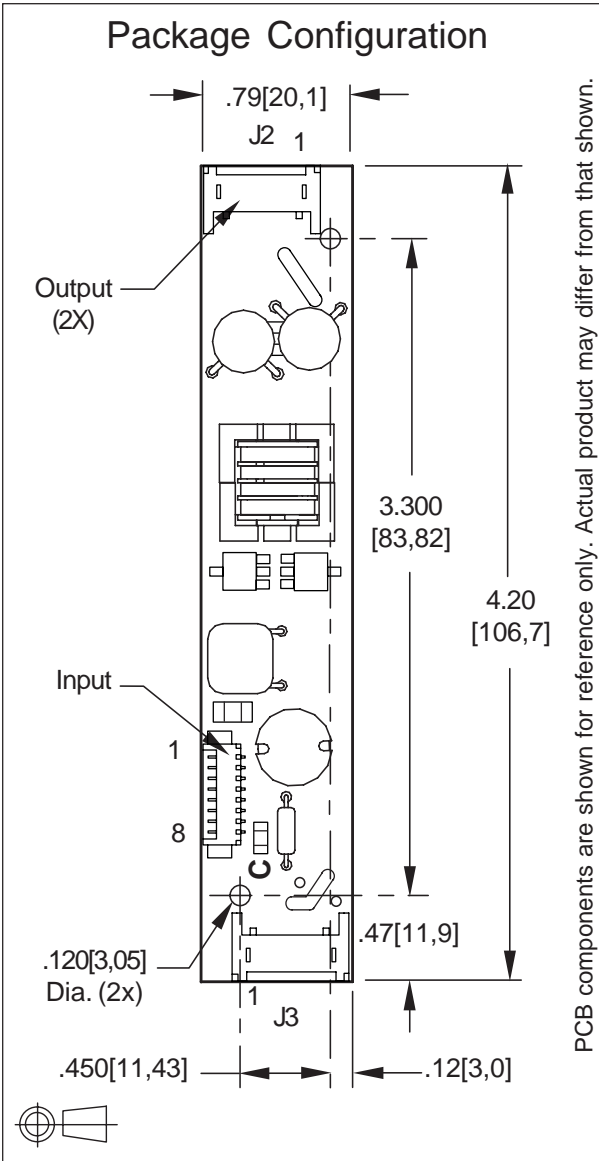
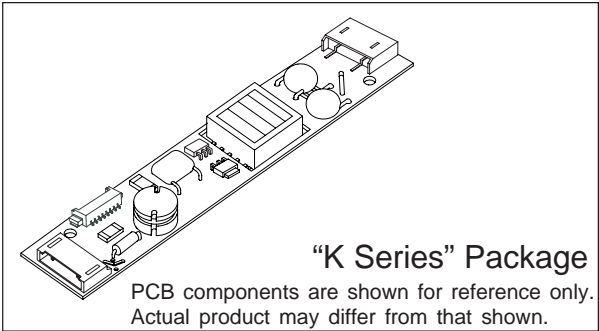

Connectors	
Input Connector	Output Connectors
Molex 53261-0871	JST SM02(8.0)B-BHS-1-TB
J1-1 +Vin J1-2 +Vin J1-3 GND J1-4 GND J1-5 Enable/PWM * J1-6 N/C J1-7 N/C J1-8 N/C	J2-1 ACout J2-2 ACreturn J3-1 ACout J3-2 ACreturn
* Valid only with "C" jumper (JP1) removed	

Absolute Maximum Ratings

Rating	Symbol	Value	Units
Input Voltage Range	V_{in}	-0.3 to +13.2	Vdc
Storage Temperature	T_{stg}	-40 to +85	°C

Operating Characteristics

With a load simulating the referenced display and lamp warm-up of 5 minutes.
Unless otherwise noted $V_{in} = 12.00$ Volts dc and $T_a = 25^{\circ}\text{C}$.

Characteristic	Symbol	Min	Typ	Max	Units
Input Voltage	V_{in}	+10.8	+12.0	+12.6	Vdc
Component Surface Temperature ^(note 1)	T_s	-20	-	+80	°C
Input Current ^(note 2)	I_{in}	-	0.45	0.52	Adc
Operating Frequency	F_o	37	42	47	kHz
Minimum Output Voltage ^(note 3)	$V_{out} \text{ (min)}$	1200	-	-	Vrms
Efficiency	η	-	82	-	%
Output Current (per lamp)	I_{out}	-	5.0	-	mArms
Output Voltage	V_{out}	-	440	-	Vrms
Enable Pin Input Current Requirement ^(notes 4,5,6)	I_{Enable}	-	5.5	-	mAdc

Specifications subject to change without notice.

(Note 1) Surface temperature must not exceed 80 degrees C; thermal management actions may be required.

(Note 2) Input current in excess of maximum may indicate a load/inverter mismatch condition, which can result in reduced reliability. Please contact ERG technical support.

(Note 3) Provided data is not tested but guaranteed by design.

(Note 4) Required User Enable/Disable Interface Circuit is shown on page 3.

(Note 5) Valid only with "C" jumper (JP1) removed.

(Note 6) With the inverter powered and JP1 is in place, a ground applied to the enable pin J1-5 will open the inverter fuse.

Application Notes:

- 1) The minimum distance from high voltage areas of the inverter to any conductive material should be .12 inches per kilovolt of starting voltage.
- 2) Mounting hardware to be non-conductive.
- 3) Open framed inverters should not be used in applications at altitudes over 10,000 feet.
- 4) ACreturn should be left floating, not grounded.
- 5) Contact ERG for possible exceptions.



Endicott Research Group, Inc.

2601 Wayne St., Endicott, NY 13760
607-754-9187 Fax 607-754-9255
<http://www.ergpower.com>

Made in USA

PWM Dimming

(Valid only with JP1 removed)

Required User Enable/Disable Interface Circuit

With JP1 in place, a ground applied to the enable pin J1-5 will open the inverter fuse.

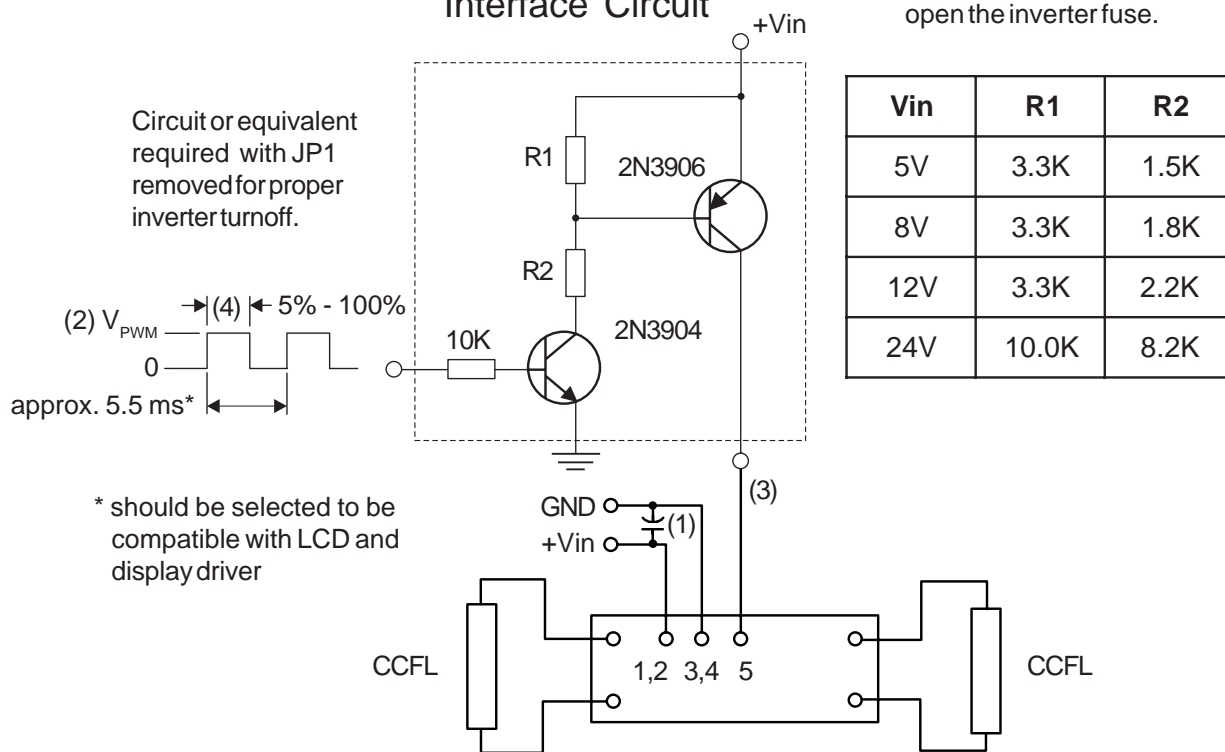

- (1) Low ESR type input by-pass capacitor (22 uF - 100 uF) may be required to reduce reflected ripple.
- (2) $V_{P_{PWM}}$ from 2.4V to less than or equal to +Vin.
- (3) Full brightness without PWM control requires that pin 5 be tied to +Vin. Pin 5 must be at 0V to turn off.
- (4) Duty Cycle 5% - 100%.