



# Endicott Research Group, Inc.

2601 Wayne St., Endicott, NY 13760  
 607-754-9187 Fax 607-754-9255  
<http://www.ergpower.com>

# E3255

## Specifications and Applications Information

11/08/05 Preliminary

The E3255 (E200II Series) dc to ac inverter is specifically designed to power the Kyocera TCG075VG2A display to a moderate brightness level from a +5 volt dc source.

The E3255's small size and encapsulated package makes it the ideal power source for applications where small size, high efficiency and reliability are critical.

This inverter is designed to satisfy the most common cold-cathode lighting requirements for the Kyocera TCG075VG2A display. Custom units, providing different inputs, outputs or package refinements are available.

## Two Lamp DC to AC Inverter

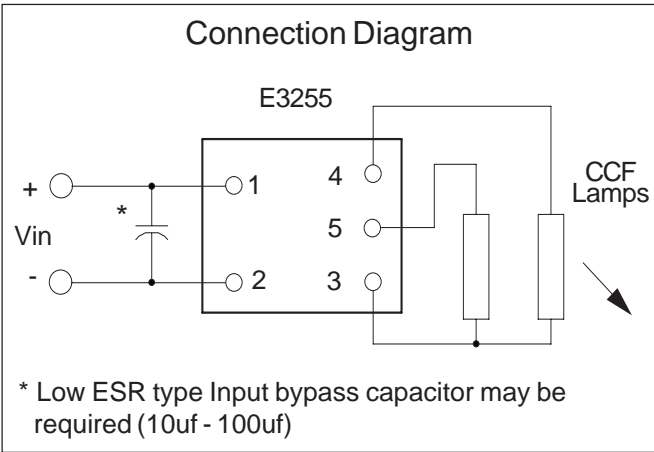
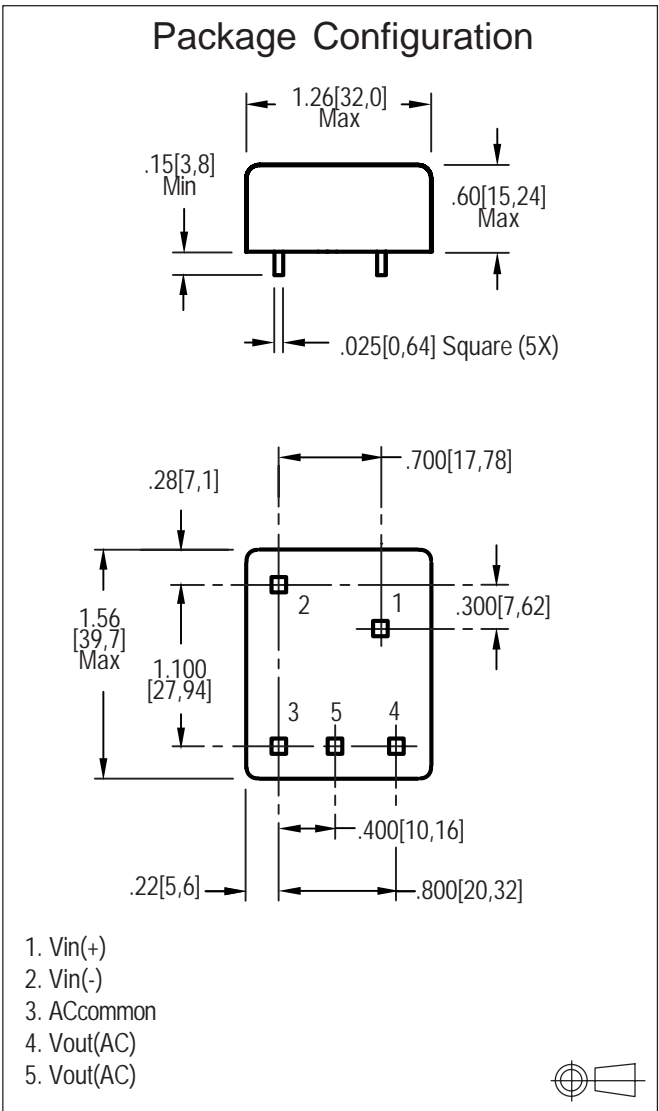
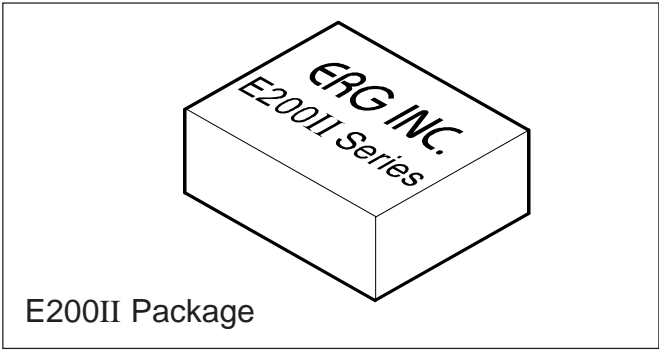

**Absolute Maximum Ratings**

Rating	Symbol	Value	Units
Input Voltage Range	Vin	-0.3 to +5.25	Vdc
Operating Temperature	To	-0 to +70	°C
Storage Temperature	Tstg	-40 to +85	°C

**Recommended Operating Conditions**

Rating	Symbol	Value	Units
Input Voltage	Vin	+4.50 to 5.25	Vdc

**Electrical Characteristics**

Unless otherwise noted Vin = 5.00 Volts dc and Ta = 25°C

Characteristic	Symbol	Min	Typ	Max	Units
Input Current	lin	-	.98	1.13	Adc
Operating Frequency	Fo	29	34	39	KHz
Minimum Output Voltage	Vout (min)	1500	-	-	Vrms
Efficiency	-	-	85	-	%
Output Current per CCFL	Iout	-	5.1	-	marms
Output Voltage (When powering a Load simulating the referenced display)	Vout	-	410	-	Vrms

After lamp has be allowed to warm-up for 5 minutes

Specifications subject to change without notice.

**Application Notes:**

- 1) Printed circuit boards should be free of traces beneath the inverter.
- 2) The minimum distance from high voltage areas of the inverter to any conductive material should be .12 inches per kilovolt of starting voltage.
- 3) Contact ERG for possible exceptions.



**Endicott Research Group, Inc.**

2601 Wayne St., Endicott, NY 13760  
607-754-9187 Fax 607-754-9255  
<http://www.ergpower.com>

Made in U.S.A.