



Endicott Research Group, Inc.

2601 Wayne St., Endicott, NY 13760

607-754-9187 Fax 607-754-9255

http://www.ergpower.com

E2639

Specifications and Applications Information

12/13/10

Single Lamp DC to AC Inverter

The E2639 (E200II Series) dc to ac inverter is specifically designed to power the Optrex DMF50036 LCD display to a moderate brightness level from a +12 volt dc source.

The E2639's small size, encapsulated package and low input power requirements make it the ideal power source for battery applications where small size, high efficiency and reliability are critical.

This inverter is designed to satisfy the most common cold-cathode lighting requirements for the DMF50036 display. Custom units, providing different inputs, outputs or package refinements are available.

Made in U.S.A.

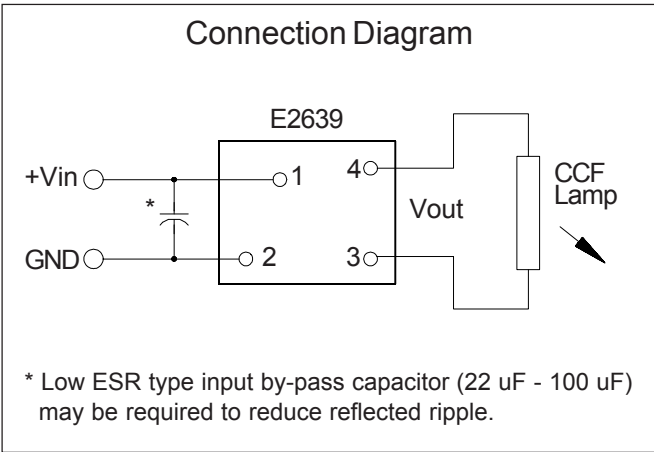
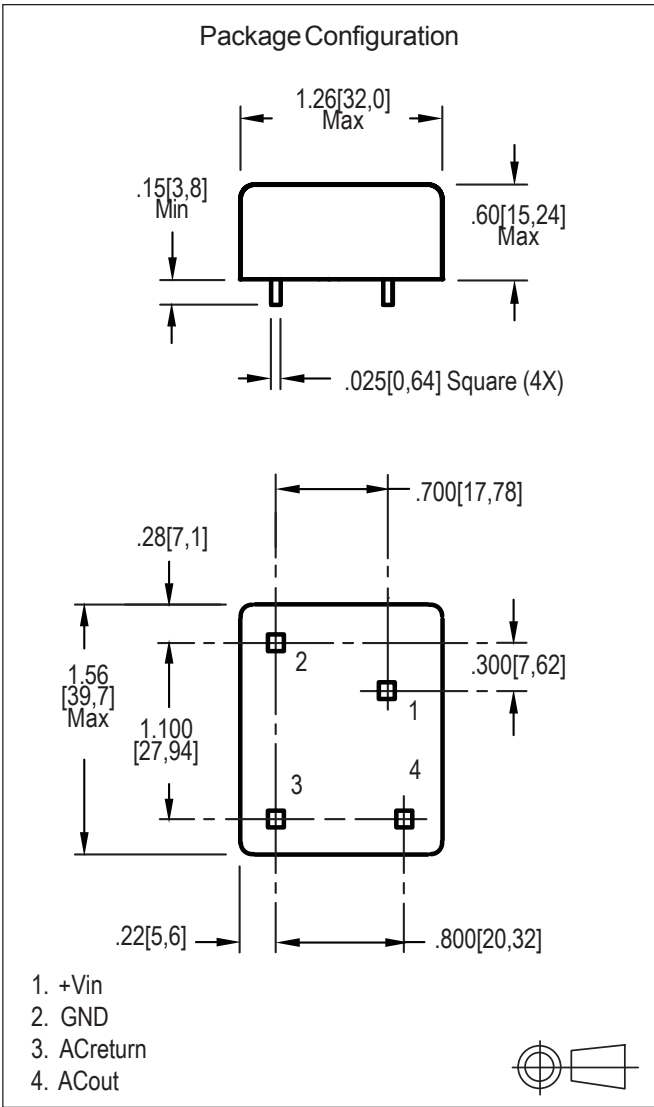
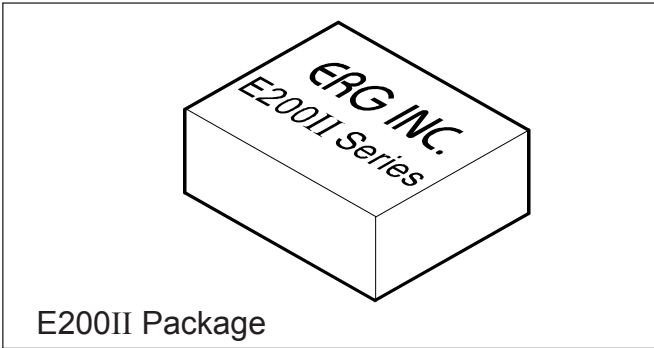



Absolute Maximum Ratings

Rating	Symbol	Value	Units
Input Voltage Range	V_{in}	-0.3 to +13.2	Vdc
Storage Temperature	T_{stg}	-40 to +85	°C

Operating Characteristics

With a load simulating the referenced display and lamp warm-up of 5 minutes.
 Unless otherwise noted $V_{in} = 12.00$ Volts dc and $T_a = 25^{\circ}C$.

Characteristic	Symbol	Min	Typ	Max	Units
Input Voltage	V_{in}	+10.8	+12.0	+12.6	Vdc
Component surface Temperature (note 1)	T_s	-20	-	+80	°C
Input Current (note 2)	I_{in}	-	0.21	0.25	Adc
Operating Frequency	F_o	25	30	40	kHz
Minimum Output Voltage (note 3)	$V_{out} (min)$	1100	-	-	Vrms
Efficiency	η	-	77	-	%
Output Current (per lamp)	I_{out}	-	5.0	-	mArms
Output Voltage	V_{out}	-	390	-	Vrms

Specifications subject to change without notice.

- (Note 1) Surface temperature must not exceed 80 degrees C; thermal management actions may be required.
- (Note 2) Input current in excess of maximum may indicate a load/inverter mismatch condition, which can result in reduced reliability. Please contact ERG technical support.
- (Note 3) Provided data is not tested but guaranteed by design.

Application Notes:

- 1) Printed circuit boards to be free of traces beneath the inverter.
- 2) The minimum distance from high voltage areas of the inverter to any conductive material should be .12 inches per kilovolt of starting voltage.
- 3) ACreturn should be left floating, not grounded.
- 4) Contact ERG for possible exceptions.



Endicott Research Group, Inc. (ERG) reserves the right to make changes in circuit design and/or specifications at any time without notice. Accordingly, the reader is cautioned to verify that data sheets are current before placing orders. Information furnished by ERG is believed to be accurate and reliable. However, no responsibility is assumed by ERG for its use.