E200II Series



Encapsulated Solution for Single or Dual Tube LCD Modules



- .60 inches High
- PCB Mountable
- Dimming Options Available
- High Efficiency
- Fully Encapsulated
- Up to 8 Watts of Output Power
- Designed, Manufactured and Supported in the USA
- One Year Warranty



Endicott Research Group, Inc.

2601 Wayne St., Endicott, NY 13760

607-754-9187 Fax 607-754-9255

<http://www.ergpower.com>



E200II Series



Product Configuration

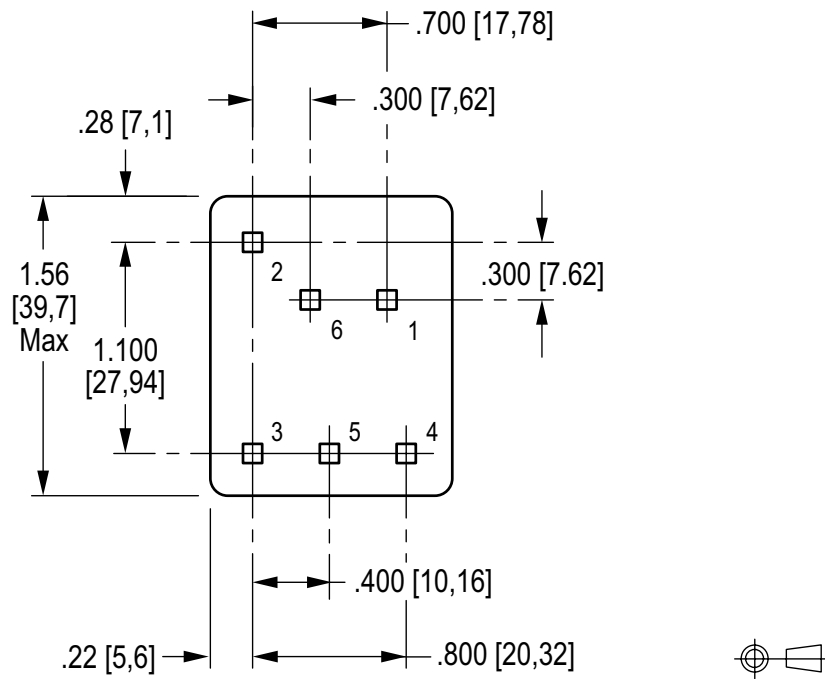
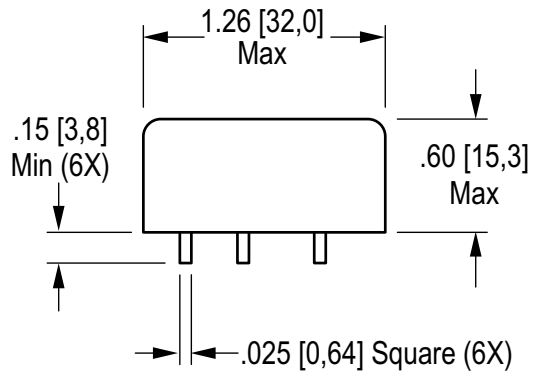

* This product assembly meets IPC-A-610 Class II Standards.

Mass: 39 grams

Pin Designations			
Input		Output	
1	Vin (+)	3	Vout (common)
2	Vin (-)	4	Vout (AC) tube 1
6	Control	5	Vout (AC) tube 2

Specifications Subject to Change Without Notice



Endicott Research Group, Inc.

2601 Wayne St., Endicott, NY 13760

607-754-9187 Fax 607-754-9255

<http://www.ergpower.com>