



Endicott Research Group, Inc.

2601 Wayne St., Endicott, NY 13760
 607-754-9187 Fax 607-754-9255
<http://www.ergpower.com>

Specifications and Applications Information

02/08/06

Preliminary

The ERG DmF63446 (DmF Series) DC to AC inverter features onboard connectors and can be easily dimmed using an external pulse-width modulated control signal or using the onboard PWM with an external analog voltage. This unit is less than 9mm in height and the six mounting holes makes installation very straight forward.

Powered by a regulated 12 Volt DC source, the DmF63446 is designed to power the Fujitsu FLC51XC8V-10LA 6 lamp backlight, with onboard PWM.

Product Features

- ✓ Small Package Size, less than 9mm in height.
- ✓ High Dimming Ratio (Greater than 1000:1)
- ✓ High Efficiency
- ✓ Made in U.S.A.

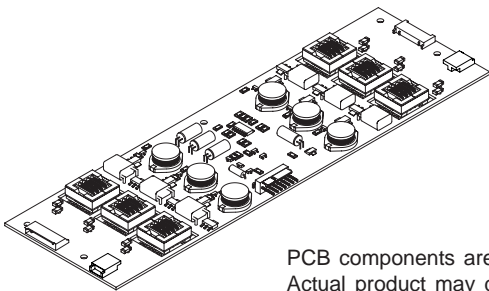

DmF Package

PCB components are shown for reference only. Actual product may differ from that shown.

Connectors

Input Molex 22-05-3071	Output (J2,J3) JST SM04(9-E2)B-BHS
	Output (J4,J5) JST SM02B-BHSS-1-TB

DmF63446

Six Lamp DC to AC Inverter

Package Configuration

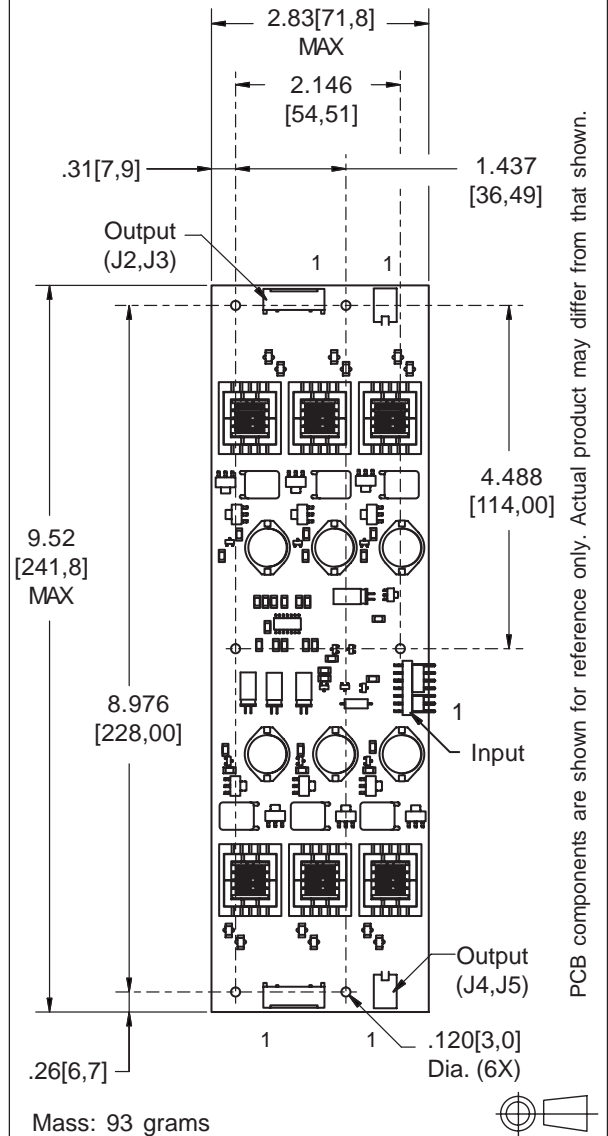

Pin Descriptions

J1-1 Vin	J2,J3-1 ACout
J1-2 Vin	J2,J3-2 ACout
J1-3 GND	J2,J3-3 ACreturn
J1-4 GND	J2,J3-4 ACreturn
J1-5 Enable/PWM	
J1-6 Control	
J1-7 N/C	
	J4,J5-1 ACout
	J4,J5-2 ACreturn



Absolute Maximum Ratings (Note 1)

Rating	Symbol	Value	Units
Input Voltage	V_{in}	-0.3 to +13.2	V_{DC}
Disable	$V_{Disable}$	-0.3 to +0.3	V_{DC}
Operating Temperature	T_a	-0 to +70	°C
Storage Temperature	T_s	-40 to +85	°C

Recommended Operating Conditions

Rating	Symbol	Value	Units
Input Voltage	V_{in}	+10.8 to 12.6	Vdc
Operating Temperature (Note 2)	T_a	0 to +70	°C

Electrical Characteristics

Unless otherwise noted $V_{in} = 12.00$ Volts dc and $T_a = 25^\circ\text{C}$ and unit has been running for 20 minutes.

Characteristic	Symbol	Min	Typ	Max	Units
Input Current	I_{in}	-	2.7	3.1	A_{DC}
Input Ripple Current	I_{rip}	-	60	-	mA_{pk-pk}
Operating Frequency	F_o	25	30	35	KHz
Efficiency	h	-	92	-	%
Output Voltage (no load)	V_{start}	2300	-	-	V
Output Voltage (with lamp)	V_{out}	-	800	-	V
Output Current (per lamp)	I_{out}	-	6.2	-	mArms
Enable (pin J1-5)					
Turn-off Threshold	V_{thoff}	-	-	2	V
Turn-On Threshold	V_{thon}	4	-	-	V
Impedance to V_{in}	$R_{Disable}$	45	47	50	Kohms

(Note 1) Reliable and predictable operation of the device is not guaranteed with applied stresses at or beyond those listed in "Absolute Maximum Ratings". Operation at these limits may reduce device reliability and is therefore not recommended. Please refer to "Recommended Operating Conditions" for reliable operation of the device.

(Note 2) Reliable operation above 70°C is possible if airflow is provided.

Application Notes:

- 1) The minimum distance from high voltage areas of the inverter to any conductive material should be .12 inches per kilovolt of starting voltage.
- 2) Mounting hardware should be non-conductive.
- 3) Open framed inverters should not be used in applications at altitudes over 10,000 feet.
- 4) Contact ERG for possible exceptions.



Onboard PWM

Unless otherwise noted $V_{in} = 12.00$ Volts DC , $T_a = 25$ °C and unit has been running for 20 minutes.

Characteristic	Symbol	Min	Typ	Max	Units
Frequency	f_{pwm}	-	160	-	Hz
Control Full On	V_{ctrl}	-	<.5	-	V
Control Full Off	V_{ctrlh}	-	>4.5	-	V
Control Input Bias Current	I_{cbias}	-	-	10	uA

Pin Descriptions

- Vin** Input voltage to the inverter. Both pins should be connected for optimum reliability and efficiency .
- GND** Inverter ground. Both pins should be connected for optimum reliability and efficiency.
- Control** Analog voltage input to the onboard pulse width modulator. Increasing this voltage increases the off time of the onboard PWM resulting in decreased brightness.
- Enable/Disable** Inverter Enable/Disable. If this pin is driven high, the inverter is enabled. Pull this pin low to disable inverter operation.

Application information

The DmF series of inverters is designed to power up to six cold cathode fluorescent lamps with combined power of up to sixty watts. An external enable/disable control and an onboard analog controlled pulse width modulator provide flexibility in allowing either PWM or analog methods for dimming. The DmF inverter can reliably dim to less than 0.5% duty cycle, which results in an electrical dimming ratio of greater than 200:1. Depending upon the attached backlight assembly, optical dimming ratios of greater than 1000:1 can be accomplished. Graph 1 shows the relationship of relative brightness to duty cycle for a typical backlight assembly.

External shutdown or external PWM operation of the inverter is accomplished using the Enable/Disable pin. Enabling the inverter is accomplished by pulling this pin high (above V_{thon}). Pulling this pin low (below V_{thoff}) disables the inverter.

If analog voltage dimming is required, the onboard PWM can be enabled. The analog voltage is applied to the Control pin. Figure 1 shows how to connect the inverter for onboard PWM operation. Graph 2 shows the relationship of PWM duty cycle to input control voltage.

If more than one inverter is used in a backlight assembly, the PWM signal for each inverter should be synchronized to prevent flickering. Connect the Enable/Disable pin of each inverter to the external PWM source. Connect the control pin to GND.

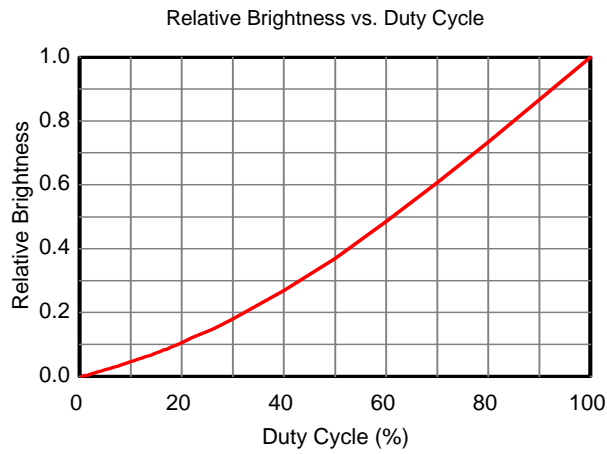

Graph 1

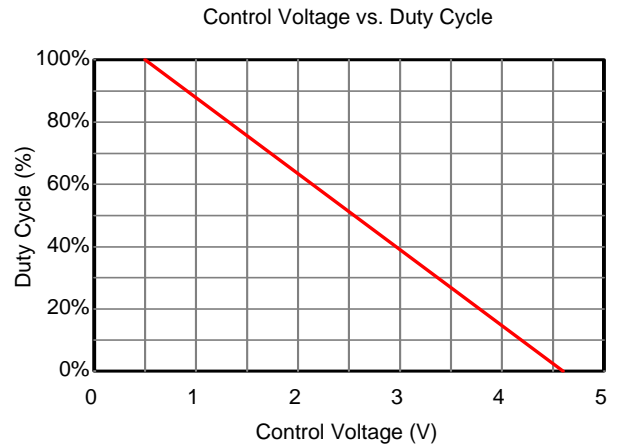

Graph 2

Typical Application

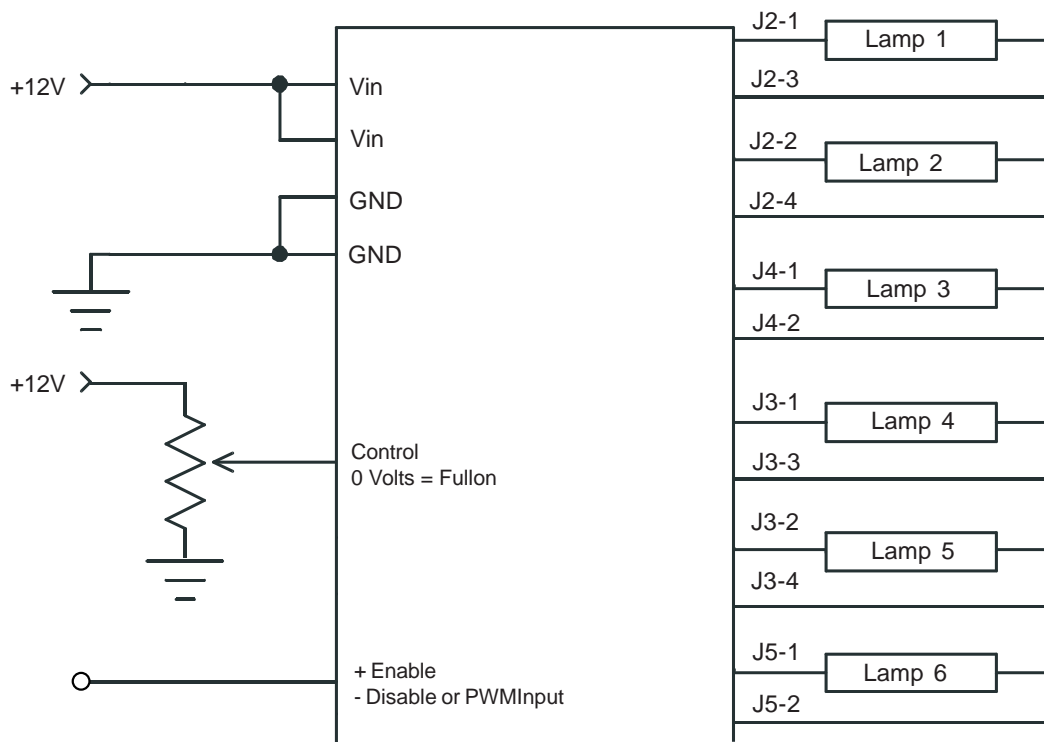

Figure 1



Endicott Research Group, Inc. (ERG) reserves the right to make changes in circuit design and/or specifications at any time without notice. Accordingly, the reader is cautioned to verify that data sheets are current before placing orders. Information furnished by ERG is believed to be accurate and reliable. However, no responsibility is assumed by ERG for its use.