



Endicott Research Group, Inc.

2601 Wayne St., Endicott, NY 13760
 607-754-9187 Fax 607-754-9255
<http://www.ergpower.com>

Specifications and Applications Information

01/18/11

The ERG DMF63191 (DMF Series) DC to AC inverter features onboard connectors and can be easily dimmed using an external pulse-width modulated control signal or using the onboard PWM with an external analog voltage. This unit is less than 9mm in height and the six mounting holes make installation very straight forward.

Powered by a regulated 12 Volt DC source, the DMF63191 is designed to power the Sharp LQ201U1LW21 6-lamp backlight, with onboard PWM.

Product Features

- ✓ Small Package Size, less than 9mm in height
- ✓ High Dimming Ratio (Greater than 1000:1)
- ✓ High Efficiency
- ✓ Made in U.S.A.

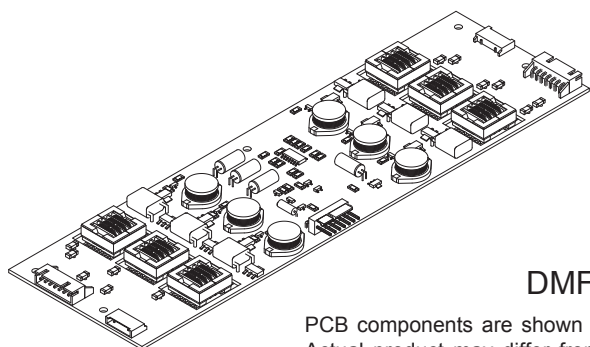

DMF Package

PCB components are shown for reference only. Actual product may differ from that shown.

Connectors

Input J1
 Molex
 22-05-3071

Output J3, J5
 JST
 SM03(4.0)B-BHS-1-TB

Output J2, J4
 JST
 S7B-XH-A

DMF63191

Six Lamp DC to AC Inverter

Package Configuration

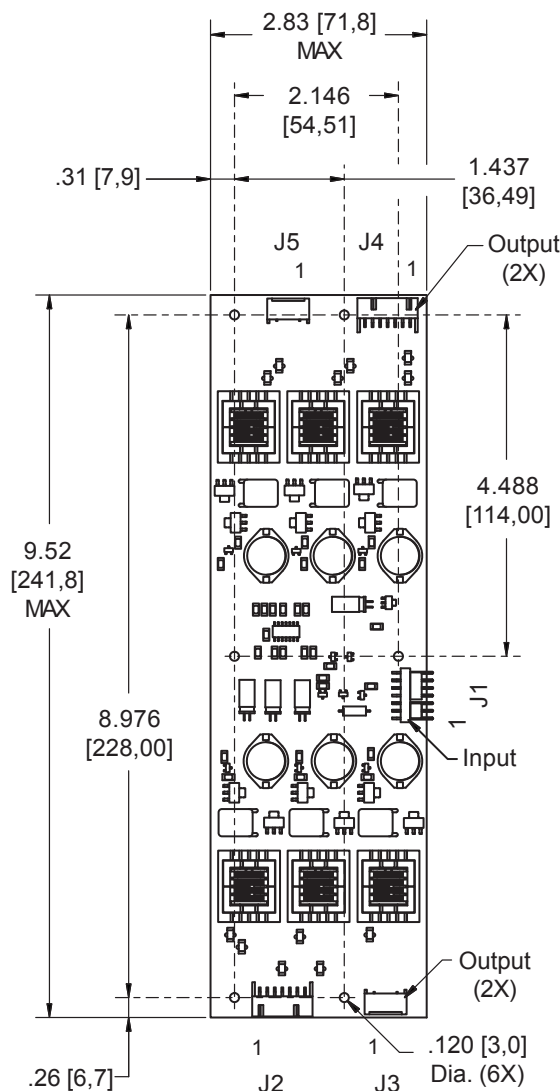

PCB components are shown for reference only. Actual product may differ from that shown.

Mass: 93 grams

Pin Descriptions

J1-1 +Vin	J2,J4-1 ACout
J1-2 +Vin	J2,J4-2 N/C
J1-3 GND	J2,J4-3 N/C
J1-4 GND	J2,J4-4 ACout
J1-5 Enable/PWM	J2,J4-5 N/C
J1-6 Control	J2,J4-6 N/C
J1-7 N/C	J2,J4-7 ACout
	J3,J5-1 ACreturn
	J3,J5-2 ACreturn
	J3,J5-3 ACreturn

**Absolute Maximum Ratings**

Rating	Symbol	Value	Units
Input Voltage Range	V_{in}	-0.3 to +13.2	Vdc
Storage Temperature	T_{stg}	-40 to +85	°C

Operating Characteristics

With a load simulating the referenced display and lamp warm-up of 20 minutes.
Unless otherwise noted $V_{in} = 12.00$ Volts dc and $T_a = 25^{\circ}\text{C}$.

Characteristic	Symbol	Min	Typ	Max	Units
Input Voltage	V_{in}	+10.8	+12.0	+12.6	Vdc
Component Surface Temperature (Note 1)	T_s	-20	-	+80	°C
Input Current (Note 2)	I_{in}	-	2.7	3.1	Adc
Input Ripple Current	I_{rip}	-	60	-	mA_{pk-pk}
Operating Frequency	F_o	25	30	35	kHz
Minimum Output Voltage (Note 3)	$V_{out}(\text{min})$	2300	-	-	Vrms
Efficiency	η	-	92	-	%
Output Current (per lamp)	I_{out}	-	6.2	-	mArms
Output Voltage	V_{out}	-	800	-	Vrms
Enable Pin					
Turn-off Threshold	V_{thoff}	GND	-	0.8	Vdc
Turn-on Threshold	V_{thon}	2.0	-	V_{in}	Vdc
Impedance to V_{in}	R_{Enable}	-	47	-	kOhms

Specifications subject to change without notice.

(Note 1) Surface temperature must not exceed 80 degrees C; thermal management actions may be required.

(Note 2) Input current in excess of maximum may indicate a load/inverter mismatch condition, which can result in reduced reliability. Please contact ERG technical support.

(Note 3) Provided data is not tested but guaranteed by design.

Application Notes:

- 1) The minimum distance from high voltage areas of the inverter to any conductive material should be .12 inches per kilovolt of starting voltage.
- 2) Mounting hardware to be non-conductive.
- 3) Open framed inverters should not be used in applications at altitudes over 10,000 feet.
- 4) ACreturn should be left floating, not grounded.
- 5) Check display wire order and positions on connectors to be sure they match the Pin Descriptions on page 1.
- 6) Contact ERG for possible exceptions.



Onboard PWM

Unless otherwise noted $V_{in} = 12.00$ Volts DC, $T_a = 25$ °C and unit has been running for 20 minutes.

Characteristic	Symbol	Min	Typ	Max	Units
Frequency	f_{pwm}	-	160	-	Hz
Control Full On	V_{ctrl}	-	<.5	-	V
Control Full Off	V_{ctrlh}	-	>4.5	-	V
Control Input Bias Current	I_{cbias}	-	-	10	uA

Pin Descriptions

- Vin** Input voltage to the inverter. Both pins should be connected for optimum reliability and efficiency.
- GND** Inverter ground. Both pins should be connected for optimum reliability and efficiency.
- Control** Analog voltage input to the onboard pulse width modulator. Increasing this voltage increases the off time of the onboard PWM resulting in decreased brightness.
- Enable** Inverter Enable. If this pin is driven high, the inverter is enabled. Pull this pin low to disable inverter operation.

Application information

The DMF series of inverters is designed to power up to six cold cathode fluorescent lamps with combined power of up to sixty watts. An external enable control and an onboard analog controlled pulse width modulator provide flexibility in allowing either PWM or analog methods for dimming. The DMF inverter can reliably dim to less than 0.5% duty cycle, which results in an electrical dimming ratio of greater than 200:1. Depending upon the attached backlight assembly, optical dimming ratios of greater than 1000:1 can be accomplished. Graph 1 shows the relationship of relative brightness to duty cycle for a typical backlight assembly.

External shutdown or external PWM operation of the inverter is accomplished using the Enable pin. Enabling the inverter is accomplished by pulling this pin high (above V_{thon}). Pulling this pin low (below V_{thoff}) disables the inverter.

If analog voltage dimming is required, the onboard PWM can be enabled. The analog voltage is applied to the Control pin. Figure 1 shows how to connect the inverter for onboard PWM operation. Graph 2 shows the relationship of PWM duty cycle to input control voltage.

If more than one inverter is used in a backlight assembly, the PWM signal for each inverter should be synchronized to prevent flickering. Connect the Enable pin of each inverter to the external PWM source. Connect the control pin to GND.

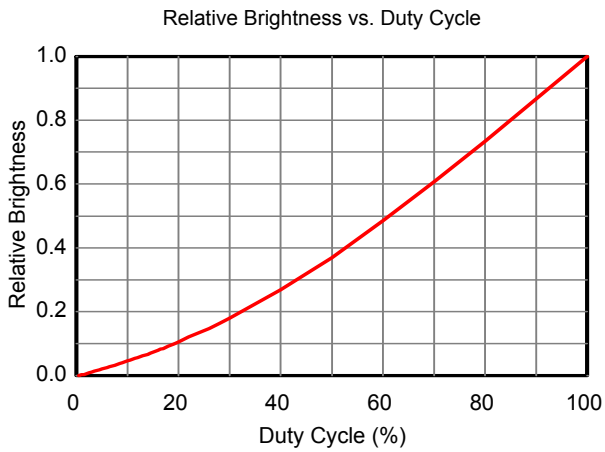

Graph 1

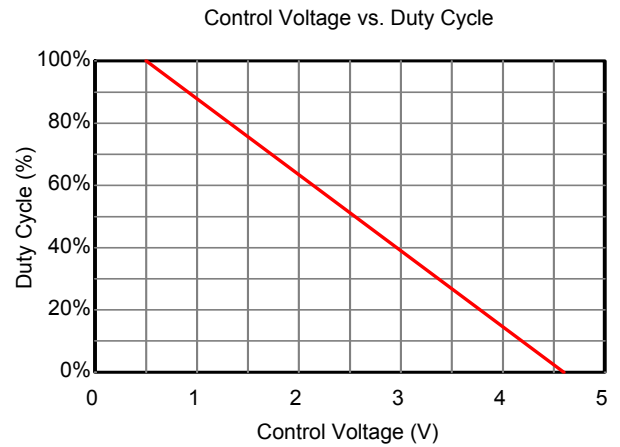

Graph 2

Typical Application

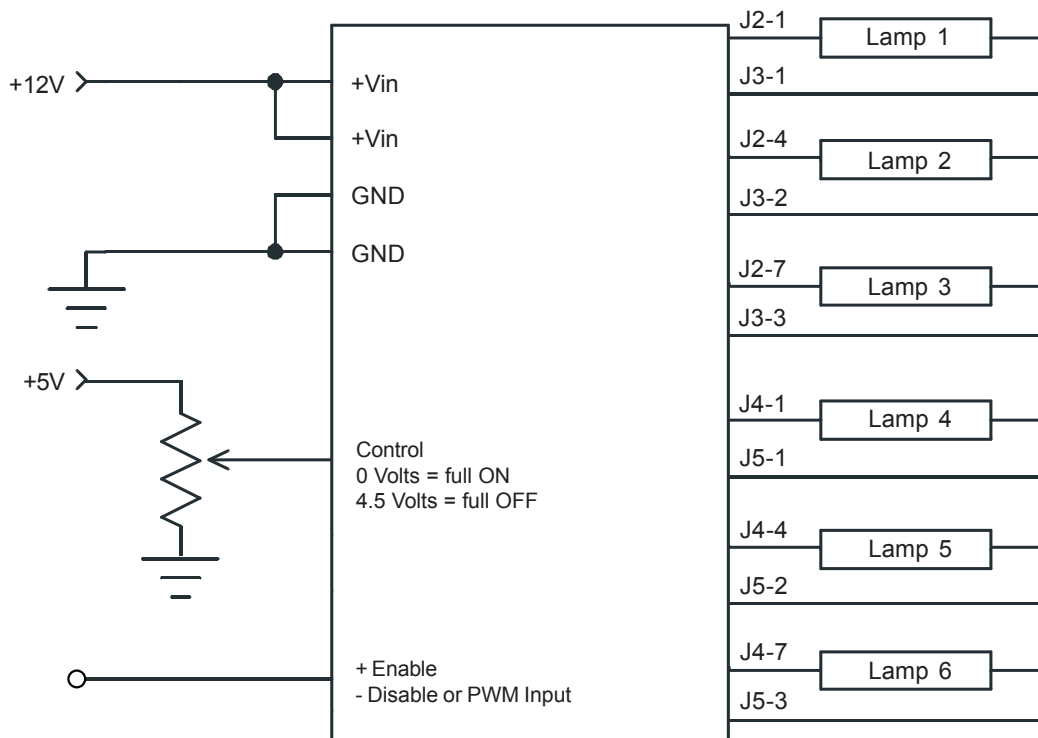

Figure 1



Endicott Research Group, Inc. (ERG) reserves the right to make changes in circuit design and/or specifications at any time without notice. Accordingly, the reader is cautioned to verify that data sheets are current before placing orders. Information furnished by ERG is believed to be accurate and reliable. However, no responsibility is assumed by ERG for its use.