



Endicott Research Group, Inc.
 2601 Wayne St., Endicott, NY 13760
 607-754-9187 Fax 607-754-9255
<http://www.ergpower.com>

DMD43050

Specifications and Applications Information

04/23/04

Preliminary

Four Tube DC to AC Inverter

The ERG DMD43050 (DMD Series) DC to AC inverter features onboard connectors and can be easily dimmed using the onboard PWM Dimming or an external PWM generator.

Powered by a regulated +12 Volt DC source, the DMD43050 is designed to power the backlight of the AU Optronics M170EN05.

Product Features

- ✓ Small Package Size, less than 13mm in height.
- ✓ High Dimming Ratio
- ✓ High Efficiency
- ✓ Made in U.S.A.

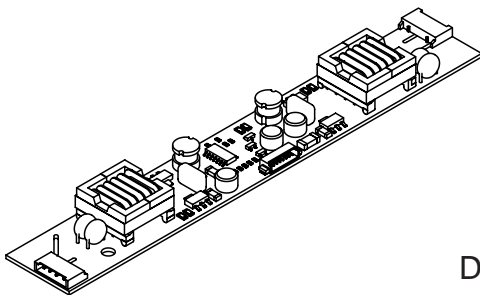

DMD Package

PCB components are shown for reference only.
 Actual product may differ from that shown.

Package Configuration

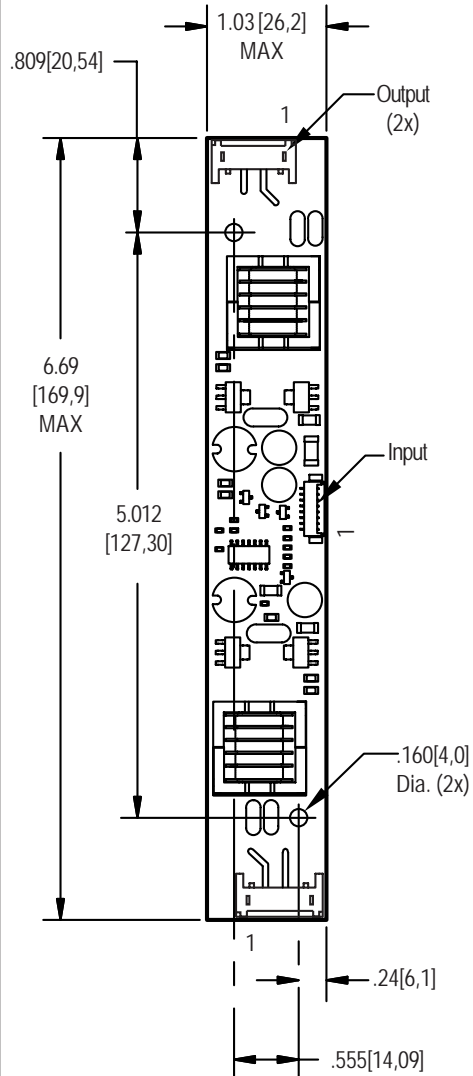

Mass: 45 grams

Pin Descriptions

J2-1 ACout	J1-1 Vin	J3-1 ACout
J2-2 ACout	J1-2 Vin	J3-2 ACout
J2-3 ACcommon	J1-3 GND	J3-3 ACcommon
J2-2 ACcommon	J1-4 GND	J3-2 ACcommon
	J1-5 Enable	
	J1-6 Control	
	J1-7 GND	
	J1-8 GND	

Connectors

Connectors	
Output JST SM04(4.0)B-BHS-1-TB	Input Molex 532-61-0890



Absolute Maximum Ratings (Note 1)

Rating	Symbol	Value	Units
Input Voltage	V_{in}	-0.3 to +13.2	Vdc
Operating Temperature	T_a	-0 to +85	°C
Storage Temperature	T_s	-40 to +85	°C

Recommended Operating Conditions

Rating	Symbol	Value	Units
Input Voltage	V_{in}	+10.8 to 12.6	Vdc
Operating Temperature <small>(Note 2)</small>	T_a	0 to +50	°C

Electrical Characteristics

Unless otherwise noted $V_{in} = 12.00$ Volts dc and $T_a = 25^\circ\text{C}$

Characteristic	Symbol	Min	Typ	Max	Units
Input Current	I_{in}	-	2.0	2.3	A_{DC}
Input Ripple Current	I_{rip}	-	20	-	mA_{pk-pk}
Operating Frequency	F_o	33	38	43	KHz
Efficiency	η	-	84	-	%
Output Voltage (no load)	V_{start}	1700	-	-	V
Output Voltage (with lamp)	V_{out}	-	700	-	V
Output Current (per tube)	I_{out}	-	7.2	-	mArms
Enable (pin J1-5)					
Turn-off Threshold	V_{thoff}	-	-	1	V
Turn-On Threshold	V_{thon}	2.5	-	-	V
Impedance to V_{in}	$R_{Disable}$	9.5	10.0	10.5	V

(Note 1) Reliable and predictable operation of the device is not guaranteed with applied stresses at or beyond those listed in "Absolute Maximum Ratings". Operation at these limits may reduce device reliability and is therefore not recommended. Please refer to "Recommended Operating Conditions" for reliable operation of the device.

(Note 2) Reliable operation above 50°C is possible if airflow is provided.

Input voltage specification modified for clarity on 4/2004.



Onboard PWM

Unless otherwise noted $V_{in} = 12.00$ Volts DC , $T_a = 25$ °C and unit has been running for 5 minutes.

Characteristic	Symbol	Min	Typ	Max	Units
Frequency	f_{pwm}	-	160	-	Hz
Control Input Bias Current	I_{cbias}	-	-	10	uA

Pin Descriptions

Vin Input voltage to the inverter. The two pins should be connected for optimum reliability and efficiency.

GND Inverter ground. The four pins should be connected for optimum reliability and efficiency.

Control Analog voltage input to the onboard pulse width modulator. Decreasing this voltage increases the ON time of the onboard PWM resulting in increased brightness. The inverter is full ON when this voltage is near inverter ground.

Enable Inverter Enable. Pull this pin low to disable inverter operation. This pin must be high to enable the inverter. The onboard PWM is always utilized.

Application information

The DMD series of inverters is designed to power up to four cold cathode fluorescent tubes. An external analog control interfaces with an onboard pulse width modulator to provide dimming control. The DMD inverter can reliably dim to less than 5% duty cycle.

External shutdown of the inverter is accomplished using the Enable pin. Pulling this pin low (below V_{thoff}) disables the inverter. Enabling the inverter is accomplished by pulling this pin high (above V_{thon}).

If analog voltage dimming is required, the analog voltage is applied to the Control pin. Figure 1 shows how to connect the inverter for onboard PWM operation. Graph 1 shows the relationship of PWM duty cycle to input control voltage.

If an external PWM is used, simply connect the Enable pin to the PWM source and connect the Control pin to inverter Ground. If the onboard PWM is used, connect the analog voltage to the Control pin.

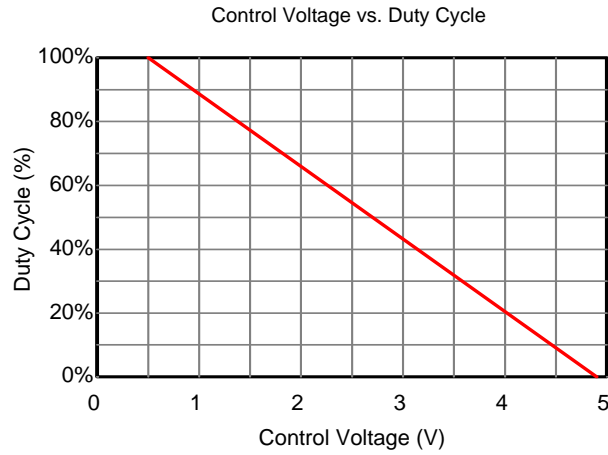

Graph 1

Typical Application

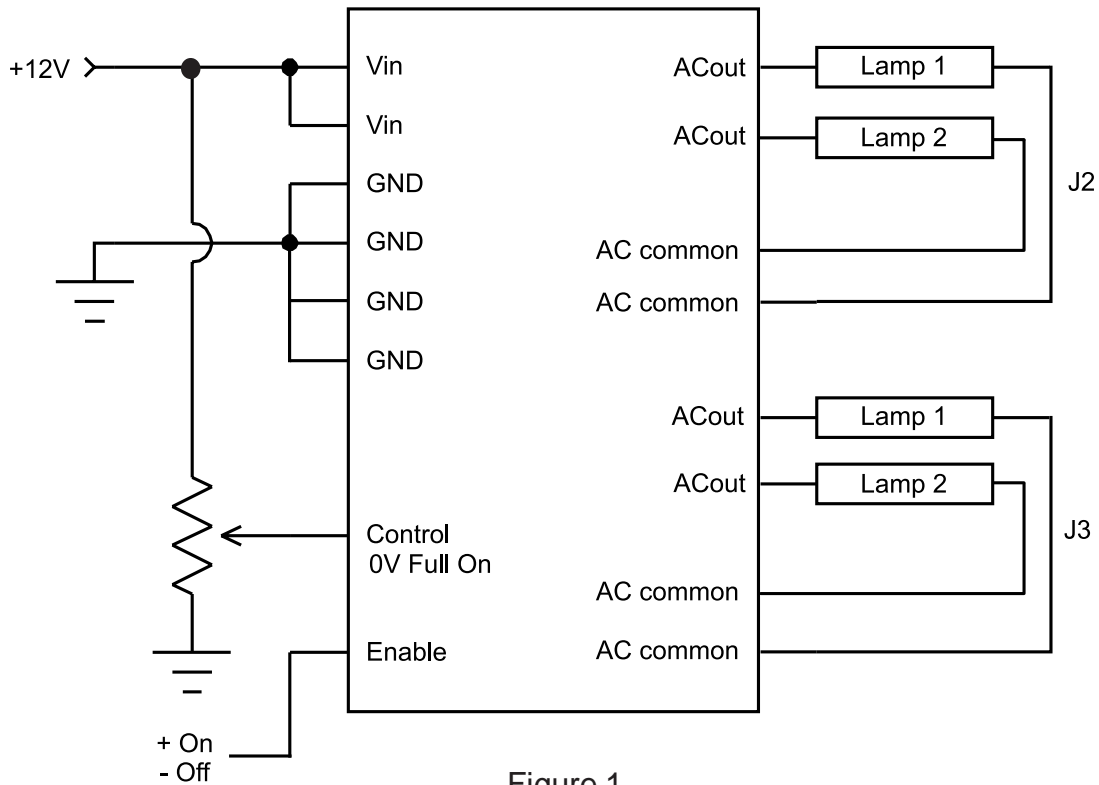

Figure 1



Endicott Research Group, Inc. (ERG) reserves the right to make changes in circuit design and/or specifications at any time without notice. Accordingly, the reader is cautioned to verify that data sheets are current before placing orders. Information furnished by ERG is believed to be accurate and reliable. However, no responsibility is assumed by ERG for its use.