



Endicott Research Group, Inc.

2601 Wayne St., Endicott, NY 13760
607-754-9187 Fax 607-754-9255
http://www.ergpower.com

DMA22902

Specifications and Applications Information

12/27/10

Two Lamp
DC to AC Inverter

The ERG DMA22902 (DMA Series) DC to AC inverter features onboard connectors and can be easily dimmed using an external pulse-width modulated control signal. This unit is less than 13mm in height and the two mounting holes make installation very straight forward.

Powered by a regulated 5 volt DC source the DMA22902 is specially designed to power the Samsung LTM121S1-T01 backlight.

DMA Package

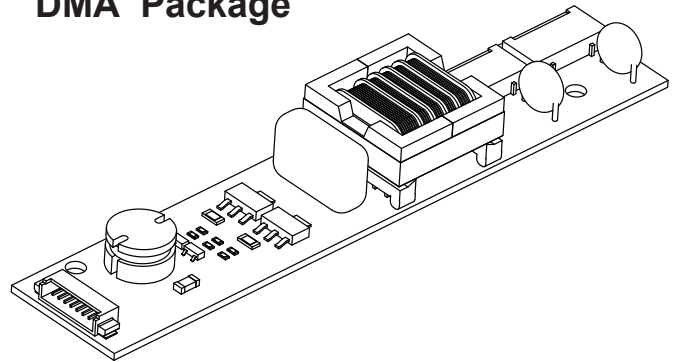

PCB components are shown for reference only.
Actual product may differ from that shown.

Product Features

- ✓ Small Package Size, less than 13mm in height
- ✓ High Efficiency
- ✓ Made in U.S.A.

Package Configuration

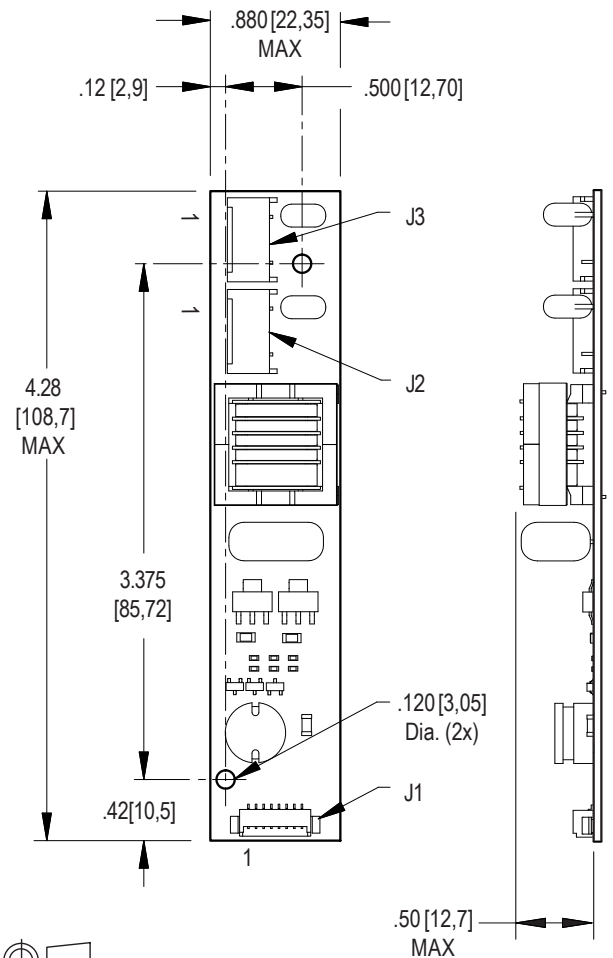

PCB components are shown for reference only. Actual product may differ from that shown.

Connectors

J1 - Input

MOLEX
53261-0871

J2, J3 - Outputs

JST
SM02(8.0)B-BHS-1-TB

Pinouts

J1-1 +Vin	J2-1 ACout
J1-2 +Vin	J2-2 ACreturn
J1-3 GND	
J1-4 GND	
J1-5 Enable/PWM	
J1-6 N/C	J3-1 ACout
J1-7 N/C	J3-2 ACreturn
J1-8 N/C	



Weight: 30 grams

**Absolute Maximum Ratings**

Rating	Symbol	Value	Units
Input Voltage Range	V_{in}	-0.3 to +5.5	Vdc
Storage Temperature	T_{stg}	-40 to +85	°C

Operating Characteristics

With a load simulating the referenced display and lamp warm-up of 5 minutes.
Unless otherwise noted $V_{in} = 5.00$ Volts dc and $T_a = 25^{\circ}\text{C}$.

Characteristic	Symbol	Min	Typ	Max	Units
Input Voltage	V_{in}	+4.50	+5.00	+5.25	Vdc
Component Surface (note 1) Temperature	T_s	-20	-	+80	°C
Input Current (note 2)	I_{in}	-	1.67	2.00	Adc
Input Ripple Current	I_{rip}	-	-	-	mA _{pk-pk}
Operating Frequency	F_o	35	40	45	kHz
Minimum Output Voltage (note 3)	$V_{out}(\text{min})$	1500	-	-	Vrms
Efficiency	η	-	82	-	%
Output Current (per lamp)	I_{out}	-	6.2	-	mArms
Output Voltage	V_{out}	-	550	-	Vrms
Enable Pin					
Turn-off Threshold	V_{thoff}	GND	-	0.5	Vdc
Turn-on Threshold	V_{thon}	2.0	-	V_{in}	Vdc
Enable Input Impedance	R_{Enable}	-	10	-	kOhm

Specifications subject to change without notice.

- (Note 1) Surface temperature must not exceed 80 degrees C; thermal management actions may be required.
 (Note 2) Input current in excess of maximum may indicate a load/inverter mismatch condition, which can result in reduced reliability. Please contact ERG technical support.
 (Note 3) Provided data is not tested but guaranteed by design.

Application Notes:

- 1) The minimum distance from high voltage areas of the inverter to any conductive material should be .12 inches per kilovolt of starting voltage.
- 2) Mounting hardware to be non-conductive.
- 3) Open framed inverters should not be used in applications at altitudes over 10,000 feet.
- 4) ACreturn should be left floating, not grounded.
- 5) Contact ERG for possible exceptions.



Pin Descriptions

- Vin** Input voltage to the inverter. Both pins should be connected for optimum reliability and efficiency.
- GND** Inverter ground. Both pins should be connected for optimum reliability and efficiency.
- Enable** A positive voltage will turn the inverter on. Grounding this pin will turn the inverter off.

Application information

This inverter is designed to power up to two cold cathode fluorescent lamps.

The enable input allows on /off control of the inverter.

An external PWM source applied to this enable input will provide CCFL dimming.

Special Application

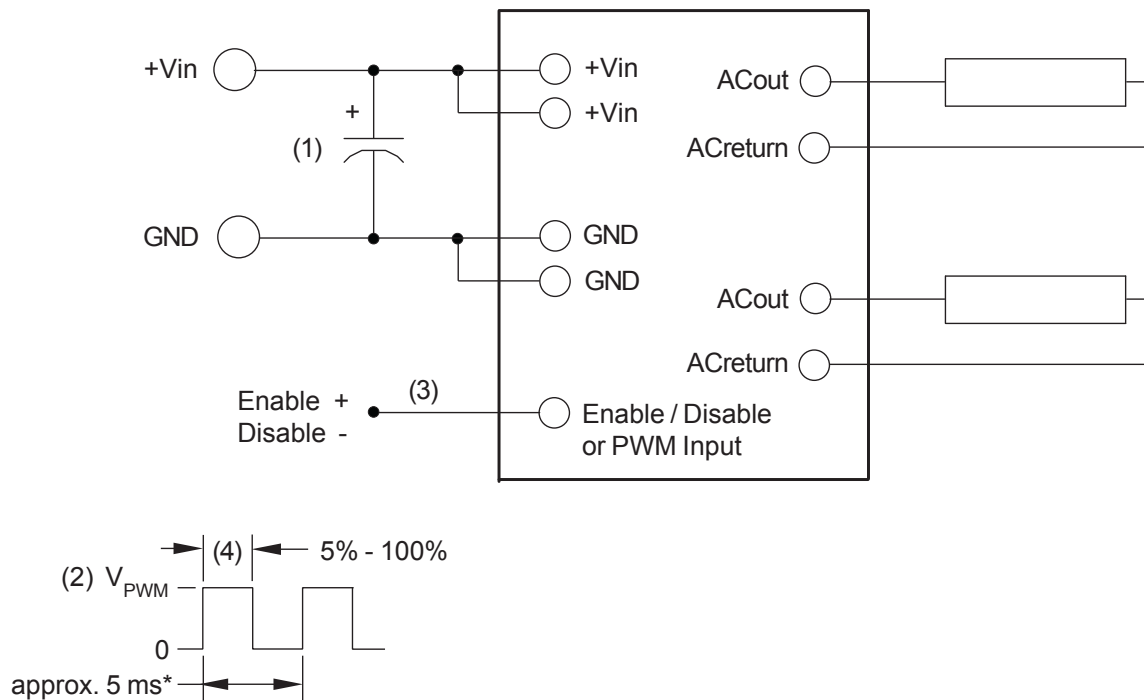

Note 1 Low ESR type input by-pass capacitor (22 uF - 100 uF) may be required to reduce reflected ripple.

Note 2 $V_{P_{PWM}}$ from 2.4V to less than or equal to +Vin.

Note 3 Full brightness without PWM control requires that pin 5 be tied to +Vin, Pin 5 must be at 0V to turn off.

Note 4 Duty Cycle 5% - 100%.



Endicott Research Group, Inc. (ERG) reserves the right to make changes in circuit design and/or specifications at any time without notice. Accordingly, the reader is cautioned to verify that data sheets are current before placing orders. Information furnished by ERG is believed to be accurate and reliable. However, no responsibility is assumed by ERG for its use.