



Endicott Research Group, Inc.

2601 Wayne St., Endicott, NY 13760
607-754-9187 Fax 607-754-9255
http://www.ergpower.com

DMA13142

Specifications and Applications Information

10/26/04

Preliminary

One Lamp
DC to AC Inverter

The ERG DMA13142 (DMA Series) DC to AC inverter features onboard connectors and can be easily dimmed using an external pulse-width modulated control signal. Two mounting holes makes installation very straight forward.

Powered by a regulated +12 volt DC source the DMA13142 is specially designed to power the Sharp LQ070T5DG01, LQ080V3DG01 backlight.

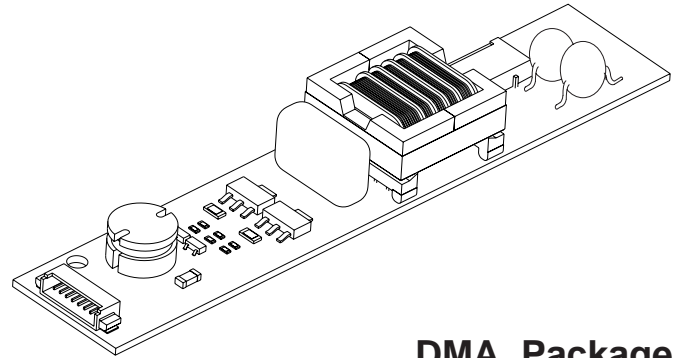

DMA Package

Product Features

- ✓ Small Package Size
- ✓ High Efficiency
- ✓ Made in U.S.A.

Package Configuration

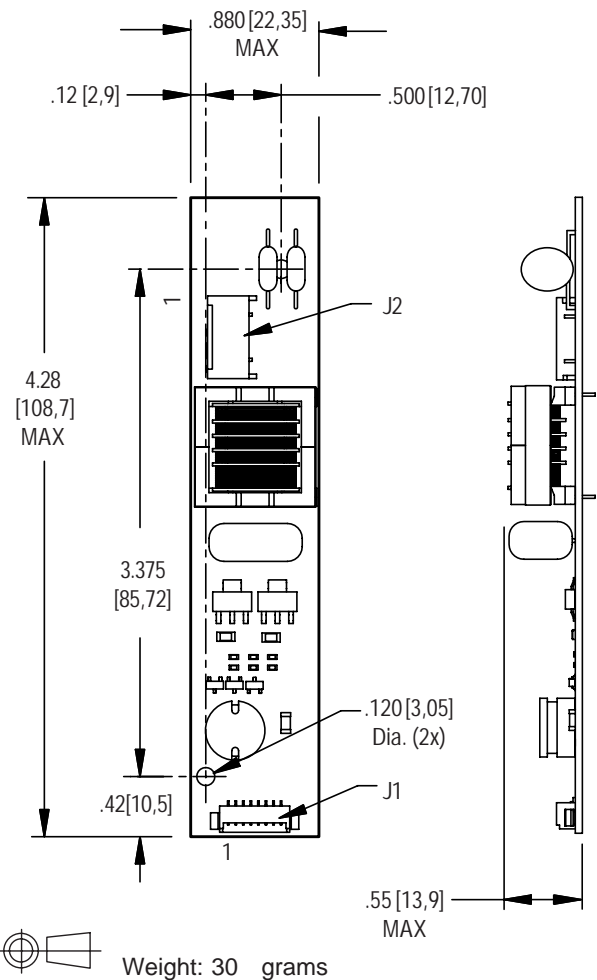

PCB components are shown for reference only. Actual product may differ from that shown.

Connectors

J1 - (Input)
MOLEX
532-61-0890

J2 - (Output)
JST
SM02(8.0)B-BHS-1-TB

Pinouts

| | | | |
|------|----------|------|------------|
| J1-1 | V_{in} | J2-1 | AC_{out} |
| J1-2 | V_{in} | J2-2 | AC_{com} |
| J1-3 | GND | | |
| J1-4 | GND | | |
| J1-5 | Enable | | |
| J1-6 | N/C | J3-1 | N/A |
| J1-7 | N/C | J3-2 | N/A |
| J1-8 | N/C | | |

Absolute Maximum Ratings (Note 1)

| Rating | Symbol | Value | Units |
|-----------------------|--------------|-------------|-------|
| Input Voltage | V_{in} | -0.3 to +15 | Vdc |
| Enable | V_{Enable} | -0.3 to +15 | Vdc |
| Operating Temperature | T_a | -0 to +85 | °C |
| Storage Temperature | T_s | -40 to +85 | °C |

Recommended Operating Conditions

| Rating | Symbol | Value | Units |
|---|----------|--------------|-------|
| Input Voltage | V_{in} | 10.8 to 12.6 | Vdc |
| Operating Temperature <small>(Note 2)</small> | T_a | 0 to +50 | °C |

Electrical Characteristics

Unless otherwise noted $V_{in} = 12.00$ Volts dc and $T_a = 25^\circ\text{C}$

| Characteristic | Symbol | Min | Typ | Max | Units |
|--|-------------|------|-----|-----|---------------------|
| Input Current | I_{in} | - | .55 | .64 | A _{DC} |
| Input Ripple Current | I_{rip} | - | - | - | mA _{pk-pk} |
| Operating Frequency | F_o | 29 | 34 | 39 | KHz |
| Efficiency | η | - | 87 | - | % |
| Output Voltage (no load) <small>(Note 3)</small> | V_{start} | 2050 | - | - | V |
| Output Voltage (with lamp) | V_{out} | - | 860 | - | V |
| Output Current (per lamp) | I_{out} | - | 6.7 | - | mArms |
| Enable (pin J1-5) | | | | | |
| Turn-Off Threshold | V_{thoff} | - | - | 0.7 | V |
| Turn-On Threshold | V_{thon} | 2.0 | - | - | V |

(Note 1) Reliable and predictable operation of the device are not guaranteed with applied stresses at or beyond those listed in "Absolute Maximum Ratings". Operation at these limits may reduce device reliability and is therefore not recommended. Please refer to "Recommended Operating Conditions" for reliable operation of the device.

(Note 2) Operation above 50°C is possible if airflow is provided.

(Note 3) Provided data is not tested but guaranteed by design.

Application Notes:

- 1) The minimum distance from high voltage areas of the inverter to any conductive material should be .12 inches per kilovolt of starting voltage.
- 2) Mounting hardware should be non-conductive.
- 3) Open framed inverters should not be used in applications at altitudes over 10,000 feet.
- 4) Contact ERG for possible exceptions.



Endicott Research Group, Inc.
 2601 Wayne St., Endicott, NY 13760
 607-754-9187 Fax 607-754-9255
<http://www.ergpower.com>





Pin Descriptions

- Vin** Input voltage to the inverter. Both pins should be connected for optimum reliability and efficiency .
- GND** Inverter ground. Both pins should be connected for optimum reliability and efficiency.
- Enable** A positive voltage will turn the inverter on. Grounding this pin will turn the inverter off.

Application information

This inverter is designed to power up to one cold cathode fluorescent lamp.
The enable input allows on /off control of the inverter.
An external PWM source applied to this enable input will provide CCFL dimming.

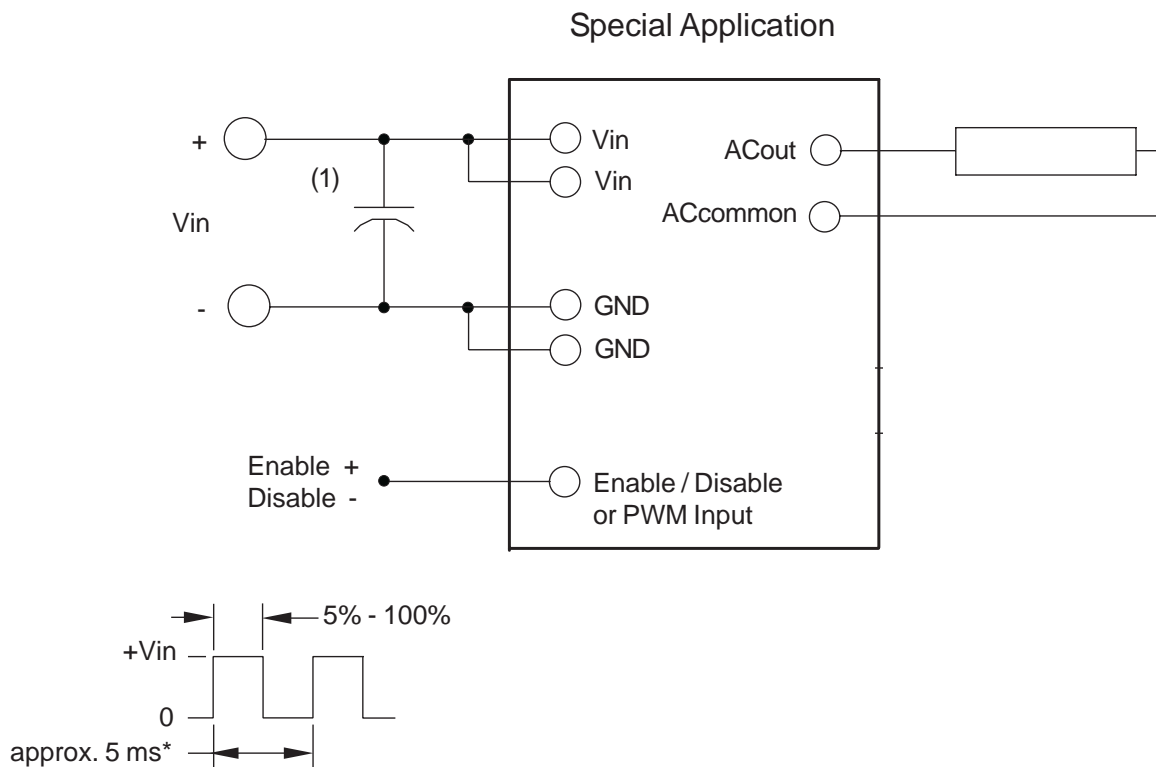

Note 1 Input by-pass capacitor (25uf - 100uf) may be required to reduce reflected ripple.

Endicott Research Group, Inc. (ERG) reserves the right to make changes in circuit design and/or specifications at any time without notice. Accordingly, the reader is cautioned to verify that data sheets are current before placing orders. Information furnished by ERG is believed to be accurate and reliable. However, no responsibility is assumed by ERG for its use.