

D Series



12 Volt Input Dc to Ac Inverter

D12P50

The D12P50 is a generic dc to ac inverter designed to generate 5 mArms into a 270 - 370 Volt load (CCFL) from a nominal 12 Volt dc source.

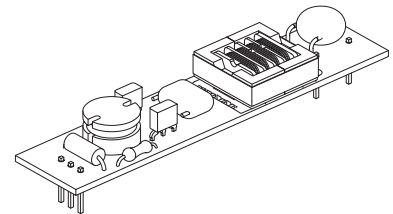
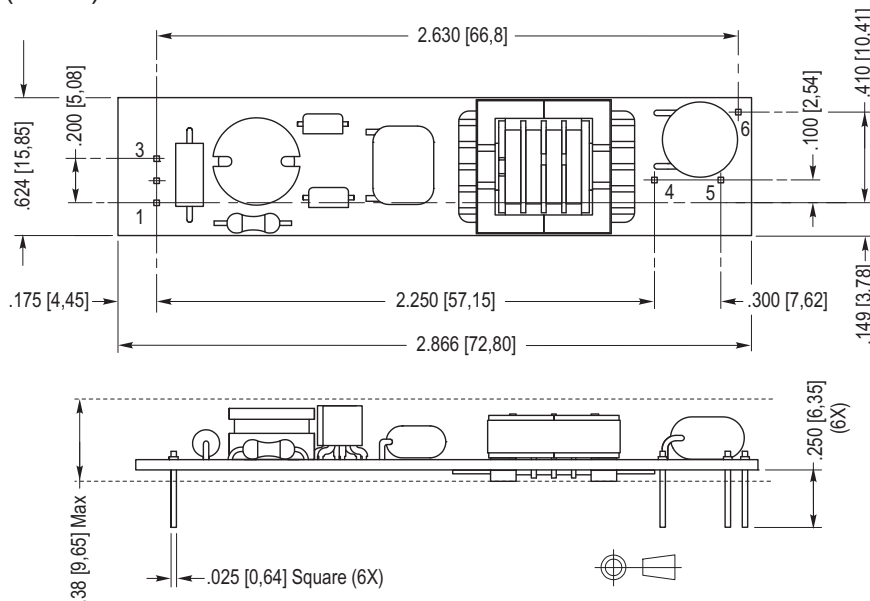

- | | |
|---------------|-------------|
| 1. GND | 4. ACout |
| 2. +Vin | 5. ACreturn |
| 3. Enable/PWM | 6. N/C |

PHYSICAL SPECIFICATIONS

Size: .62" x 2.87" x .38"
 Weight: 12 grams
 Component Surface Temperature: -20° to +80°C
 Storage Temperature: -40° to +85°C
 Humidity: 95% RH (Non-Condensing) Max

Characteristics	Value	Units	Note(s)
Input Voltage	10.8 - 12.6	Vdc	
Input Current	0.18 typ	Adc	$R_L = 64 \text{ kOhms}$
Minimum No Load Output Voltage	1100	Vrms	$V_{in} = 12.00 \text{ Vdc}$
Frequency	36 typ	kHz	$V_{in} = 12.00 \text{ Vdc}$
Output Current	5.0	mArms	$R_L = 64 \text{ kOhms}$
Efficiency	74	%	Typical

The maximum input current (which indicates an overload condition) is 1.0 Adc maximum

FEATURES

Low Profile
 PCB Mountable
 High efficiency

Endicott Research Group, Inc.

2601 Wayne St., Endicott, NY 13760
 607-754-9187 Fax 607-754-9255
<http://www.ergpower.com>

Inverters specifically designed to match most popular LCD modules are also available. Contact your authorized distributor or ERG direct.

Connection and Application Information

12 Volt Input Dc to Ac Inverter

D12P50

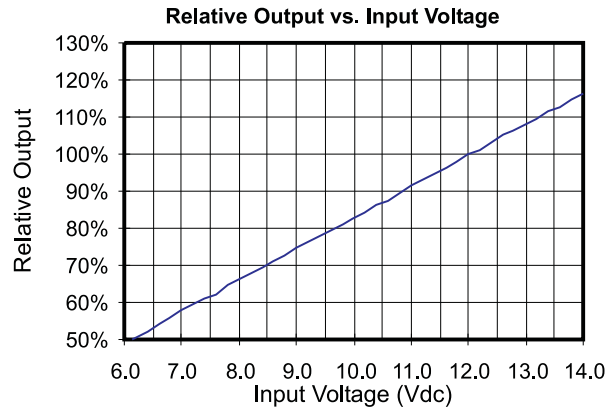
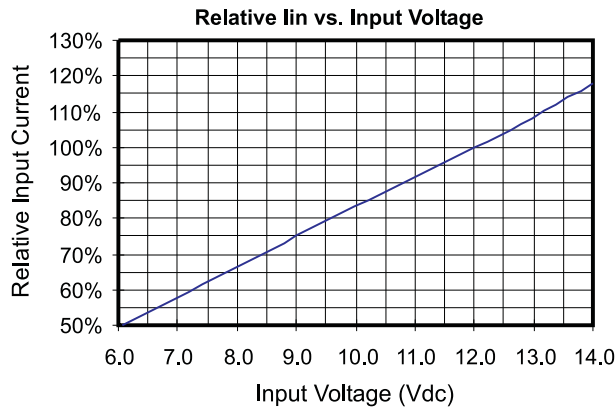

PWM Dimming

Required User Enable/Disable Interface Circuit

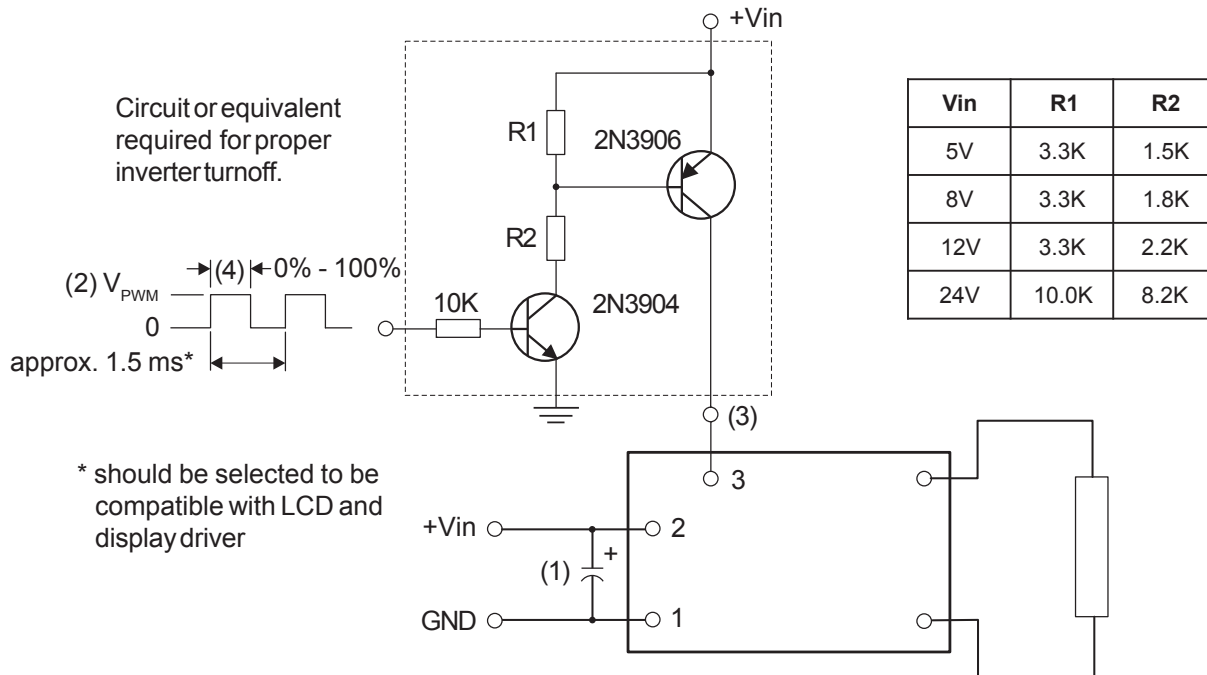

- (1) Low ESR type input by-pass capacitor (22 uf - 100 uf) may be required to reduce reflected ripple.
- (2) V_{PWM} from 2.4V to less than or equal to +V_{in}.
- (3) Full brightness without PWM control requires that pin 3 be tied to +V_{in}. Pin 3 must be at 0V to turn off.
- (4) Duty Cycle 0% - 100%.



Endicott Research Group, Inc.

2601 Wayne St., Endicott, NY 13760
607-754-9187 Fax 607-754-9255
<http://www.ergpower.com>

Specifications are subject to change without notice.

02/09/11

D Series