

D Series



5 Volt Input Dc to Ac Inverter

D05S60

The D05S60 is a generic dc to ac inverter designed to generate 6 mArms into a 350 - 550 Volt load (CCFL) from a nominal 5 Volt dc source.

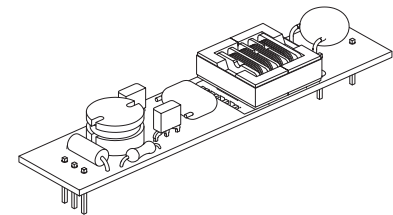
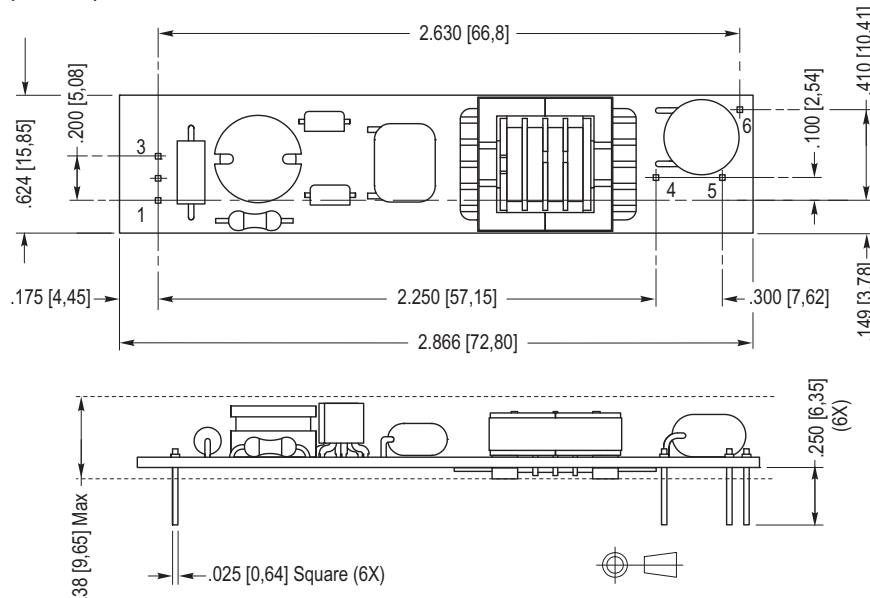

- | | |
|---------------|-------------|
| 1. GND | 4. ACout |
| 2. +Vin | 5. ACreturn |
| 3. Enable/PWM | 6. N/C |

PHYSICAL SPECIFICATIONS

Size: .62" x 2.87" x .38"
 Weight: 12 grams
 Component Surface Temperature: -20° to +80°C
 Storage Temperature: -40° to +85°C
 Humidity: 95% RH (Non-Condensing) Max

Characteristics	Value	Units	Note(s)
Input Voltage	4.50 - 5.25	Vdc	
Input Current	0.72 typ	Adc	$R_L = 75 \text{ kOhms}$
Minimum No Load Output Voltage	1400	Vrms	$V_{in} = 5.00 \text{ Vdc}$
Frequency	39 typ	kHz	$V_{in} = 5.00 \text{ Vdc}$
Output Current	6.0	mArms	$R_L = 75 \text{ kOhms}$
Efficiency	75	%	Typical

The maximum input current (which indicates an overload condition) is 1.0 Adc maximum

FEATURES

Low Profile
 PCB Mountable
 High efficiency

Endicott Research Group, Inc.

2601 Wayne St., Endicott, NY 13760
 607-754-9187 Fax 607-754-9255
<http://www.ergpower.com>

Inverters specifically designed to match most popular LCD modules are also available. Contact your authorized distributor or ERG direct.

Connection and Application Information

5 Volt Input Dc to Ac Inverter

D05S60

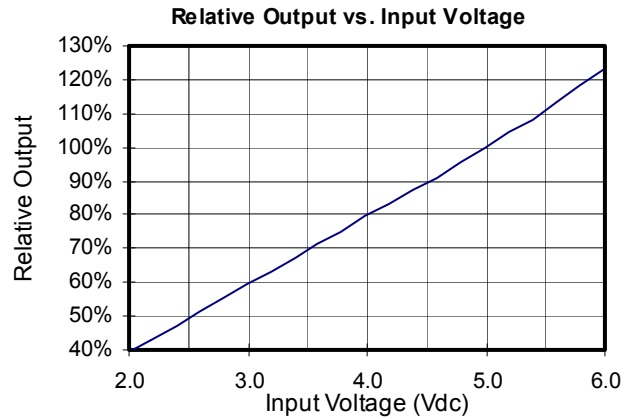
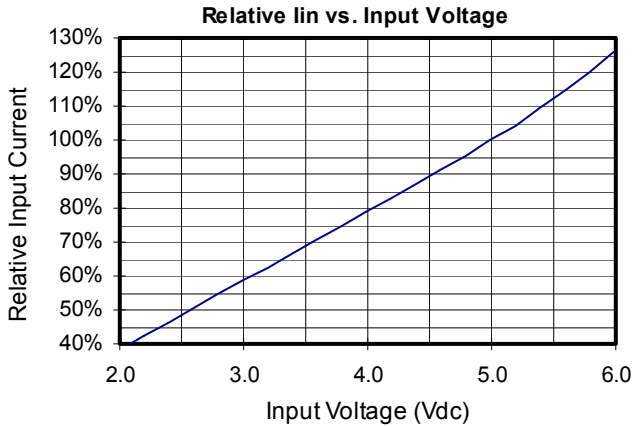

PWM Dimming

Required User Enable/Disable Interface Circuit

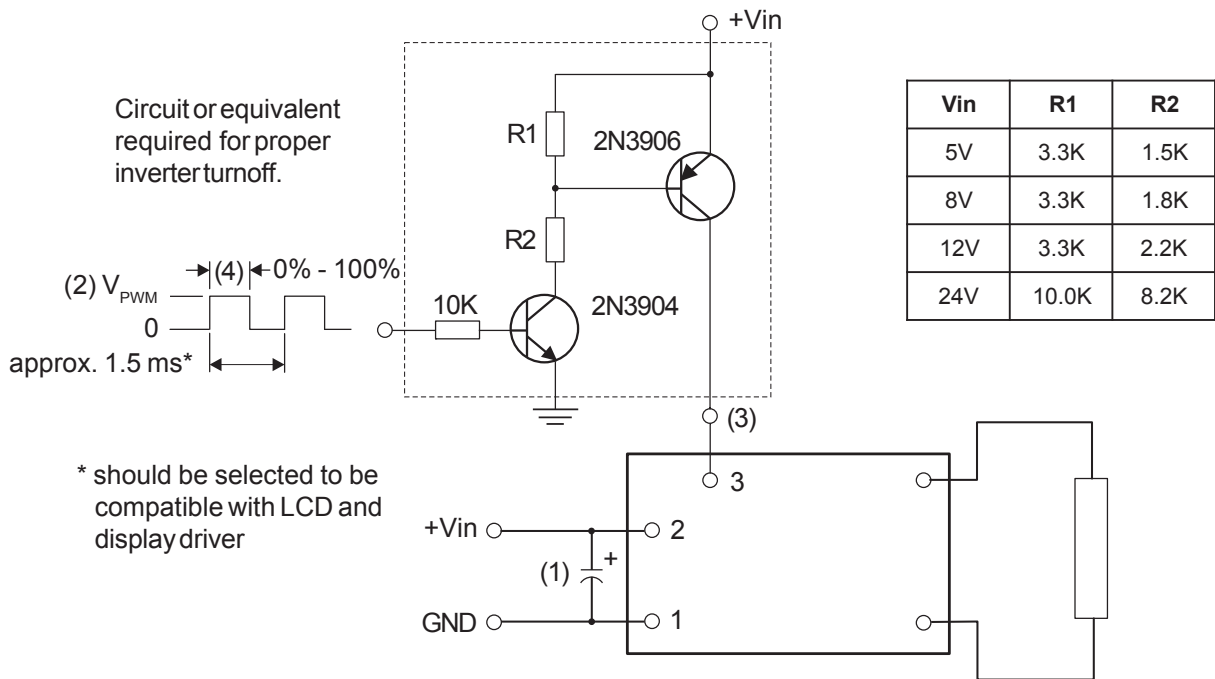

- (1) Low ESR type input by-pass capacitor (22 uf - 100 uf) may be required to reduce reflected ripple.
- (2) V_{PWM} from 2.4V to less than or equal to +Vin.
- (3) Full brightness without PWM control requires that pin 3 be tied to +Vin. Pin 3 must be at 0V to turn off.
- (4) Duty Cycle 0% - 100%.



Endicott Research Group, Inc.

2601 Wayne St., Endicott, NY 13760
 607-754-9187 Fax 607-754-9255
<http://www.ergpower.com>

Specifications are subject to change without notice.

02/09/11

