



Endicott Research Group, Inc.

2601 Wayne St., Endicott, NY 13760
607-754-9187 Fax 607-754-9255
<http://www.ergpower.com>

W6m06JF



Specifications and Applications Information

03/03/11

6m Class
Single Lamp
DC to AC Inverter

The ERG W6m Series of DC to AC inverters is specifically designed for applications which require high efficiency, wide dimming and LCD brightness stability over a wide input voltage range.

Designed, manufactured and supported within the USA, the W6m series features:

- ✓ Less than 6mm in Height
- ✓ Onboard regulation of lamp current
- ✓ High efficiency
- ✓ Open lamp detection
- ✓ Onboard dimming
- ✓ Support for a wide range of displays
- ✓ Footprint compatible with 8m Series
- ✓ Low EMI emission

Package Configuration

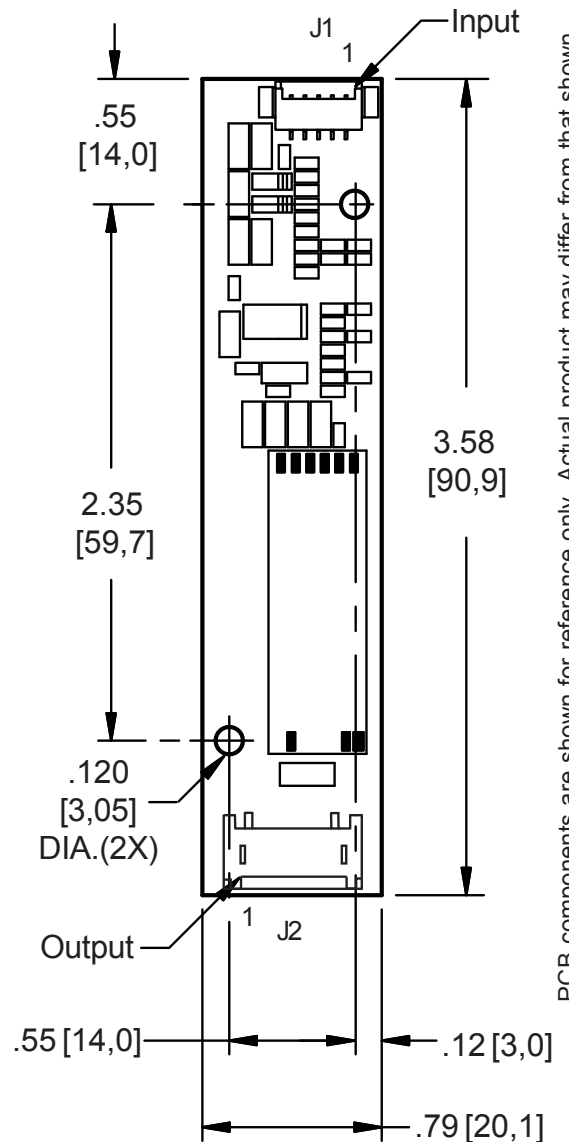

PCB components are shown for reference only. Actual product may differ from that shown.

Connectors

Input Connector	Output Connector
Molex 53261-0571	JST SM02(8.0)B-BHS-1-TB
J1-1 +Vin J1-2 GND J1-3 Enable J1-4 Control J1-5 N/C	J2-1 ACout J2-2 ACreturn



**Absolute Maximum Ratings**

Rating	Symbol	Value	Units
Input Voltage Range	V_{in}	-0.3 to +21.0	Vdc
Enable, Control	$V_{Enable, Control}$	-0.3 to V_{in}	Vdc
Storage Temperature	T_{stg}	-40 to +85	°C

Operating Characteristics

With a simulated load and lamp warm-up of 5 minutes.

Unless otherwise noted $V_{in} = 12.00$ Volts dc and $T_a = 25^\circ\text{C}$, Load = 100 kOhm

Characteristic	Symbol	Min	Typ	Max	Units
Input Voltage (note 1)	V_{in}	+8.0	+12.0	+18.0	Vdc
Component Surface Temperature (note 2)	T_s	-20	-	+80	°C
Input Current (note 3)	I_{in}	-	0.343	0.375	Adc
Operating Frequency	F_o	53	58	63	kHz
Output Voltage (note 4)	V_{start}	-	-	1500	Vrms
Efficiency (note 5)	η	-	87	-	%
Output Current (per lamp) (note 6)	I_{out}	-	6.0	-	mArms
Enable Pin (note 7)					
Turn-off Threshold	V_{thoff}	GND	-	0.5	Vdc
Turn-on Threshold	V_{thon}	2.4	3.3	V_{in}	Vdc

Specifications subject to change without notice.

- (Note 1) V_{in} is measured at the pcb connector. Power cable losses may require that the system power supply or battery, provide a minimum of +8.1 or +8.2 Vdc in order for the inverter to start reliably. Cable losses, and thus specific minimum V_{in} values, will vary by application.
- (Note 2) Surface temperature must not exceed 80 degrees C; thermal management actions may be required.
- (Note 3) Input current in excess of maximum may indicate a load/inverter mismatch condition, which can result in reduced reliability. Please contact ERG technical support.
- (Note 4) Provided data is not tested but guaranteed by design.
- (Note 5) 600 Vrms used in efficiency calculation.
- (Note 6) The output current is measured by inserting a Tektronix CT-2 AC current probe terminated into 50 ohms into the AC Common lead from the load to the inverter.
- (Note 7) It is important that the input voltage to the inverter be within the operating characteristics before the inverter is enabled, otherwise the inverter may not start or may shut down unexpectedly.



Onboard PWM

Unless otherwise noted $V_{in} = +12.00$ Volts DC, $T_a = 25$ °C and unit has been running for 5 minutes.

Characteristic	Symbol	Min	Typ	Max	Units
Frequency	f_{pwm}	-	430	-	Hz
Minimum Brightness	$V_{control}$	0	0.2	0.4	V
Maximum Brightness	$V_{control}$	-	5.0	V_{in}	V

Pin Descriptions

- +Vin** Input voltage to the inverter.
- GND** Inverter ground.
- Control** Analog voltage input to the onboard pulse width modulator. Graph 1 shows the relationship between $V_{control}$ and relative display brightness.
- Enable** Inverter Enable.

Application Information

The W6m series of inverters is designed to power one cold cathode fluorescent lamp from a nonregulated DC power source. Enabling the inverter is accomplished by applying a voltage greater than V_{thon} to the Enable pin of the inverter. It is important that the power supply voltage be above the minimum input voltage specified in Operating Characteristics before enabling the inverter.

Dimming the inverter is accomplished by applying a DC voltage to the Control pin. The applied DC voltage adjusts the duty cycle of the onboard PWM controller thereby changing the brightness of the backlight. Graph 1 shows the typical brightness versus voltage applied to the control pin.

As with all inverters, it is important to take notice that the voltage present at the output pins is quite high and requires special care to be taken when integrating into the final application. The inverter should not be mounted closer than 0.250" (6.4mm) from any other conductive material. In general, the mounting hardware should be nonconductive. Open frame inverters, like the W6m, are not recommended in applications which require operation above 10,000 feet (3000 meters).

To improve the electrical efficiency of the overall application, the input harness cabling should be less than 12 inches (30 cm). The cable assembly between the inverter and the display is best kept below 4 inches (10 cm). If there are any questions or concerns, please feel free to contact ERG for exceptions or recommendations.

REQUIRED POWER UP SEQUENCE

1. Set V_{in} , Enable and Control to 0(zero) Vdc.
2. Apply V_{in} power.
3. Apply Enable signal.
4. Apply and adjust control signal for desired brightness.

Premature inverter shutdown may occur if the required power up sequence is not adhered to. No specific power down sequence is necessary.



Relative Brightness vs Control Voltage

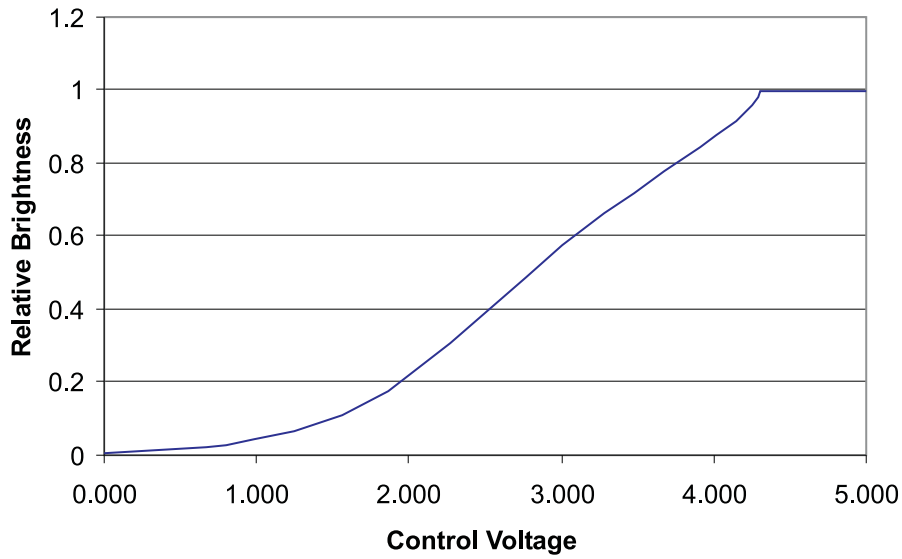

Graph 1

Typical Application

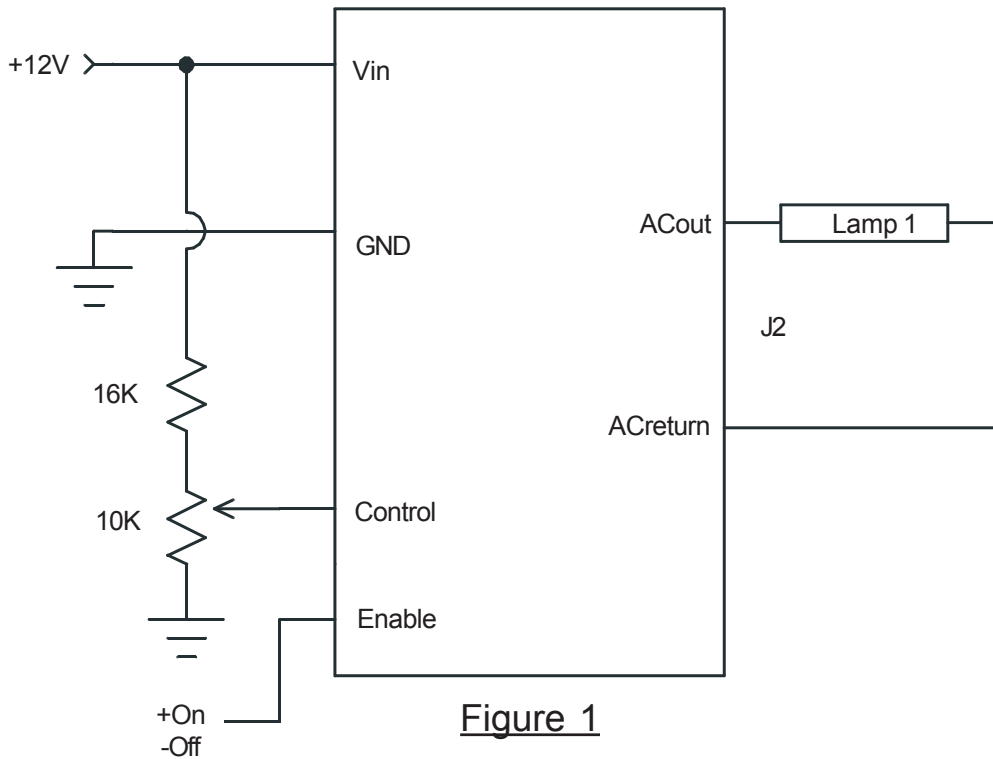

Figure 1



Endicott Research Group, Inc. (ERG) reserves the right to make changes in circuit design and/or specifications at any time without notice. Accordingly, the reader is cautioned to verify that data sheets are current before placing orders. Information furnished by ERG is believed to be accurate and reliable. However, no responsibility is assumed by ERG for its use.