



Endicott Research Group, Inc.

2601 Wayne St., Endicott, NY 13760
607-754-9187 Fax 607-754-9255
http://www.ergpower.com

SFDZDB4275F



Specifications and Applications Information

05/13/13

Smart Force LED Driver

The ERG *Smart Force Series* of LED Drivers are specifically designed for applications which require high efficiency, wide dimming and LCD brightness stability over a wide input voltage range. The SFDZDB4275F is designed to provide backlight power for the IVO M236MWF3 display.

Designed, manufactured and supported within the USA, the SFDZD features:

- ✓ Constant LED current
- ✓ High efficiency
- ✓ On-board PWM dimming
- ✓ High dimming ratio
- ✓ Separate enable and dimming function
- ✓ Open/short circuit protection
- ✓ Soft start
- ✓ One year warranty

Package Configuration

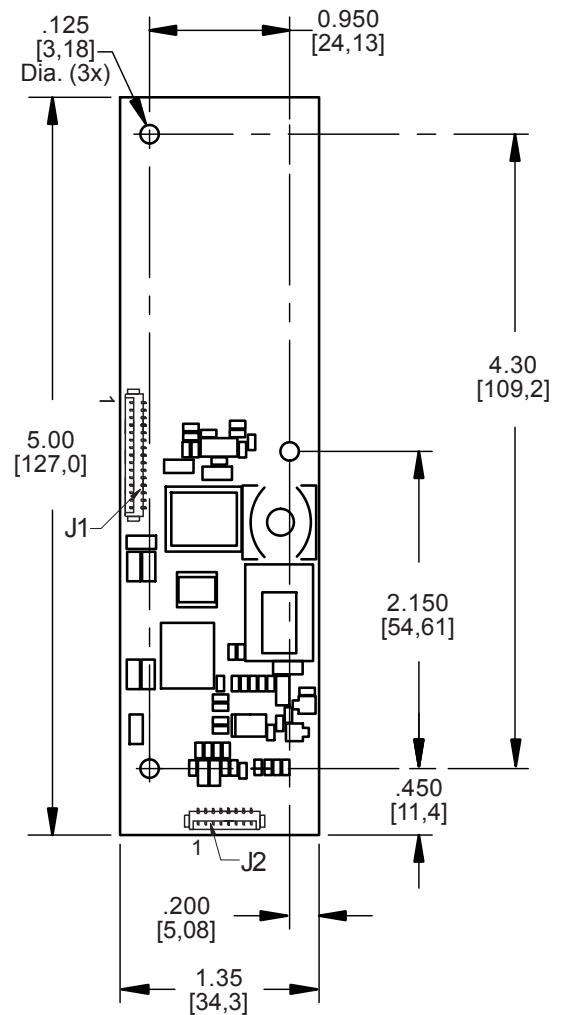

PCB components are shown for reference only. Actual product may differ from that shown.

Mass: 35 grams



Connectors

Input Connector		Output Connector *	
Molex 53261-1571		Molex 53261-0871	
J1-1,2,3	Vin(+)	J2-1	Cathode 1
J1-4,5,6	Vin(+)	J2-2	Anode 1
J1-7,8,9	GND	J2-3	Cathode 2
J1-10,11,12	GND	J2-4	Anode 2
J1-13	Enable	J2-5	Cathode 3
J1-14	N/C	J2-6	Anode 3
J1-15	Control	J2-7	Cathode 4
		J2-8	Anode 4

* Requires harness:
ERG part number H18606152F recommended

**Absolute Maximum Ratings**

Rating	Symbol	Value	Units
Input Voltage Range	V_{in}	-0.3 to +18	Vdc
Storage Temperature	T_{stg}	-40 to +85	°C
Control Voltage	$V_{Control}$	0 to 6.0	Vdc
Enable Input Voltage	V_{Enable}	0 to 6.0	Vdc

Operating Characteristics

Unless otherwise noted $V_{in} = 12.00$ Volts dc and $T_a = 25^{\circ}\text{C}$.

Characteristic	Symbol	Min	Typ	Max	Units
Input Voltage	V_{in}	+10.8	+12.0	+13.2	Vdc
Component Surface Temperature (Note 1)	T_s	-20	-	+80	°C
Input Current (Note 2)	I_{in}	1.16	1.36	1.56	Adc
LED String Voltage	V_{LED}	22	-	35	Vdc
Efficiency (Note 2)	η	-	86	-	%
Output Current (per string)	I_{out}	114	120	126	mArms
Enable Pin					
Turn-on Threshold (Note 3)	V_{thon}	-	-	1.8	Vdc
Turn-off Threshold	V_{thoff}	0.6	-	-	Vdc
Enable Input Impedance (Note 4)	R_{Enable}	-	8.5	-	kOhms
Control Pin (Notes 5,6)					
Full-on Threshold	V_{fon}	-	1.0	-	Vdc
Minimum Pulse Width Threshold	V_{PWmin}	-	4.5	-	Vdc

Specifications subject to change without notice.

- Note 1 Surface temperature must not exceed 80°C ; thermal management actions may be required.
 Note 2 Input Current and Efficiency are calculated with 29V LED strings.
 Note 3 Enable pin is internally pulled up above the Turn-on Threshold.
 Note 4 Enable pin input impedance is $8.5\text{ k}\Omega$ to 3V with 12V input voltage.
 Note 5 Internally pulled up above the Turn-on Threshold.
 Note 6 Control pin input impedance is $485\text{ k}\Omega$.



Onboard PWM

Unless otherwise noted $V_{in} = 12.00$ Volts DC, $T_a = 25$ °C and unit has been running for 5 minutes.

Characteristic	Symbol	Min	Typ	Max	Units
Frequency	f_{pwm}	-	245	-	Hz
Control Input Bias Current	I_{cbias}	-	-	10	μA

Application Information

The ERG SFDZDB4275F has been designed to be configured in multiple ways:

NO DIMMING

- OPERATION: The SFD driver can be configured to operate without dimming by floating the Control Pin (J1-15) and the Enable Pin (J1-13).
- Pins 1 through 6 of connector J1 must be connected to +Vin, between 10.8 and 13.2 Vdc. Pins 7 through 12 of connector J1 must be connected to GND.

ONBOARD PWM DIMMING

- OPERATION: Onboard PWM configuration as shown in Figure 1 allows the user to control display brightness by controlling the onboard PWM generator. The user is responsible to provide an analog control signal. A dimming ratio up to 255:1 is possible with this configuration.
- DIMMING: Dimming is accomplished by applying an analog voltage to the Control Pin (J1-15). Display brightness is modulated by controlling the Control Pin voltage as shown in Graph 1.
- ENABLE/DISABLE: The driver may be enabled or disabled (turned on and off) by applying a DC voltage to the Enable Pin(J1-13). Enable Pin on and off levels are specified in the Operating Characteristics section of the data sheet. The driver can also be enabled by floating the Enable Pin.
- Pins 1 through 6 of connector J1 must be connected to +Vin, between 10.8 and 13.2 Vdc. Pins 7 through 12 of connector J1 must be connected to GND. Pin 14 may be left floating or pulled up.



ONBOARD PWM DIMMING

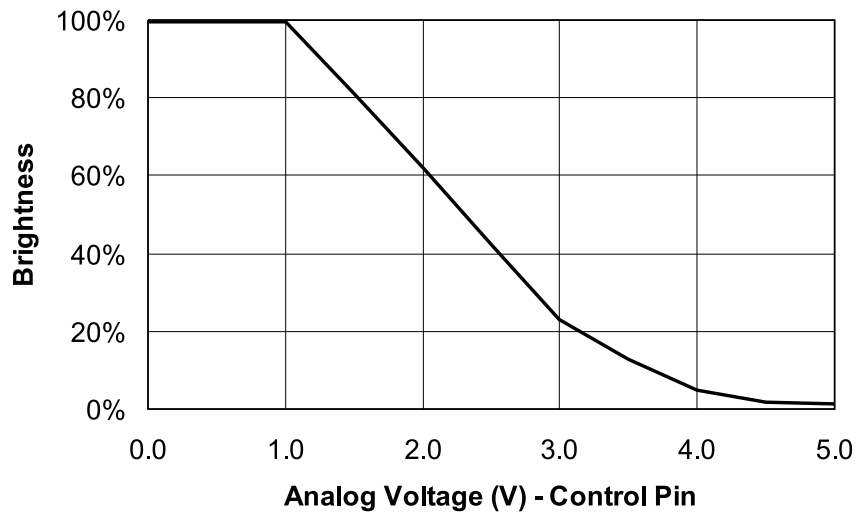

Graph 1

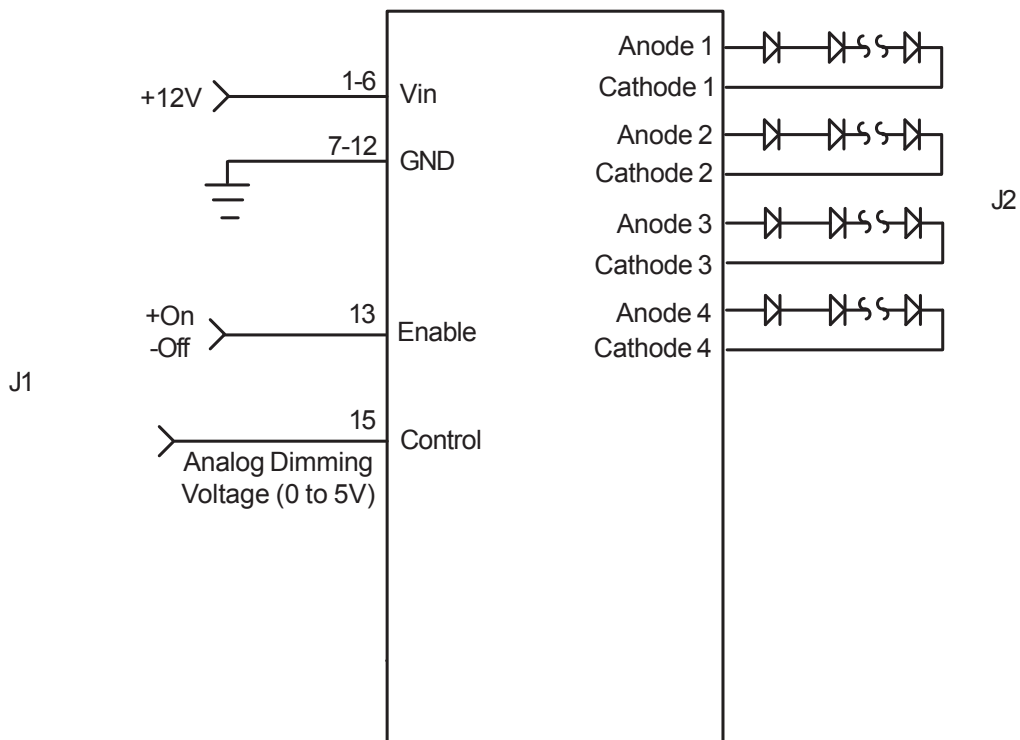

Figure 1



Endicott Research Group, Inc. (ERG) reserves the right to make changes in circuit design and/or specifications at any time without notice. Accordingly, the reader is cautioned to verify that data sheets are current before placing orders. Information furnished by ERG is believed to be accurate and reliable. However, no responsibility is assumed by ERG for its use.