



Endicott Research Group, Inc.

2601 Wayne St., Endicott, NY 13760
607-754-9187 Fax 607-754-9255
http://www.ergpower.com

SFD2CB4012F



Specifications and Applications Information

03/21/11

Smart Force LED Driver

The ERG *Smart Force Series* of LED Drivers are specifically designed for applications which require high efficiency, wide dimming and LCD brightness stability over a wide input voltage range. The SFD2CB4012F is designed to provide backlight power for the AU Optronics G150XG01 V2.

Designed, manufactured and supported within the USA, the SFD2C features:

- ✓ Constant LED current
- ✓ High efficiency
- ✓ External or Internal dimming
- ✓ High dimming ratio
- ✓ Separate enable and dimming function
- ✓ Open/short circuit protection
- ✓ Soft start
- ✓ One year warranty

Package Configuration

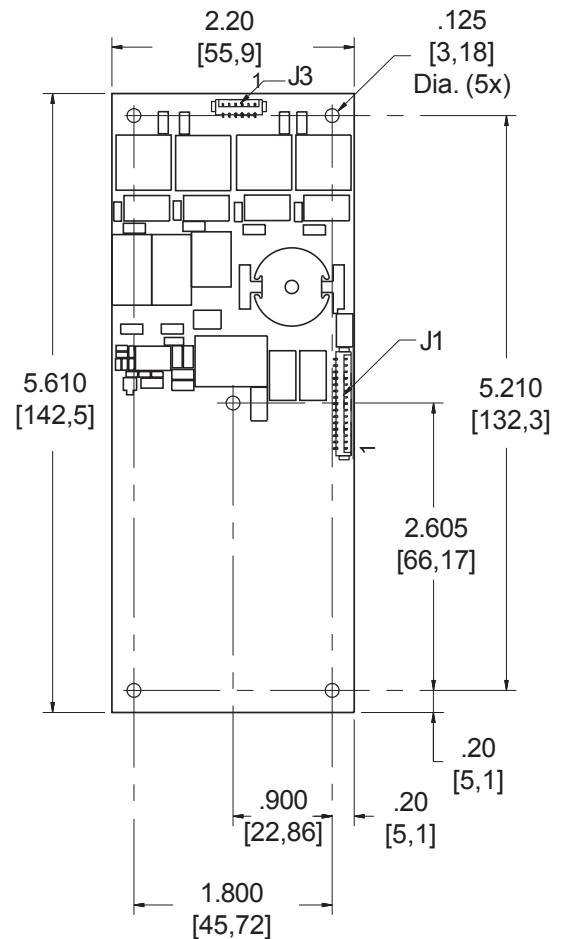

PCB components are shown for reference only. Actual product may differ from that shown.

Mass: 85 grams



Connectors

Input Connector		Output Connectors *	
Molex 53261-1571		Molex 53261-0671	
J1-1,2,3	Vin(+)	J3-1	Cathode 1
J1-4,5,6	Vin(+)	J3-2	Anode 1
J1-7,8,9	GND	J3-3	Cathode 2
J1-10,11,12	GND	J3-4	Anode 2
J1-13	Enable	J3-5	Cathode 3
J1-14	PWM	J3-6	Anode 3
J1-15	Control		

* Requires harness:
ERG part number H13106152 recommended

**Absolute Maximum Ratings**

Rating	Symbol	Value	Units
Input Voltage Range	V_{in}	-0.3 to +18	Vdc
Storage Temperature	T_{stg}	-40 to +85	°C
Control Voltage	$V_{Control}$	0 to 5.0	Vdc
Enable Input Voltage	V_{Enable}	0 to 5.0	Vdc

Operating Characteristics

Unless otherwise noted $V_{in} = 12.00$ Volts dc and $T_a = 25^{\circ}\text{C}$.

Characteristic	Symbol	Min	Typ	Max	Units
Input Voltage	V_{in}	+10.8	+12.0	+18.0	Vdc
Component Surface Temperature (Note 1)	T_s	-40	-	+80	°C
Input Current (Note 2)	I_{in}	0.56	0.66	0.76	Adc
Operating Frequency (Note 3)	F_o	-	450	-	kHz
LED String Voltage	V_{LED}	24	-	34	Vdc
Efficiency (Note 2)	η	-	77	-	%
Output Current (per string)	I_{out}	77	81	85	mArms
Enable Pin (Note 4)					
Turn-on Threshold (Note 5)	V_{thon}	-	-	1.8	Vdc
Turn-off Threshold	V_{thoff}	1.3	-	-	Vdc
Enable Input Impedance (Note 7)	R_{Enable}	-	5.0	-	kOhms
PWM Pin (Note 4)					
Turn-on Threshold (Note 6)	V_{thon}	-	-	1.8	Vdc
Turn-off Threshold	V_{thoff}	1.3	-	-	Vdc
Enable Input Impedance (Note 7)	R_{Enable}	-	5.0	-	kOhms
Control Pin (Note 8)					
Full-on Threshold	V_{fon}	-	0.9	-	Vdc
Full-off Threshold	V_{foff}	-	4.0	-	Vdc

Specifications subject to change without notice.

- Note 1 Surface temperature must not exceed 80°C ; thermal management actions may be required.
- Note 2 Input Current and Efficiency are calculated with 25.2V LED strings.
- Note 3 Hysteretic current control frequency.
- Note 4 The input voltage to the driver must be within its operating characteristic before the driver is enabled, otherwise the driver may not start or may shut down unexpectedly.
- Note 5 Enable pin is internally pulled up above the Turn-on Threshold.
- Note 6 PWM pin is internally pulled up above turn on threshold.
- Note 7 Input Impedance is 5.0kohms to 2.5V.
- Note 8 Control pin is internally held to 2.5V.



Onboard PWM

Unless otherwise noted $V_{in} = 12.00$ Volts DC, $T_a = 25$ °C and unit has been running for 5 minutes.

Characteristic	Symbol	Min	Typ	Max	Units
Frequency	f_{pwm}	-	160	-	Hz
Control Input Bias Current	I_{cbias}	-	-	10	μA

Application Information

The ERG SFD2CB4012F has been designed to be configured in multiple ways:

NO DIMMING

- OPERATION: The SFD driver can be configured to operate without dimming by grounding the Control Pin (J1-15), floating the Enable Pin (J1-13), and floating the PWM Pin (J1-14).
- Pins 1 through 6 of connector J1 must be connected to +Vin, between 10.8 and 18 Vdc. Pins 7 through 12 of connector J1 must be connected to GND.

ONBOARD PWM DIMMING

- OPERATION: Onboard PWM configuration as shown in Figure 1 allows the user to control display brightness by controlling the onboard PWM generator. The user is responsible to provide an analog control signal. A dimming ratio up to 100:1 is possible with this configuration.
- DIMMING: Dimming is accomplished by applying an analog voltage to the Control Pin (J1-15). Display brightness is modulated by controlling the Control Pin voltage as shown in Graph 1.
- ENABLE/DISABLE: The driver may be enabled or disabled (turned on and off) by applying a DC voltage to the Enable Pin (J1-13). Enable Pin on and off levels are specified in the Operating Characteristics section of the data sheet. The driver can also be enabled by floating the Enable Pin.
- Pins 1 through 6 of connector J1 must be connected to +Vin, between 10.8 and 18 Vdc. Pins 7 through 12 of connector J1 must be connected to GND. Pin 14 may be left floating or pulled up.

EXTERNAL PWM DIMMING

- OPERATION: External PWM configuration as shown in Figure 2 allows the user to control display brightness with an externally generated PWM signal. The user is responsible to provide the PWM signal. A dimming ratio up to 10,000:1 is possible with this configuration.
- DIMMING: Dimming is accomplished by applying a PWM signal to the PWM Pin (J1-14). PWM on and off levels are specified in the Operating Characteristics section of the data sheet. Display brightness is modulated by controlling the PWM duty cycle as shown in Graph 2.
- ENABLE/DISABLE: The driver may be enabled or disabled (turned on and off) by applying a DC voltage to the Enable Pin (J1-13). Control Pin on and off levels are specified in the Operating Characteristics section of the data sheet.
- Pins 1 through 6 of connector J1 must be connected to +Vin, between 10.8 and 18 Vdc. Pins 7 through 12 of connector J1 must be connected to GND.



ONBOARD PWM DIMMING

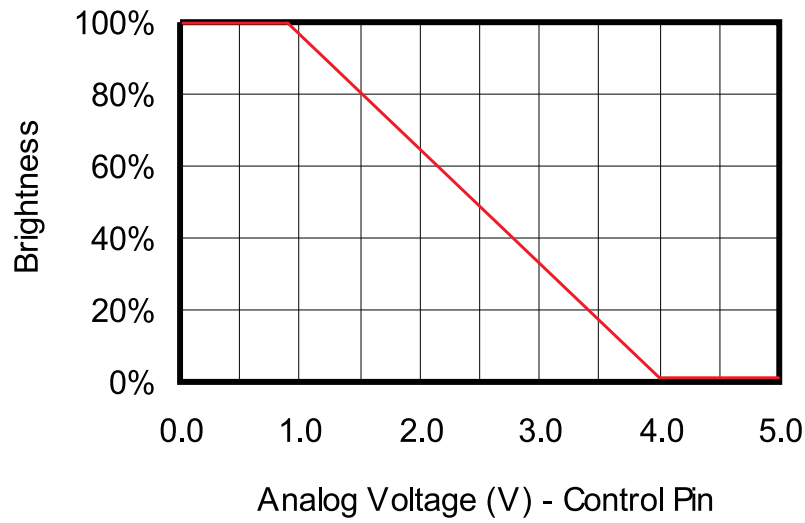

Graph 1

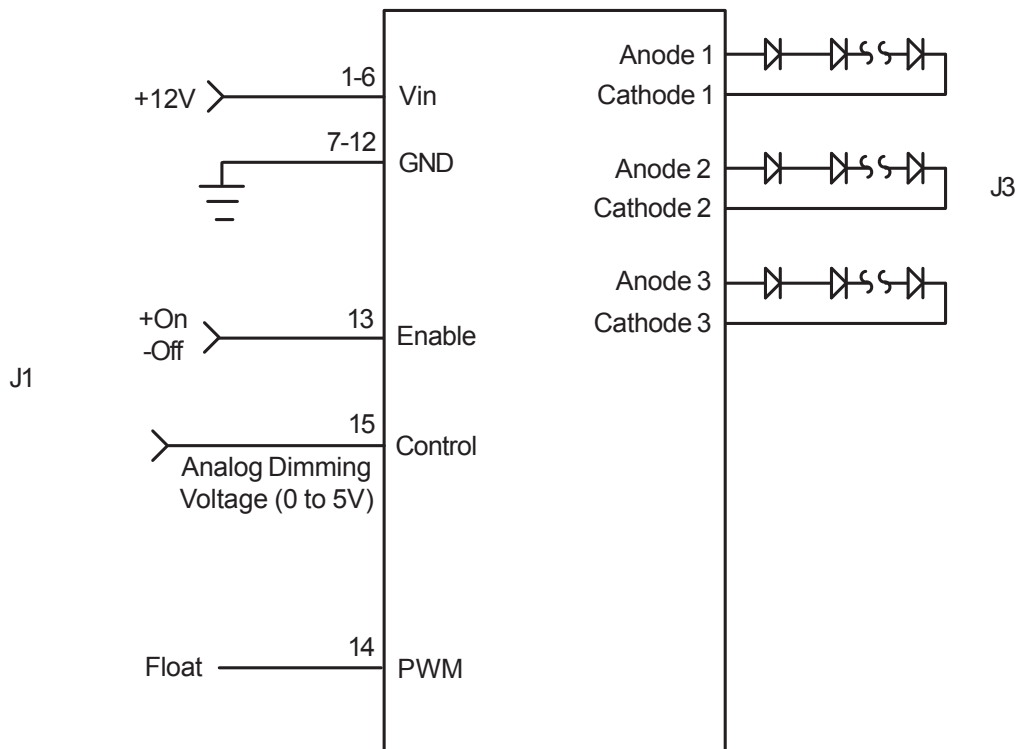
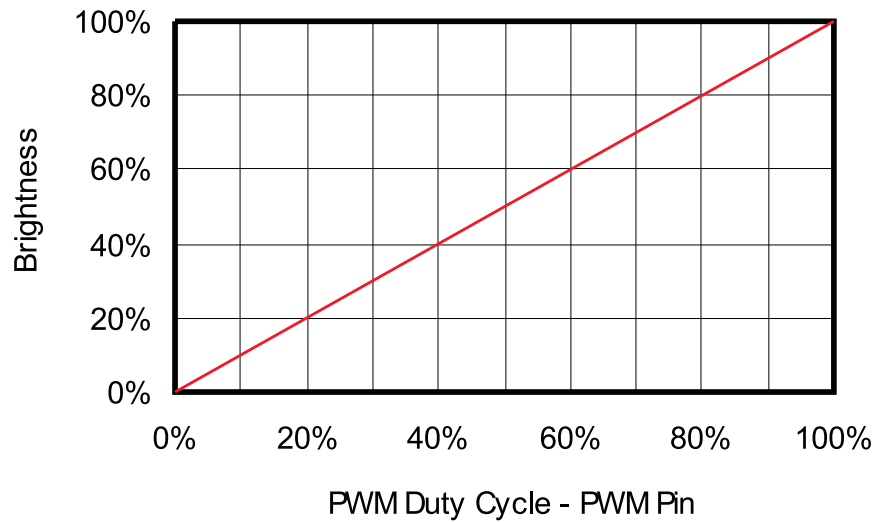

Figure 1



EXTERNAL PWM DIMMING



Graph 2

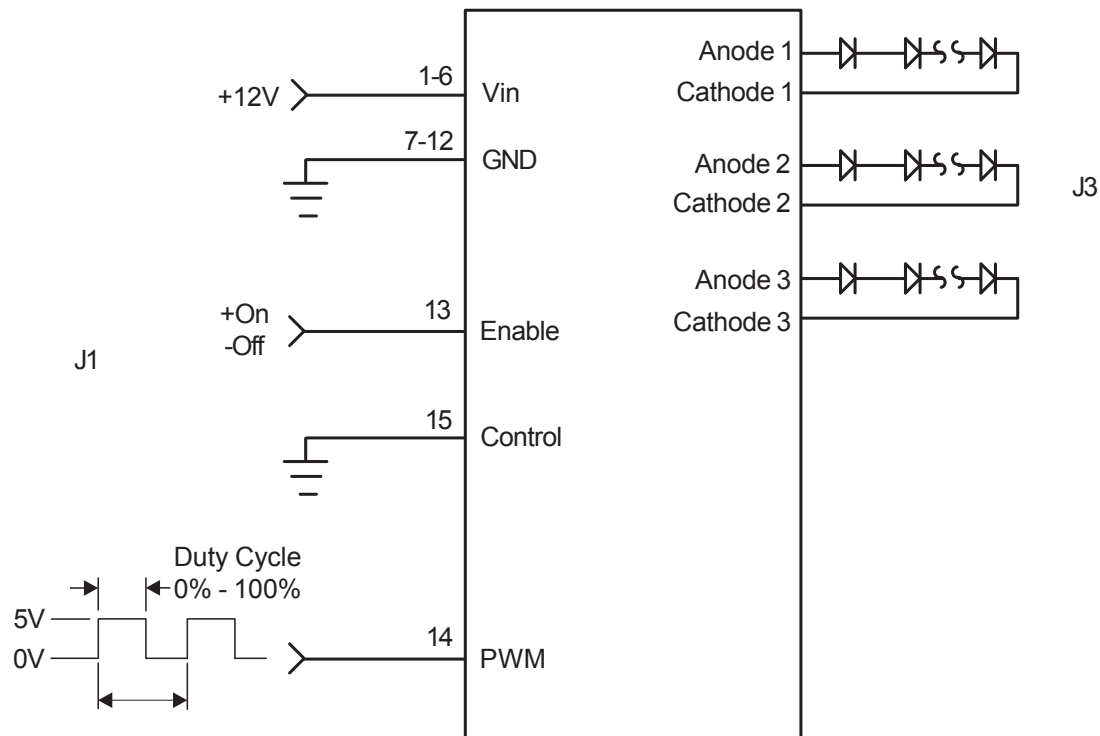

Figure 2



Endicott Research Group, Inc. (ERG) reserves the right to make changes in circuit design and/or specifications at any time without notice. Accordingly, the reader is cautioned to verify that data sheets are current before placing orders. Information furnished by ERG is believed to be accurate and reliable. However, no responsibility is assumed by ERG for its use.