



# L2479

## Specifications and Applications Information

04/05/11

**8m Class**  
Two Lamp  
DC to AC Inverter

The ERG L2479 (*8m Class*) low profile dc to ac inverter is specifically designed to power the LG Philips LB121S1-A2 display backlight to a moderate brightness level from a +12 volt dc source.

This low profile inverter features:

- ✓ Less Than 8 mm in Height
- ✓ LCD Module Specific
- ✓ Display Compatible Output Connector
- ✓ Firm Specifications
- ✓ Application Information
- ✓ Designed, Manufactured and Supported in the USA
- ✓ Custom Input and Output Voltages
- ✓ Flexible System Interface
- ✓ Notebook Display Head Compatible

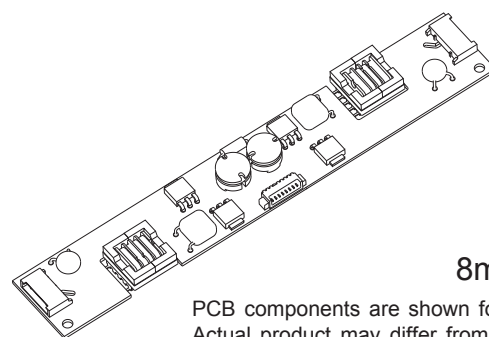

**8m Package**

PCB components are shown for reference only. Actual product may differ from that shown.

### Package Configuration

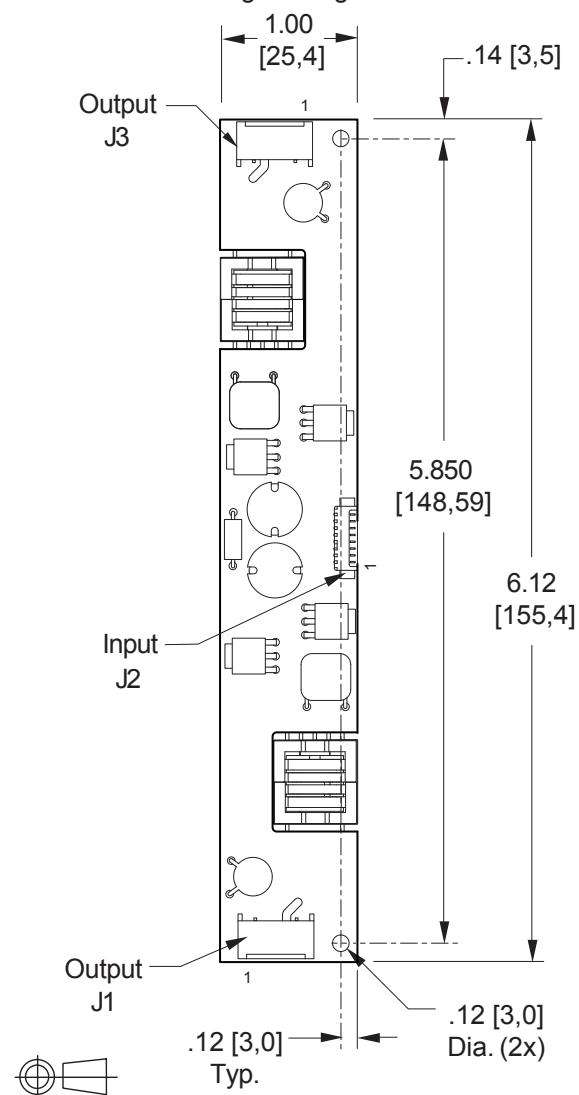

PCB components are shown for reference only. Actual product may differ from that shown.

### Connectors

Input Connector		Output Connectors	
Molex 53261-0871		JST SM02(8.0)B-BHS-1-TB	
J2-1,2	+Vin	J1-1	ACout
J2-3,4	GND	J1-2	ACreturn
J2-5	Enable	J3-1	ACout
J2-6,7,8	N/C	J3-2	ACreturn

**Absolute Maximum Ratings**

Rating	Symbol	Value	Units
Input Voltage Range	$V_{in}$	-0.3 to +13.2	Vdc
Storage Temperature	$T_{stg}$	-40 to +85	°C

**Operating Characteristics**

With a load simulating the referenced display and lamp warm-up of 5 minutes.  
Unless otherwise noted  $V_{in} = 12.00$  Volts dc and  $T_a = 25^\circ\text{C}$

Characteristic	Symbol	Min	Typ	Max	Units
Input Voltage	$V_{in}$	+10.8	+12.0	+12.6	Vdc
Component Surface Temperature (note 1)	$T_s$	-20	-	+80	°C
Input Current (note 2)	$I_{in}$	-	0.75	1.00	Adc
Operating Frequency	$F_o$	32	36	40	kHz
Minimum Output Voltage (note 3)	$V_{out}(\text{min})$	1500	-	-	Vrms
Efficiency	$\eta$	-	88	-	%
Output Current (per lamp)	$I_{out}$	-	6.0	-	mArms
Output Voltage	$V_{out}$	-	670	-	Vrms
Enable Pin Input Current Requirement (note 4)	$I_{Enable}$	-	25	-	mAdc

Specifications subject to change without notice.

(Note 1) Surface temperature must not exceed 80 degrees C; thermal management actions may be required.

(Note 2) Input current in excess of maximum may indicate a load/inverter mismatch condition, which can result in reduced reliability. Please contact ERG technical support.

(Note 3) Provided data is not tested but guaranteed by design.

(Note 4) Required User Enable/Disable Interface Circuit is shown on page 3.

**Application Notes:**

- 1) The minimum distance from high voltage areas of the inverter to any conductive material should be .12 inches per kilovolt of starting voltage.
- 2) Mounting hardware to be non-conductive.
- 3) Open framed inverters should not be used in applications at altitudes over 10,000 feet.
- 4) ACreturn should be left floating, not grounded.
- 5) Contact ERG for possible exceptions.



**Endicott Research Group, Inc.**

2601 Wayne St., Endicott, NY 13760

607-754-9187 Fax 607-754-9255

<http://www.ergpower.com>

Made in USA

## PWM Dimming

Circuit or equivalent required for proper inverter turnoff.

### Required User Enable/Disable Interface Circuit

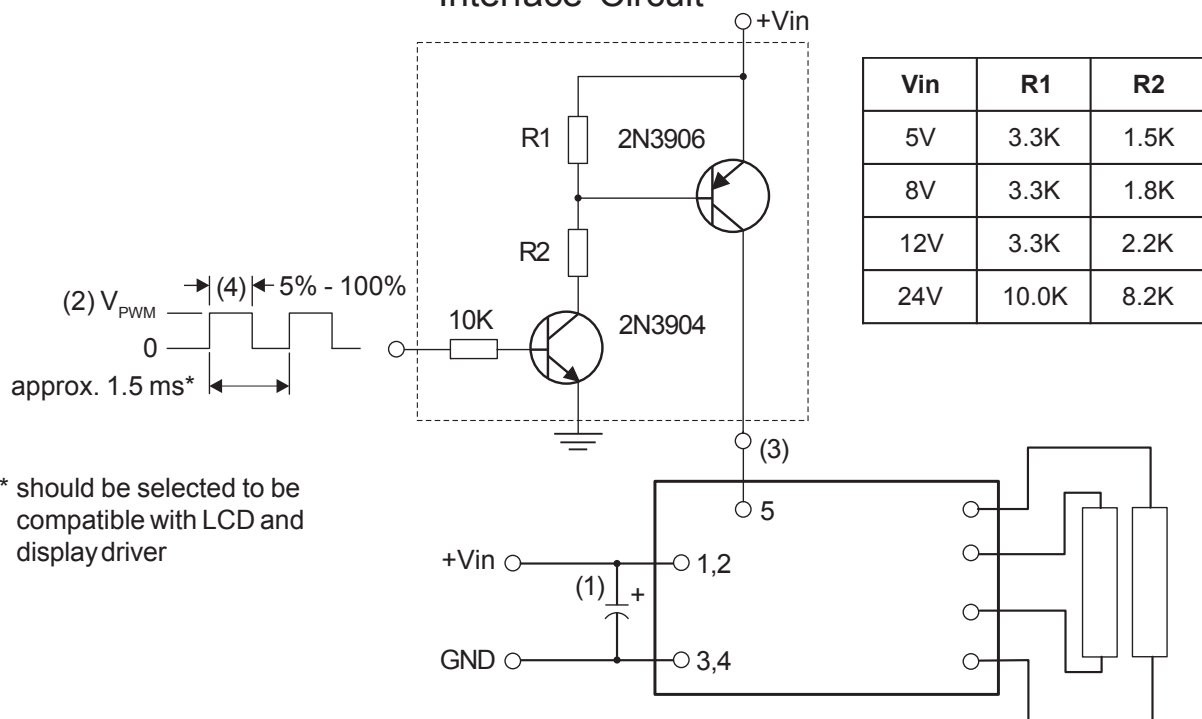

- (1) Low ESR type input by-pass capacitor (22  $\mu$ F - 100  $\mu$ F) may be required to reduce reflected ripple.
- (2)  $V_{P_{PWM}}$  from 2.4V to less than or equal to +Vin.
- (3) Full brightness without PWM control requires that pin 5 be tied to +Vin. Pin 5 must be at 0V to turn off.
- (4) Duty Cycle 5% - 100%.



Endicott Research Group, Inc. (ERG) reserves the right to make changes in circuit design and/or specifications at any time without notice. Accordingly, the reader is cautioned to verify that data sheets are current before placing orders. Information furnished by ERG is believed to be accurate and reliable. However, no responsibility is assumed by ERG for its use.