



Endicott Research Group, Inc.  
 2601 Wayne St., Endicott, NY 13760  
 607-754-9187 Fax 607-754-9255  
<http://www.ergpower.com>

# E1042

## Specifications and Applications Information

04/07/11

## Two Lamp DC to AC Inverter

The E1042 (E200II Series) dc to ac inverter is specifically designed to power the backlight of the Epson EG7500B-LS or EG7500F-LS LCD display to a moderate brightness level from a +12 Volt dc source.

The E1042's small size, encapsulated package and low input power requirements (typically 3.3 Watts), make it the ideal power source for applications where small size, high efficiency and reliability are critical.

This inverter is designed to satisfy the most common cold-cathode lighting requirements for the EG7500B-LS or EG7500F-LS displays. Custom units, providing different inputs, outputs or package refinements are available.

Made in U.S.A.

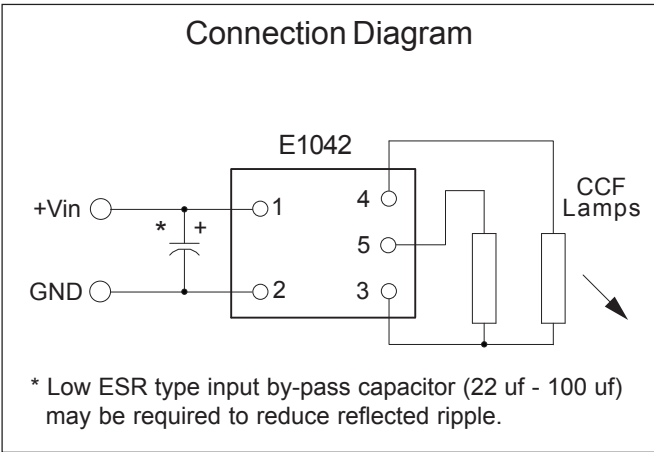
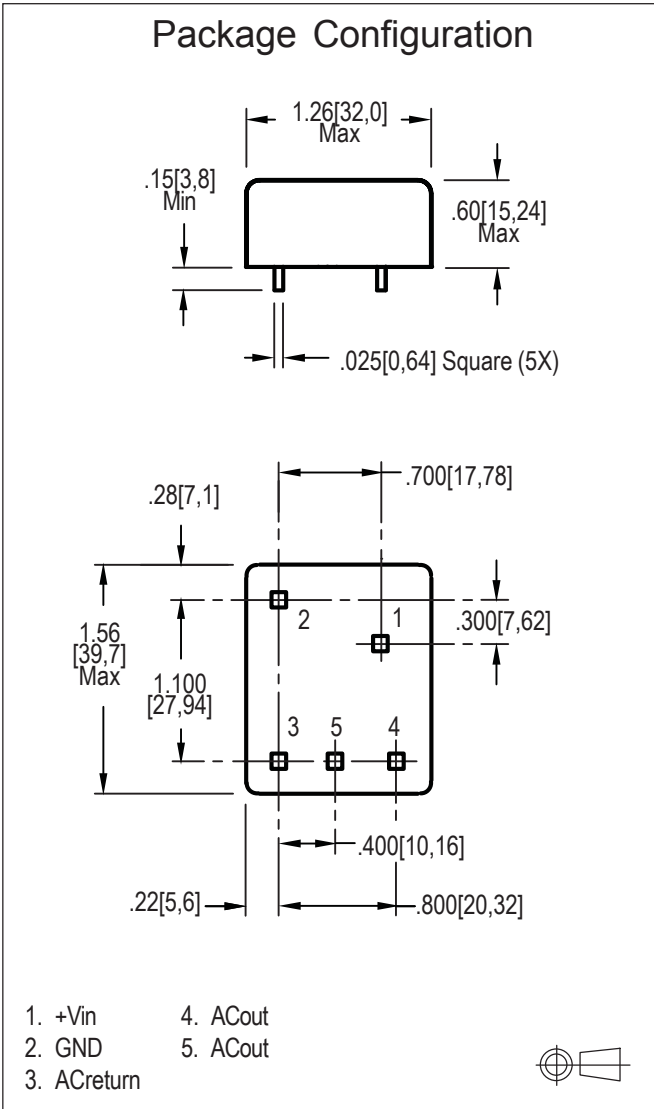
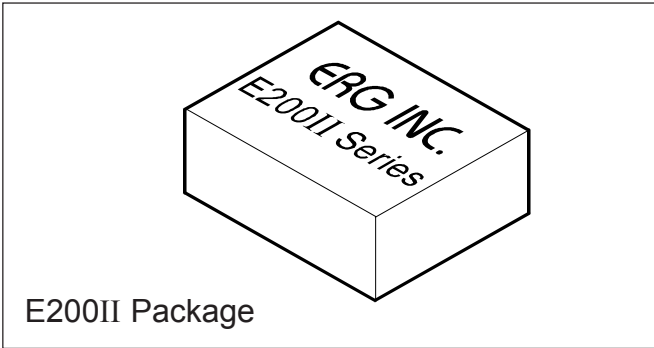



### Absolute Maximum Ratings

Rating	Symbol	Value	Units
Input Voltage Range	$V_{in}$	-0.3 to +13.2	Vdc
Storage Temperature	$T_{stg}$	-40 to +85	°C

### Operating Characteristics

With the referenced display and lamp warm-up of 5 minutes.  
 Unless otherwise noted  $V_{in}$  = 12.00 Volts dc and  $T_a$  = 25°C.

Characteristic	Symbol	Min	Typ	Max	Units
Input Voltage	$V_{in}$	+10.8	+12.0	+12.6	Vdc
Component surface Temperature (note 1)	$T_s$	-20	-	+80	°C
Input Current (note 2)	$I_{in}$	-	0.28	0.32	Adc
Operating Frequency	$F_o$	20	24	30	kHz
Minimum Output Voltage (note 3)	$V_{out}$ (min)	1060	-	-	Vrms
Efficiency	$\eta$	-	83	-	%
Output Current (per lamp)	$I_{out}$	-	4.0	-	mArms
Output Voltage	$V_{out}$	-	300	-	Vrms

Specifications subject to change without notice.

(Note 1) Surface temperature must not exceed 80 degrees C; thermal management actions may be required.

(Note 2) Input current in excess of maximum may indicate a load/inverter mismatch condition, which can result in reduced reliability. Please contact ERG technical support.

(Note 3) Provided data is not tested but guaranteed by design.

### Application Notes:

- 1) Printed circuit boards to be free of traces beneath the inverter.
- 2) The minimum distance from high voltage areas of the inverter to any conductive material should be .12 inches per kilovolt of starting voltage.
- 3) ACreturn should be left floating, not grounded.
- 4) Contact ERG for possible exceptions.



Endicott Research Group, Inc. (ERG) reserves the right to make changes in circuit design and/or specifications at any time without notice. Accordingly, the reader is cautioned to verify that data sheets are current before placing orders. Information furnished by ERG is believed to be accurate and reliable. However, no responsibility is assumed by ERG for its use.