

D Series



12 Volt Input Dc to Ac Inverter

DMD60J4

The DMD60J4 is a generic dc to ac inverter designed to generate 6 mArms into a 650 - 750 volt load (CCFL) from a nominal 12 volt dc source.

FEATURES

- Low Profile
- Display compatible connector
- High efficiency

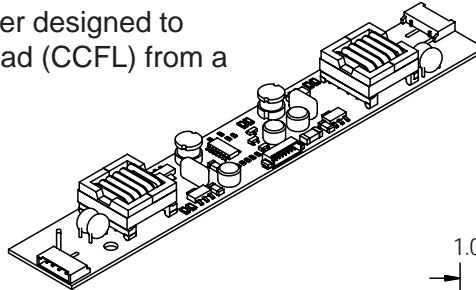

PHYSICAL SPECIFICATIONS

- Size: 1.03" x 6.69" x .51"
(without input connector) (26,2mm x 170mm x 13mm)
- Weight: 45 grams
- Component Surface Temperature: -20° to +80°C
- Storage Temperature: -40° to +85°C
- Humidity: 95% RH Max

Characteristics	Value	Units	Note(s)
Input Voltage	10.8 - 12.6	Vdc	
Input Current	1.7 typ	Adc	$R_L = 117 \text{ k}\Omega(4x)$
Minimum No Load Output Voltage	1500	Vrms	$V_{in} = 12.00 \text{ Vdc}$
Frequency	39 typ	kHz	$V_{in} = 12.00 \text{ Vdc}$
Output Current	6.1	mArms	$R_L = 117 \text{ k}\Omega$
Efficiency	84	%	Typical
The maximum input current (which indicates an overload condition) is 2.0 Adc maximum.			

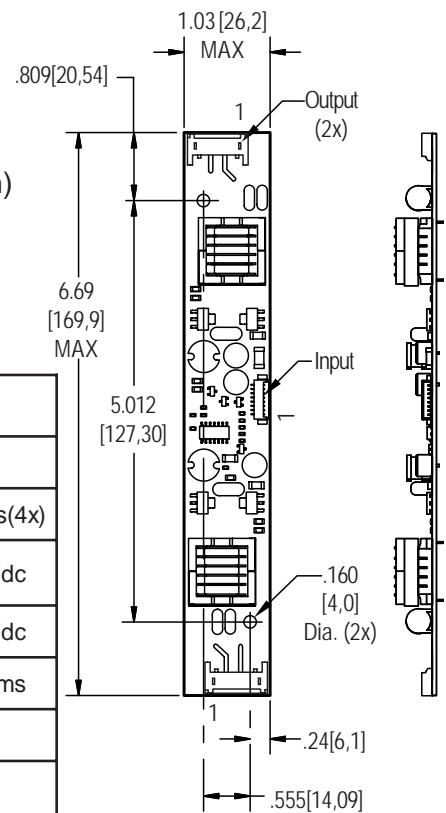

PCB components are shown for reference only. Actual product may differ from that shown.

Input Connector: Molex 53261-0871
Output Connectors: JST SM04(4.0)B-BHS-1-TB

Inverters specifically designed to match most popular LCD modules are also available. Contact your authorized distributor or ERG direct.

Endicott Research Group, Inc.

2601 Wayne St., Endicott, NY 13760
607-754-9187 Fax 607-754-9255
<http://www.ergpower.com>

Pin Descriptions

J2-1 ACout	J1-1 +Vin	J3-1 ACout
J2-2 ACout	J1-2 +Vin	J3-2 ACout
J2-3 ACreturn	J1-3 GND	J3-3 ACreturn
J2-4 ACreturn	J1-4 GND	J3-4 ACreturn
	J1-5 Enable	
	J1-6 Control	
	J1-7 GND	
	J1-8 GND	

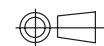

Onboard PWM

Unless otherwise noted $V_{in} = 12.00$ Volts DC, $T_a = 25$ °C and unit has been running for 5 minutes.

Characteristic	Symbol	Min	Typ	Max	Units
Frequency	f_{pwm}	-	160	-	Hz
Control Input Bias Current	I_{cbias}	-	-	10	μA

Pin Descriptions

- Vin** Input voltage to the inverter. The two pins should be connected for optimum reliability and efficiency.
- GND** Inverter ground. The four pins should be connected for optimum reliability and efficiency.
- Control** Analog voltage input to the onboard pulse width modulator. Decreasing this voltage increases the ON time of the onboard PWM resulting in increased brightness. The inverter is full ON when this voltage is near inverter ground.
- Enable** Inverter Enable. Pull this pin low to disable inverter operation. This pin must be high to enable the inverter. The onboard PWM is always utilized.

Application information

The DMD series of inverters is designed to power up to four cold cathode fluorescent lamps. An external analog control interfaces with an onboard pulse width modulator to provide dimming control. The DMD inverter can reliably dim to less than 5% duty cycle.

External shutdown of the inverter is accomplished using the Enable pin. Pulling this pin low (below V_{thoff} , 1V to GND) disables the inverter. Enabling the inverter is accomplished by pulling this pin high (above V_{thon} , 2.5V to 13.2V). The input impedance to V_{in} is typically 10kOhm.

If analog voltage dimming is required, the analog voltage is applied to the Control pin. Figure 1 shows how to connect the inverter for onboard PWM operation. Graph 1 shows the relationship of PWM duty cycle to input control voltage.

If an external PWM is used, simply connect the Enable pin to the PWM source and connect the Control pin to inverter Ground. If the onboard PWM is used, connect the analog voltage to the Control pin.



Endicott Research Group, Inc.
 2601 Wayne St., Endicott, NY 13760
 607-754-9187 Fax 607-754-9255
<http://www.ergpower.com>



Connection and Application Information

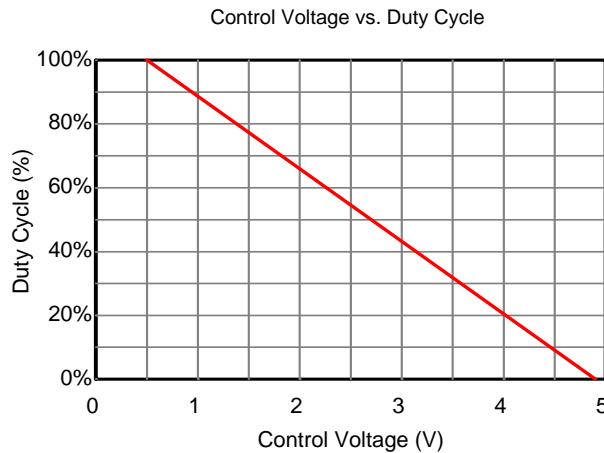

Graph 1

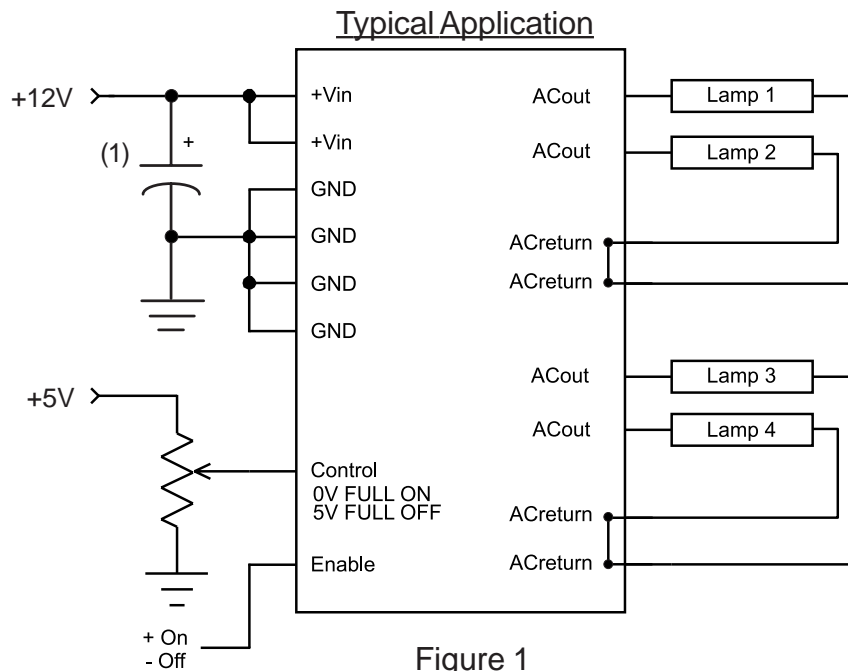

Figure 1

- (1) Low ESR type input by-pass capacitor (22 μ F - 220 μ F) may be required to reduce reflected ripple, and to improve power supply transient response.