



Endicott Research Group, Inc.  
 2601 Wayne St., Endicott, NY 13760  
 607-754-9187 Fax 607-754-9255  
<http://www.ergpower.com>

# DMAD3224F



## Specifications and Applications Information

11/30/06

Preliminary

The ERG DMAD3224F (DMA Series) DC to AC inverter features onboard connectors and can be easily dimmed using the onboard PWM Dimming or an external PWM generator.

Powered by a regulated +12 Volt DC source, the DMAD3224F is designed to power the backlight of the Optrex T-51863D150J-FW-A-AA.

### Product Features

- ✓ Small Package Size, less than 14mm in height.
- ✓ High Dimming Ratio
- ✓ High Efficiency
- ✓ Made in U.S.A.

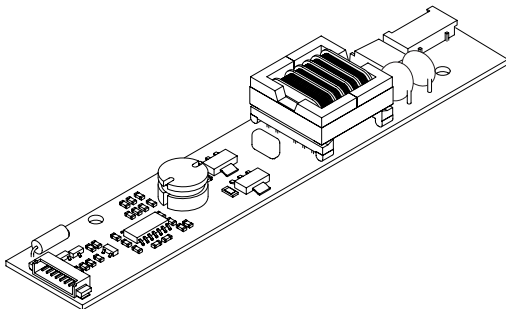

PCB components are shown for reference only.  
 Actual product may differ from that shown.

DMAD Package

## Two Lamp DC to AC Inverter

### Package Configuration

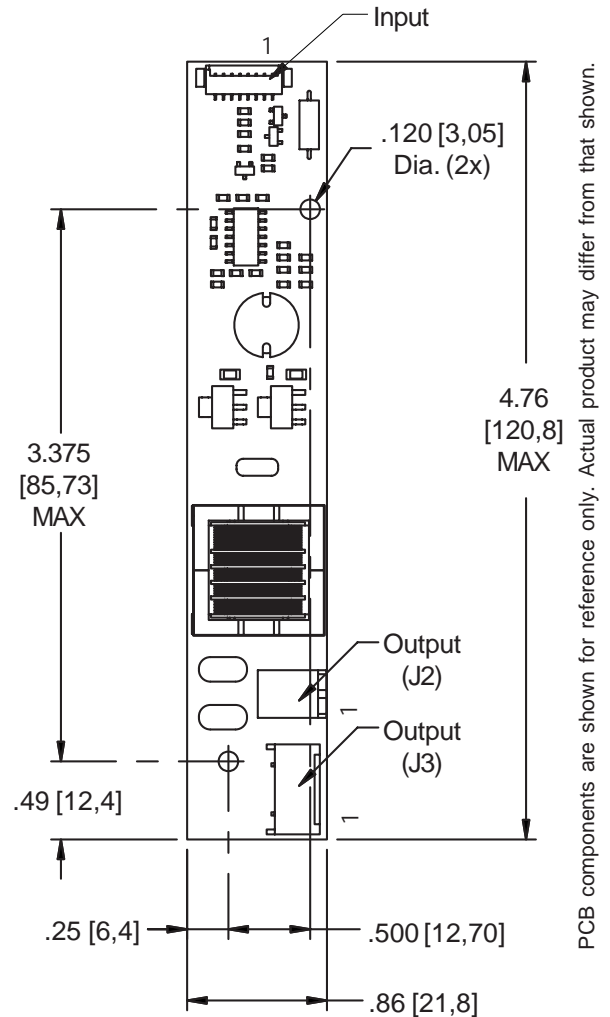

Mass: 45 grams



### Connectors

J2 Output JST SM02B-BHSS-1-TB	Input Molex 53261-0871
J3 Output JST SM02(4.0)B-BHS-1-TB	

### Pin Descriptions

J2-1 ACout	J1-1 Vin	J3-1 ACcommon
J2-2 ACout	J1-2 Vin	J3-2 ACcommon
	J1-3 GND	
	J1-4 GND	
	J1-5 Enable	
	J1-6 Control	
	J1-7 N/C	
	J1-8 N/C	

**Absolute Maximum Ratings**

Rating	Symbol	Value	Units
Input Voltage Range	$V_{in}$	-0.3 to +13.2	Vdc
Storage Temperature	$T_{stg}$	-40 to +85	°C

**Operating Characteristics**

With a load simulating the referenced display and lamp warm-up of 5 minutes.  
Unless otherwise noted  $V_{in} = 12.00$  Volts dc and  $T_a = 25^{\circ}\text{C}$ .

Characteristic	Symbol	Min	Typ	Max	Units
Input Voltage	$V_{in}$	+10.8	+12.0	+12.6	Vdc
Component Surface Temperature	$T_s$	-20		+80	°C
Input Current (Note 1)	$I_{in}$	-	0.77	0.88	Adc
Operating Frequency	$F_o$	33	38	43	kHz
Minimum Output Voltage	$V_{out}$ (min)	1600	-	-	Vrms
Efficiency	$\eta$	-	90	-	%
Output Current (per lamp)	$I_{out}$	-	6.7	-	mArms
Output Voltage	$V_{out}$	-	620	-	Vrms
<b>Enable Pin</b>					
Turn-off Threshold	$V_{thoff}$	GND	-	0.8	Vdc
Turn-on Threshold	$V_{thon}$	2.0	10.0	$V_{in}$	Vdc

Specifications subject to change without notice.

**(Note 1)** Input current in excess of maximum may indicate a load/inverter mismatch condition, which can result in reduced reliability. Please contact ERG technical support.

**Application Notes:**

- 1) The minimum distance from high voltage areas of the inverter to any conductive material should be .12 inches per kilovolt of starting voltage.
- 2) Mounting hardware should be non-conductive.
- 3) Open framed inverters should not be used in applications at altitudes over 10,000 feet.
- 4) Contact ERG for possible exceptions.



## Onboard PWM

Unless otherwise noted  $V_{in} = 12.00$  Volts DC,  $T_a = 25$  °C and unit has been running for 5 minutes.

Characteristic	Symbol	Min	Typ	Max	Units
Frequency	$f_{pwm}$	-	160	-	Hz
Control Input Bias Current	$I_{cbias}$	-	-	10	$\mu A$

## Pin Descriptions

- Vin** Input voltage to the inverter. The two pins should be connected for optimum reliability and efficiency.
- GND** Inverter ground. The two pins should be connected for optimum reliability and efficiency.
- Control** Analog voltage input to the onboard pulse width modulator. Decreasing this voltage increases the ON time of the onboard PWM resulting in increased brightness. The inverter is full ON when this voltage is near inverter ground.
- Enable** Inverter Enable. Pull this pin low to disable inverter operation. This pin must be high to enable the inverter. The onboard PWM is always utilized.

## Application information

The DMAD series of inverters is designed to power up to two cold cathode fluorescent lamps. An external analog control interfaces with an onboard pulse width modulator to provide dimming control. The DMAD inverter can reliably dim to less than 5% duty cycle.

External shutdown of the inverter is accomplished using the Enable pin. Pulling this pin low (below  $V_{thoff}$ ) disables the inverter. Enabling the inverter is accomplished by pulling this pin high (above  $V_{thon}$ ).

If analog voltage dimming is required, the analog voltage is applied to the Control pin. Figure 1 shows how to connect the inverter for onboard PWM operation. Graph 1 shows the relationship of PWM duty cycle to input control voltage.

If an external PWM is used, simply connect the Enable pin to the PWM source and connect the Control pin to inverter Ground. If the onboard PWM is used, connect the analog voltage to the Control pin.

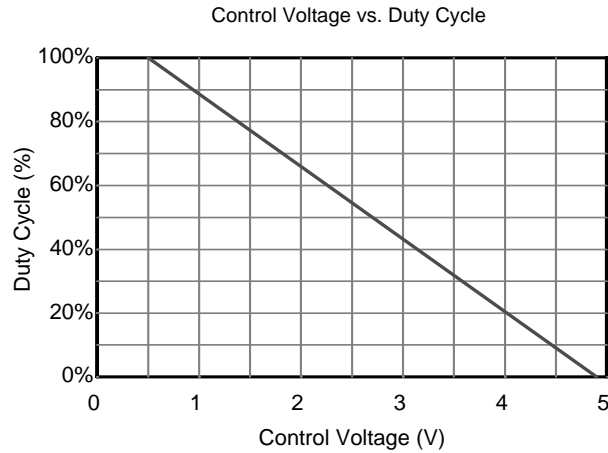

Graph 1

### Typical Application

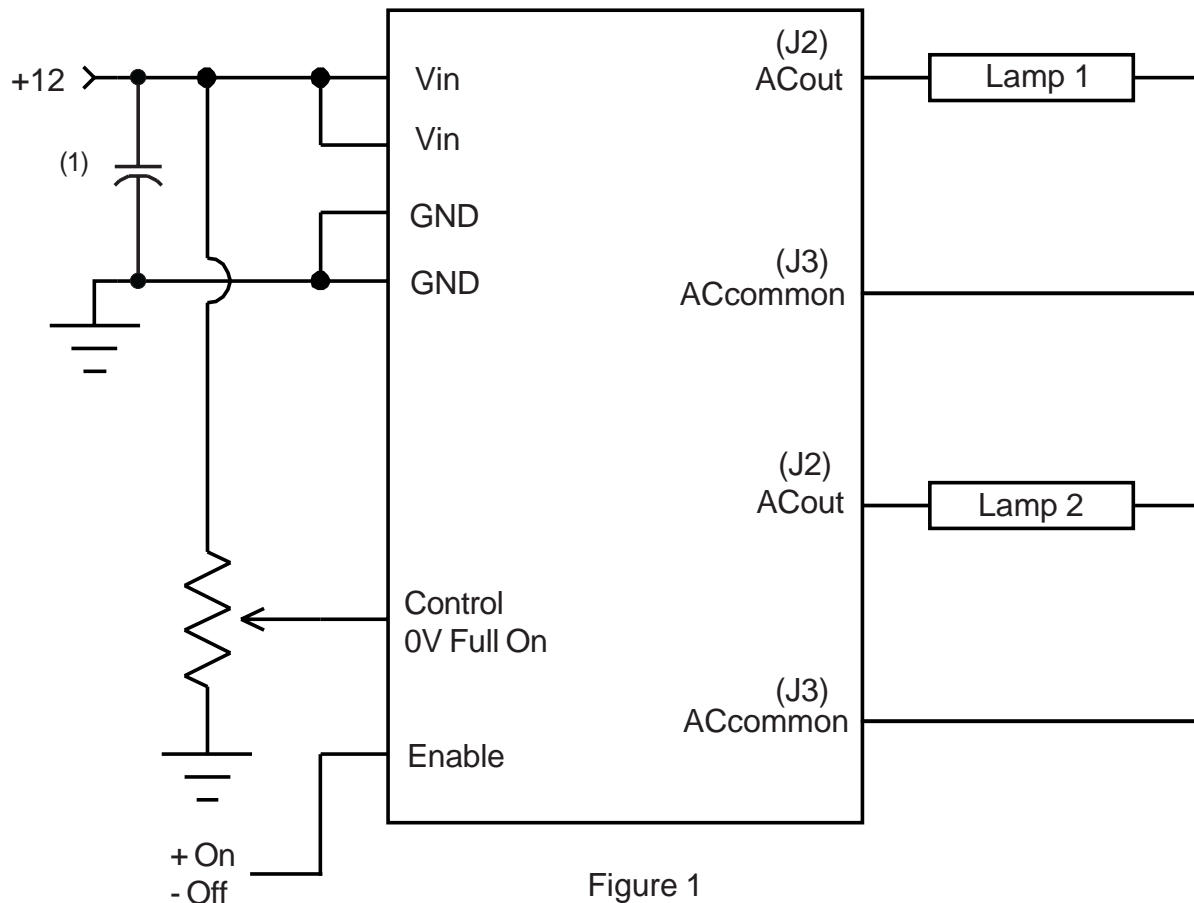

Figure 1

Note 1 - Low ESR type input by-pass capacitor (22 uf - 100 uf) may be required to reduce reflected ripple.



Endicott Research Group, Inc. (ERG) reserves the right to make changes in circuit design and/or specifications at any time without notice. Accordingly, the reader is cautioned to verify that data sheets are current before placing orders. Information furnished by ERG is believed to be accurate and reliable. However, no responsibility is assumed by ERG for its use.