



Endicott Research Group, Inc.

2601 Wayne St., Endicott, NY 13760
 607-754-9187 Fax 607-754-9255
<http://www.ergpower.com>

DMA13151

Specifications and Applications Information

06/25/04

Preliminary

One Tube
 DC to AC Inverter

The ERG DMA13151 (DMA Series) DC to AC inverter features onboard connectors and can be easily dimmed using an external pulse-width modulated control signal. This unit is less than 13mm in height and the two mounting holes makes installation very straight forward.

Powered by a regulated +12 volt DC source the DMA13151 is specially designed to power the Sharp LQ065Y5DG01 backlight.

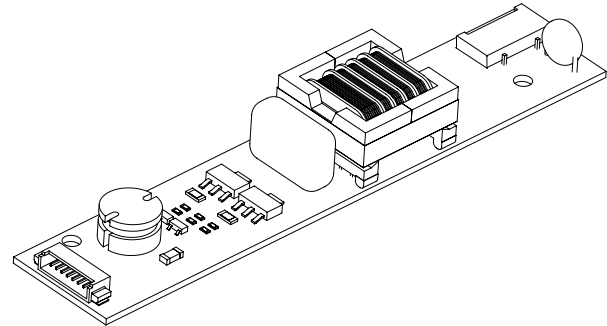

DMA Package

Product Features

- ✓ Small Package Size, less than 13mm in height.
- ✓ High Efficiency
- ✓ Made in U.S.A.

Package Configuration

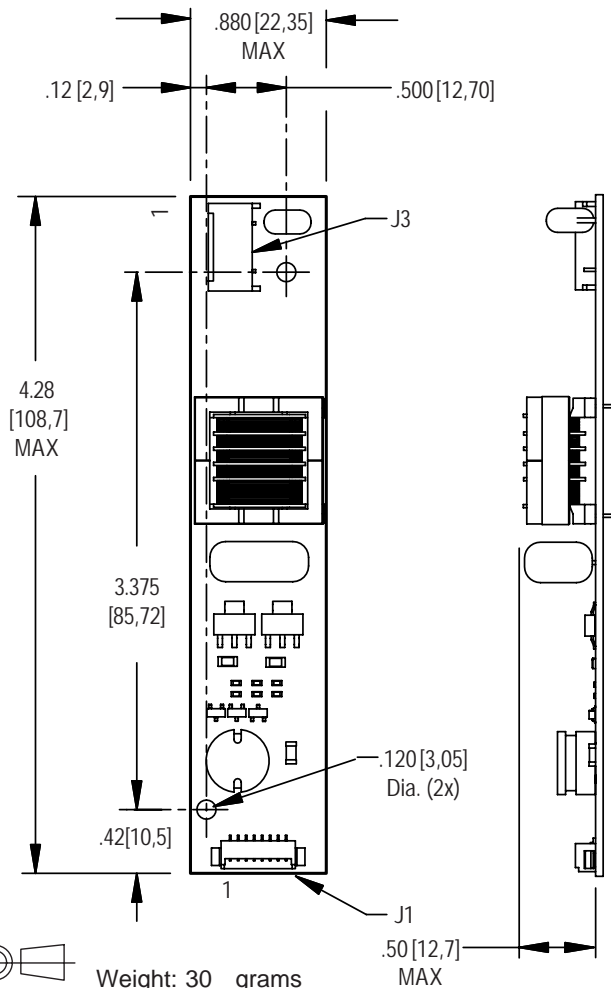

Connectors

J1 - (Input)
 MOLEX
 532-61-0890

J3 - (Output)
 JST
 SM02(8.0)B-BHS-1-TB

Pinouts

J1-1 V_{in}
 J1-2 V_{in}
 J1-3 GND
 J1-4 GND
 J1-5 Enable
 J1-6 N/C
 J1-7 N/C
 J1-8 N/C

J2-1 N/A
 J2-2 N/A

 J3-1 AC_{out}
 J3-2 AC_{com}



Absolute Maximum Ratings ^(Note 1)

Rating	Symbol	Value	Units
Input Voltage	V_{in}	-0.3 to +15	Vdc
Enable	V_{Enable}	-0.3 to +15	Vdc
Operating Temperature	T_a	-0 to +85	°C
Storage Temperature	T_s	-40 to +85	°C

Recommended Operating Conditions

Rating	Symbol	Value	Units
Input Voltage	V_{in}	10.8 to 12.6	Vdc
Operating Temperature ^(Note 2)	T_a	0 to +50	°C

Electrical Characteristics

Unless otherwise noted $V_{in} = 12.00$ Volts dc and $T_a = 25^\circ\text{C}$

Characteristic	Symbol	Min	Typ	Max	Units
Input Current	I_{in}	-	.43	.50	A_{DC}
Input Ripple Current	I_{rip}	-	-	-	mA_{pk-pk}
Operating Frequency	F_o	27	32	37	KHz
Efficiency	η	-	79	-	%
Output Voltage (no load) ^(Note 3)	V_{start}	1800	-	-	V
Output Voltage (with lamp)	V_{out}	-	710	-	V
Output Current (per tube)	I_{out}	-	5	-	mA_{rms}
Enable (pin J1-5)					
Turn-Off Threshold	V_{thoff}	-	-	0.7	V
Turn-On Threshold	V_{thon}	2.0	-	-	V

(Note 1) Reliable and predictable operation of the device are not guaranteed with applied stresses at or beyond those listed in "Absolute Maximum Ratings". Operation at these limits may reduce device reliability and is therefore not recommended. Please refer to "Recommended Operating Conditions" for reliable operation of the device.

(Note 2) Operation above 50°C is possible if airflow is provided.

(Note 3) Provided data is not tested but guaranteed by design.

Application Notes:

- 1) The minimum distance from high voltage areas of the inverter to any conductive material should be .12 inches per kilovolt of starting voltage.
- 2) Mounting hardware should be non-conductive.
- 3) Open framed inverters should not be used in applications at altitudes over 10,000 feet.
- 4) Contact ERG for possible exceptions.