

D Series



12 Volt Input Dc to Ac Inverter

D128D60J

The D128D60J is a generic dc to ac inverter designed to generate 6 marms into a 350 - 550 volt load (CCFT) from a nominal 12 volt dc source. It can be easily dimmed using an external analog control signal.

FEATURES

- Low Profile
- Display compatible connector
- High efficiency

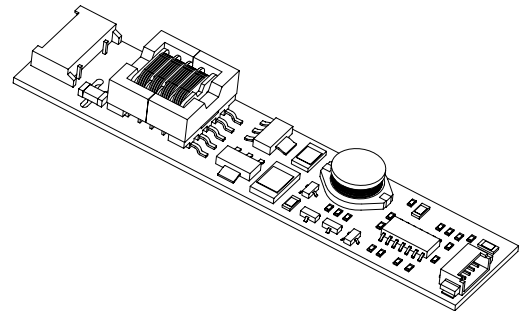

PHYSICAL SPECIFICATIONS

- Size: .75" x 3.43" x .32"
 (without input connector) (19,0mm x 87,1mm x 8mm)
- Weight: 15 grams
- Operating Temperature: 0° to +70°C
- Storage Temperature: -20° to +85°C
- Humidity: 95% RH Max

Characteristics	Value	Units	Note(s)
Input Voltage	10.8 - 13.2	Volts dc	
Input Current	.30 typ	Adc	$R_L = 75 \text{ Kohms}$
Minimum No Load Output Voltage	1400	Vrms	$V_{in} = 12.00 \text{ Vdc}$
Frequency	41 typ	Khz	$V_{in} = 12.00 \text{ Vdc}$
Output Current	6.0	marms	$R_L = 75 \text{ Kohms}$
Efficiency	75	%	Typical
The maximum input current (which indicates an overload condition) is 1.0 Adc maximum			

Input Connector: Molex 53261-0590
 Output Connector: JST SM02(8.0)B-BHS-1-TB

Inverters specifically designed to match most popular LCD modules are also available. Contact your authorized distributor or ERG direct.

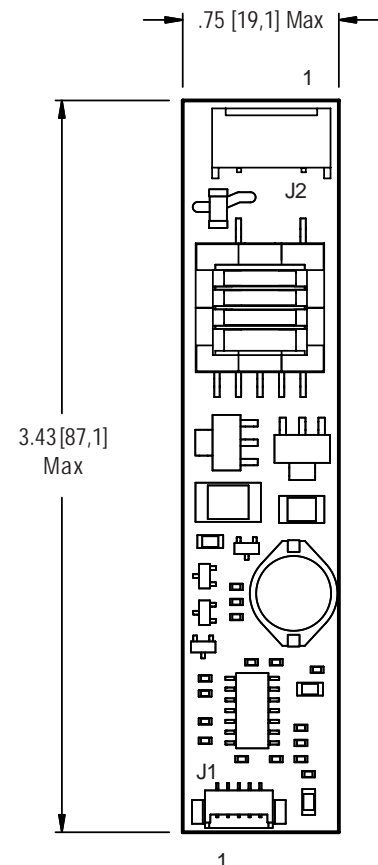

Pin Designation	
J1-1 Vin(+)	J2-1 ACout
J1-2 Vin(-)	J2-2 N/C
J1-3 Enable	J2-3 ACout
J1-4 Control	
J1-5 N/C	

Endicott Research Group, Inc.
 2601 Wayne Street Endicott, New York 13760
 607-754-9187 fax 607-754-9255
<http://www.ergpower.com>

Connection and Application Information

12 Volt Input Dc to Ac Inverter

D128D60J

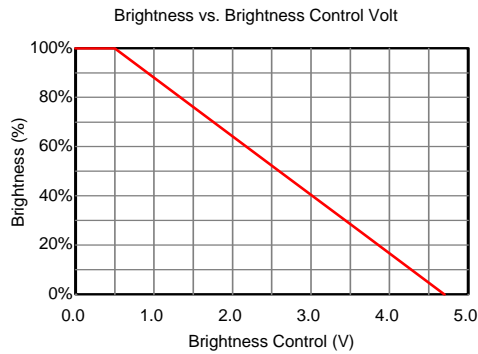
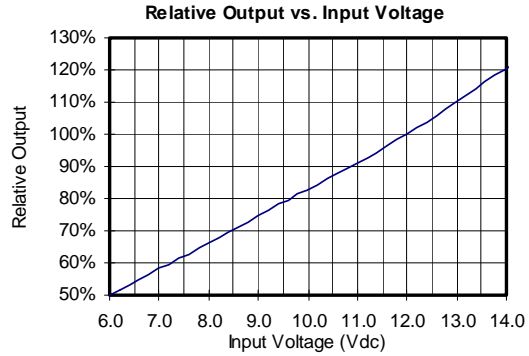
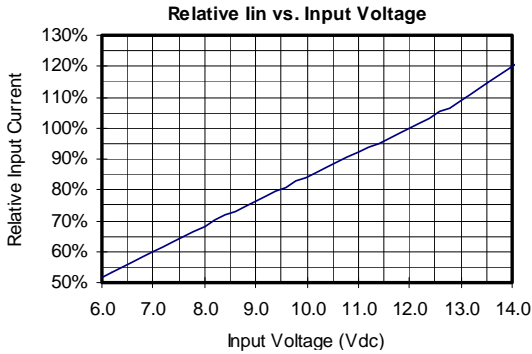

Typical Application

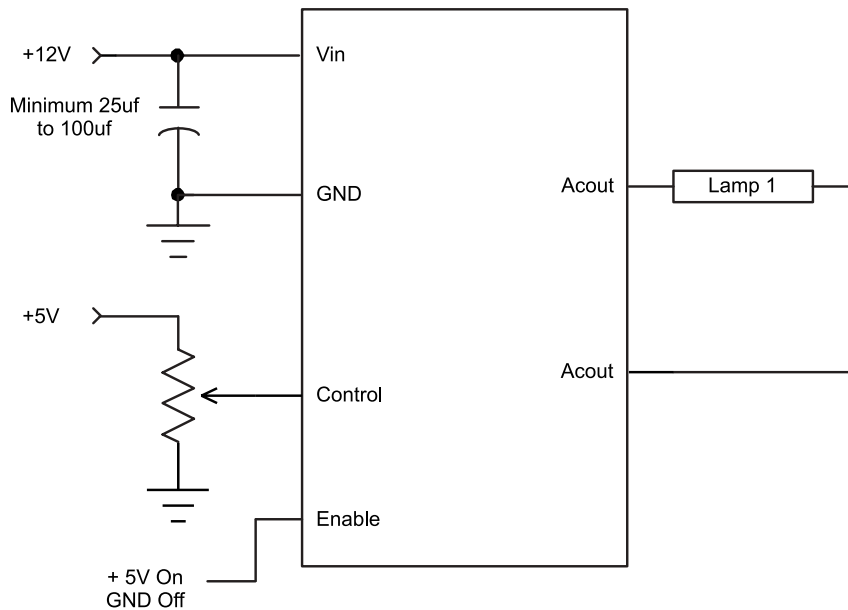

Endicott Research
Group, Inc.

Specifications are subject to change without notice.

03/26/02

D Series