

# D Series



## 5 Volt Input Dc to Ac Inverter

## D05M50M

The D05M50M is a generic dc to ac inverter designed to generate 5 mArms into a 270 - 370 Volt load (CCFL) from a nominal 5 volt dc source.

### FEATURES

- Low Profile
- Display compatible connector
- High efficiency

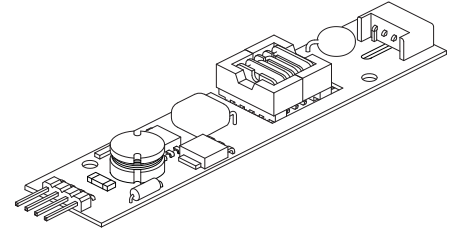

### PHYSICAL SPECIFICATIONS

Size:	.79" x 3.58" x .32"
(without input connector)	(20,1mm x 90,9mm x 8mm)
Weight:	11.4 grams
Component Surface Temperature:	-20° to +80°C
Storage Temperature:	-20° to +85°C
Humidity:	95% RH Max

Characteristics	Value	Units	Note(s)
Input Voltage	4.5 - 5.25	Vdc	
Input Current	0.46 typ	Adc	$R_L = 64 \text{ kOhms}$
Minimum No Load Output Voltage	1100	Vrms	$V_{in} = 5.0 \text{ Vdc}$
Frequency	36 typ	KHz	$V_{in} = 5.0 \text{ Vdc}$
Output Current	5.0	mArms	$R_L = 64 \text{ kOhms}$
Efficiency	75	%	Typical
Enable Pin Input Current	12 typ	mAdc	$V_{in} = 5.0 \text{ Vdc}$
The maximum input current (which indicates an overload condition) is 0.55 Adc maximum			

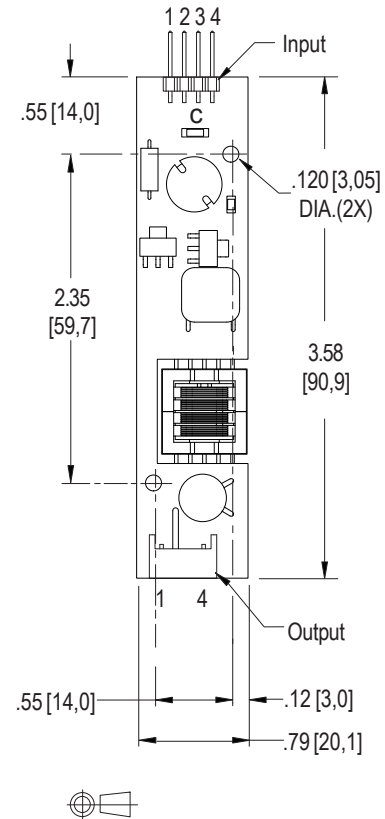

PCB components are shown for reference only. Actual product may differ from that shown.

Inverters specifically designed to match most popular LCD modules are also available. Contact your authorized distributor or ERG direct.

### Pin Descriptions

<u>Input Connector</u>	<u>Output Connectors</u>
4 position right angle header (.025" square, .100" centers)	Mitsumi M60-04-30-134P
J1-1 +Vin J1-2 GND J1-3 Enable * J1-4 N/C	J2-1 ACreturn J2-2 N/C J2-3 N/C J2-4 ACout
* Valid only with the "C" jumper removed	

## Endicott Research Group, Inc.

2601 Wayne St., Endicott, NY 13760  
607-754-9187 Fax 607-754-9255  
<http://www.ergpower.com>

# Connection and Application Information

## 5 Volt Input Dc to Ac Inverter

## D05M50M

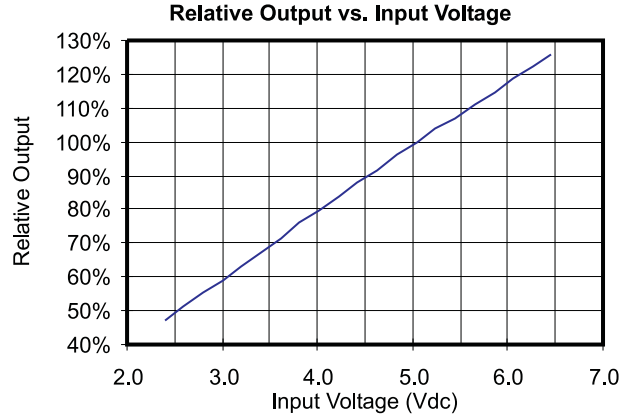
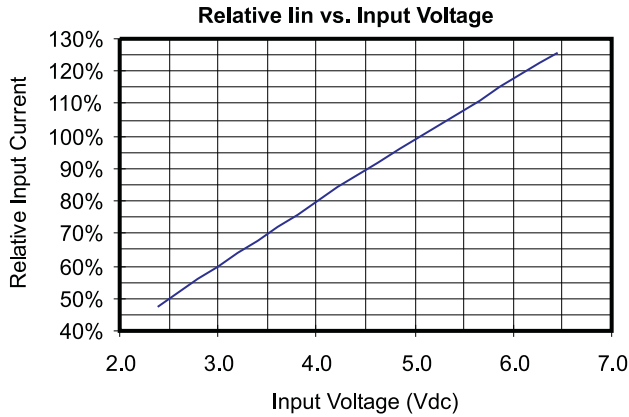

### PWM Dimming Required User Enable/Disable Interface Circuit (Valid only with JP1 removed)

With JP1 in place, a ground applied to the enable pin J1-3 will open the inverter fuse.

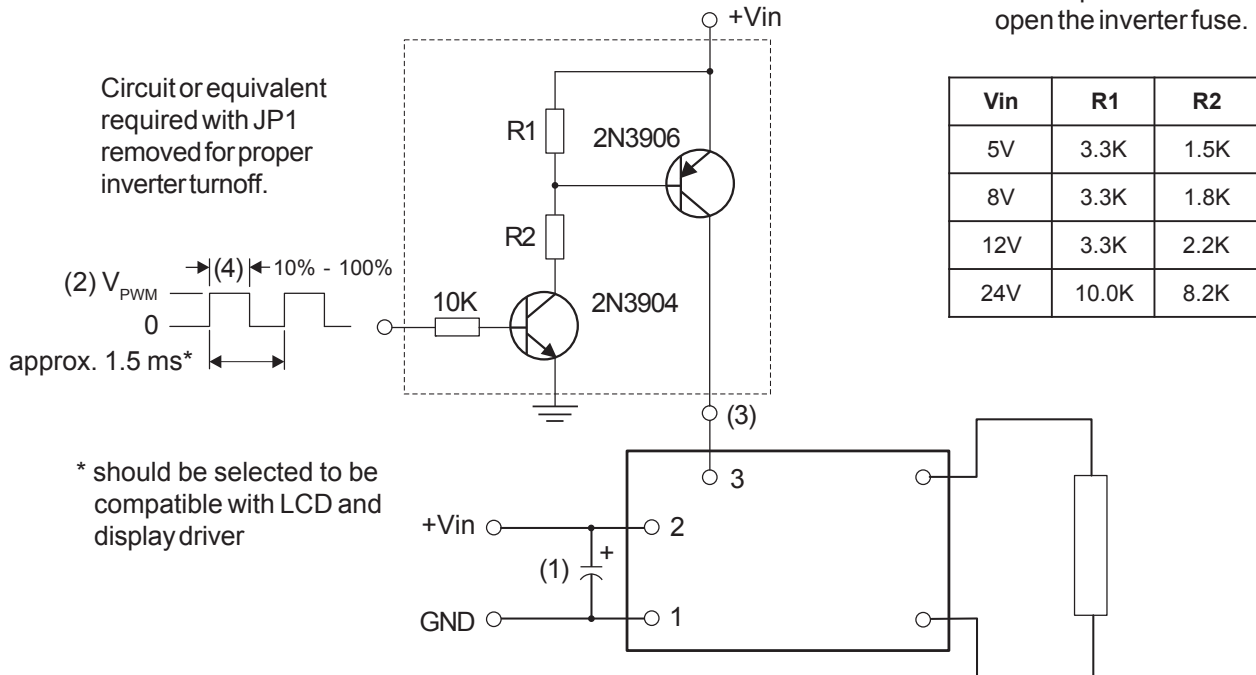

- (1) Low ESR type input by-pass capacitor (22 uf - 100 uf) may be required to reduce reflected ripple.
- (2)  $V_{PWM}$  from 2.4V to less than or equal to +Vin.
- (3) Full brightness without PWM control requires that pin 3 be tied to +Vin. Pin 3 must be at 0V to turn off.
- (4) Duty Cycle 10% - 100%.



Endicott Research Group, Inc.

2601 Wayne St., Endicott, NY 13760  
607-754-9187 Fax 607-754-9255  
<http://www.ergpower.com>

Specifications are subject to change without notice. 04/18/11

