



Endicott Research Group, Inc.

2601 Wayne St., Endicott, NY 13760

607-754-9187 Fax 607-754-9255

http://www.ergpower.com

Specifications and Applications Information

01/26/11

The ERG 8mD3428 (*8mD Series*) DC to AC inverter features onboard connectors and can be easily dimmed using an external analog control signal or external PWM generator.

Powered by a regulated +5 Volt DC source, the 8mD3428 is designed to power the LG Philips LB040Q02 display backlight.

Product Features

- ✓ Small Package Size, less than 9mm in height
- ✓ High Dimming Ratio
- ✓ High Efficiency
- ✓ Made in U.S.A.

This unit complements our 8m Series of DC to AC Inverters

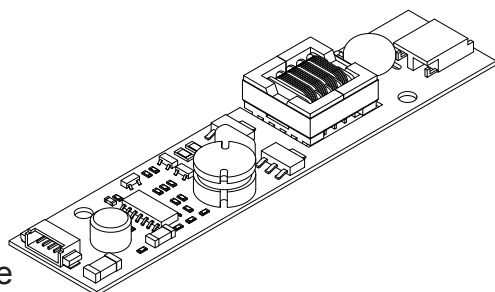

8mD Package

PCB components are shown for reference only. Actual product may differ from that shown.

Connectors

J1
Molex
53261-0571

J2
JST
SM02B-BHSS-1-TB

8mD3428

Single Lamp
DC to AC Inverter

Package Configuration

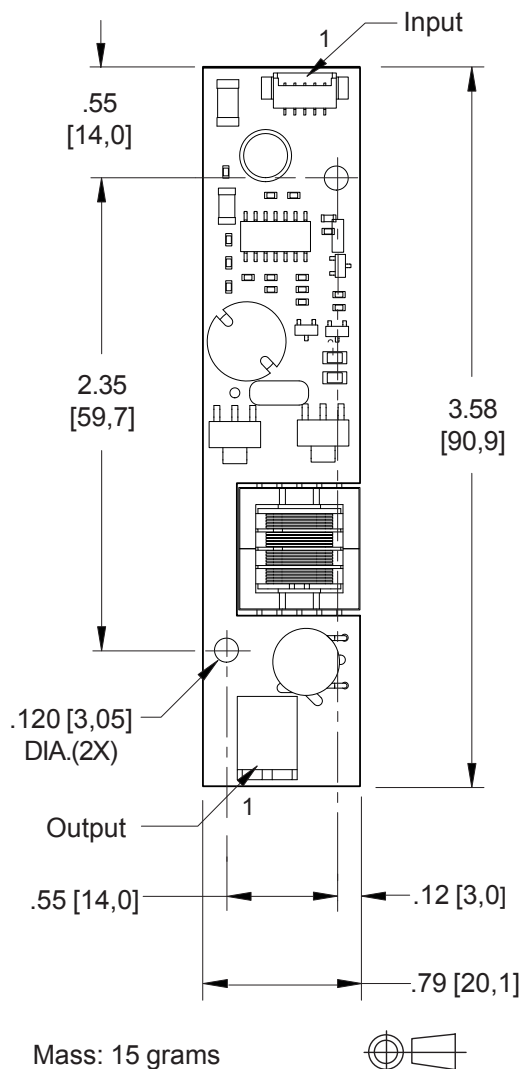

PCB components are shown for reference only. Actual product may differ from that shown.

Pin Descriptions

J1-1 +Vin
J1-2 GND
J1-3 Enable
J1-4 Control
J1-5 N/C

J2-1 ACout
J2-2 ACreturn

**Absolute Maximum Ratings**

Rating	Symbol	Value	Units
Input Voltage Range	V_{in}	-0.3 to +5.5	Vdc
Storage Temperature	T_{stg}	-40 to +85	°C

Operating Characteristics

With a load simulating the referenced display and lamp warm-up of 5 minutes.
Unless otherwise noted $V_{in} = 5.00$ Volts dc and $T_a = 25^{\circ}\text{C}$.

Characteristic	Symbol	Min	Typ	Max	Units
Input Voltage	V_{in}	+4.50	+5.00	+5.25	Vdc
Component Surface Temperature (Note 1)	T_s	-20	-	+80	°C
Input Current (Note 2)	I_{in}	-	0.64	0.73	Adc
Input Ripple Current	I_{rip}	-	20	-	mA _{pk-pk}
Operating Frequency	F_o	36	41	46	kHz
Minimum Output Voltage (Note 3)	$V_{out} \text{ (min)}$	1300	-	-	Vrms
Efficiency	η	-	74	-	%
Output Current (per lamp)	I_{out}	-	6.1	-	mArms
Output Voltage	V_{out}	-	390	-	Vrms
Enable Pin (Note 4)					
Turn-off Threshold	V_{thoff}	GND	-	1.0	Vdc
Turn-on Threshold	V_{thon}	2.5	-	V_{in}	Vdc
Impedance to V_{in}	R_{Enable}	19	20	21	kOhms

Specifications subject to change without notice.

(Note 1) Surface temperature must not exceed 80 degrees C; thermal management actions may be required.

(Note 2) Input current in excess of maximum may indicate a load/inverter mismatch condition, which can result in reduced reliability. Please contact ERG technical support.

(Note 3) Provided data is not tested but guaranteed by design.

(Note 4) The inverter is always enabled with an internal pullup resistor tied to the enable pin. A ground on the enable input will turn the inverter off.

Application Notes:

- 1) The minimum distance from high voltage areas of the inverter to any conductive material should be .12 inches per kilovolt of starting voltage.
- 2) Mounting hardware to be non-conductive.
- 3) Open framed inverters should not be used in applications at altitudes over 10,000 feet.
- 4) ACreturn should be left floating, not grounded.
- 5) Contact ERG for possible exceptions.



Onboard PWM

Unless otherwise noted $V_{in} = 5.00$ Volts DC, $T_a = 25$ °C and unit has been running for 5 minutes.

Characteristic	Symbol	Min	Typ	Max	Units
Frequency	f_{pwm}	-	160	-	Hz
Control Input Bias Current	I_{cbias}	-	-	10	μA

Pin Descriptions

+Vin Input voltage to the inverter.

GND Inverter ground.

Control Analog voltage input to the onboard pulse width modulator. Increasing this voltage increases the off time of the onboard PWM resulting in decreased brightness. The inverter is full on when this voltage is near inverter ground.

Enable Inverter Enable. The inverter is always enabled with an internal pullup resistor tied to the enable pin. Pull this pin low to disable inverter operation. The onboard PWM is always utilized.

Application information

The 8mD series of inverters is designed to power one cold cathode fluorescent lamp with up to four watts. An external analog control interfaces with an onboard pulse width modulator to provide dimming control. The 8mD inverter can reliably dim to less than 5% duty cycle.

External shutdown of the inverter is accomplished using the Enable pin. Pulling this pin low (below V_{thoff}) disables the inverter.

If analog voltage dimming is required, the analog voltage is applied to the Control pin. Figure 1 shows how to connect the inverter for onboard PWM operation. Graph 1 shows the relationship of PWM duty cycle to input control voltage.

If an external PWM is used, simply connect the Enable pin to the PWM source and connect the Control pin to inverter ground. If the onboard PWM is used, connect the analog voltage to the Control pin.

Coating All surfaces, except connectors, are conformally coated with an Acrylic Resin (AR) coating.

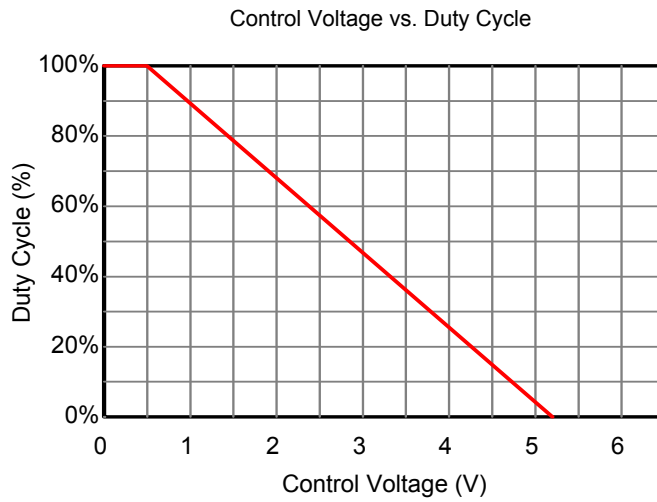

Graph 1

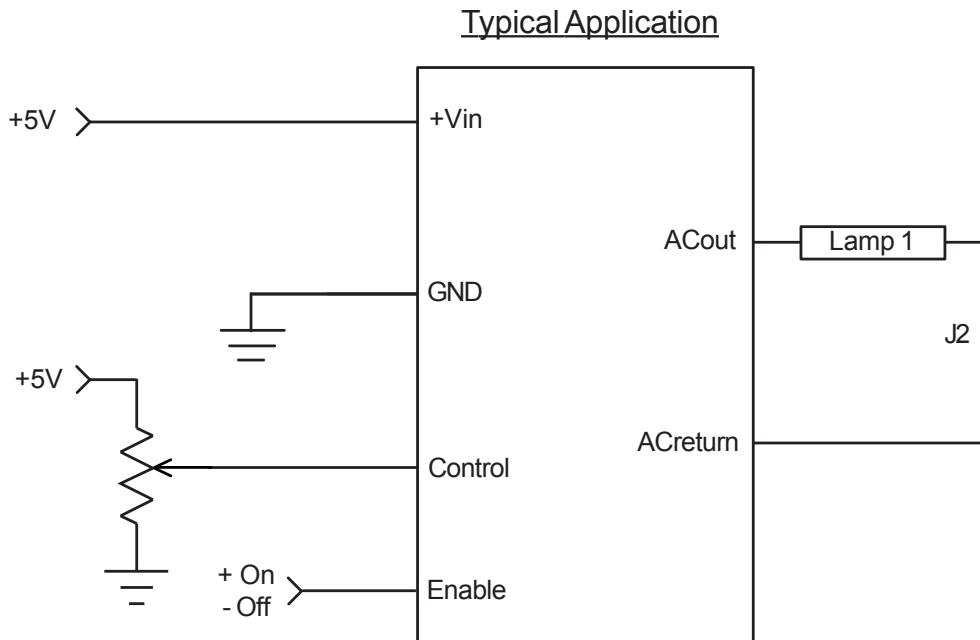

Figure 1



Endicott Research Group, Inc. (ERG) reserves the right to make changes in circuit design and/or specifications at any time without notice. Accordingly, the reader is cautioned to verify that data sheets are current before placing orders. Information furnished by ERG is believed to be accurate and reliable. However, no responsibility is assumed by ERG for its use.