



Endicott Research Group, Inc.

2601 Wayne St., Endicott, NY 13760
 607-754-9187 Fax 607-754-9255
<http://www.ergpower.com>

Specifications and Applications Information

05/10/04

Preliminary

The ERG 8mAD3083 (8m Series) DC to AC inverter features onboard connectors and can be easily dimmed using an external analog control signal or external PWM generator.

Powered by a regulated +5 Volt DC source, the 8mAD3083 is designed to power the NEC NL8060BC31-27 display backlight.

Product Features

- ✓ Small Package Size, less than 9mm in height.
- ✓ High Dimming Ratio
- ✓ High Efficiency
- ✓ Made in U.S.A.

This unit complements our 8m Series of DC to AC Inverters

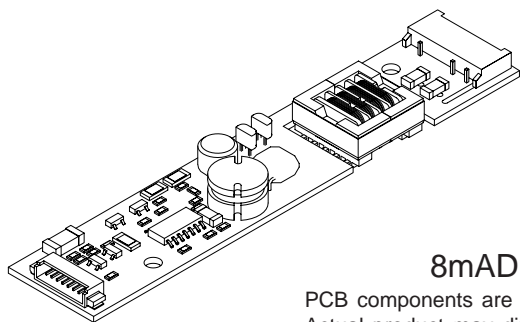

8mAD Package

PCB components are shown for reference only.
 Actual product may differ from that shown.

Connectors

Input J1
 Molex 532-61-0890

Output J2
 JST SM04(4.0)B-BHS-1-TB

8mAD3083

Two Tube
 DC to AC Inverter

Package Configuration

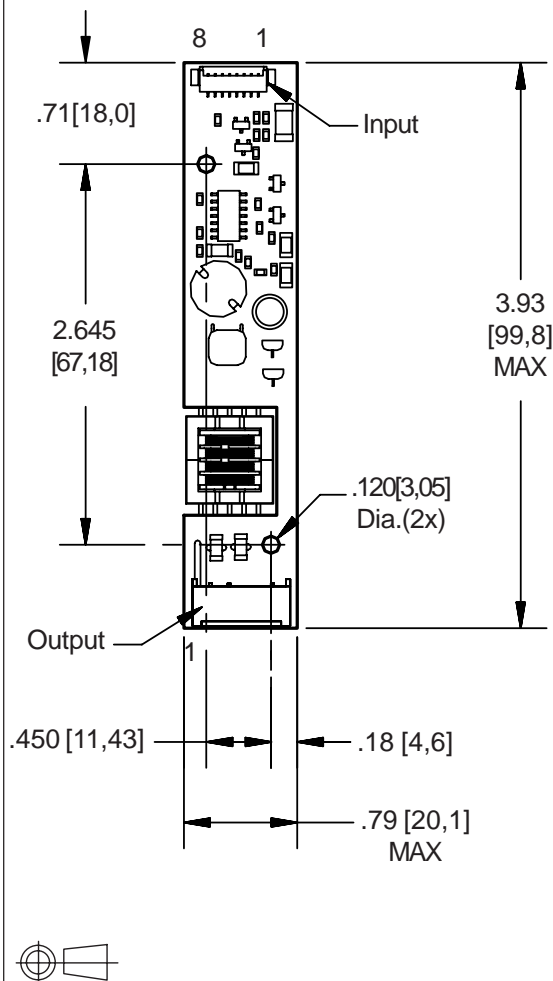

Pin Descriptions

J1-1 Vin	J2-1 ACout
J1-2 Vin	J2-2 ACout
J1-3 GND	J2-3 N/C
J1-4 GND	J2-4 ACcommon
J1-5 Enable	
J1-6 Control	
J1-7 N/C	
J1-8 GND	



Absolute Maximum Ratings (Note 1)

Rating	Symbol	Value	Units
Input Voltage	V_{in}	-0.3 to +5.5	Vdc
Disable	V_{Enable}	-0.3 to +0.3	Vdc
Operating Temperature	T_a	-0 to +70	°C
Storage Temperature	T_s	-40 to +80	°C

Recommended Operating Conditions

Rating	Symbol	Value	Units
Input Voltage	V_{in}	+4.50 to 5.25	Vdc
Operating Temperature <small>(Note 2)</small>	T_a	0 to +50	°C

Electrical Characteristics

Unless otherwise noted $V_{in} = 5.00$ Volts dc and $T_a = 25^\circ\text{C}$

Characteristic	Symbol	Min	Typ	Max	Units
Input Current	I_{in}	-	1.52	1.74	A_{DC}
Input Ripple Current	I_{rip}	-	20	-	mA_{pk-pk}
Operating Frequency	F_o	39	44	49	KHz
Efficiency	η	-	80	-	%
Output Voltage	V_{start}	1250	-	-	V
Output Voltage <small>(Note 3)</small>	V_{out}	-	600	-	V
Output Current per output	I_{out}	-	5.0	-	mA_{rms}
Enable (pin J1-5) <small>(Note 4)</small>					
Turn-off Threshold	V_{thoff}	0	-	1	V
Turn-On Threshold	V_{thon}	2.5	-	V_{in}	V
Impedance to V_{in}	$R_{Disable}$	44.6	47	49.4	kOhms

(Note 1) Reliable and predictable operation of the device is not guaranteed with applied stresses at or beyond those listed in "Absolute Maximum Ratings". Operation at these limits may reduce device reliability and is therefore not recommended. Please refer to "Recommended Operating Conditions" for reliable operation of the device.

(Note 2) Reliable operation above 50°C is possible if airflow is provided.

(Note 3) When powering a load simulating the referenced display

(Note 4) The inverter is always enabled with an internal pullup resistor tied to the enable pin. A ground on the enable input will turn the inverter off.

Application Notes:

- 1) The minimum distance from high voltage areas of the inverter to any conductive material should be .12 inches per kilovolt of starting voltage.
- 2) Mounting hardware should be non-conductive.
- 3) Open framed inverters should not be used in applications at altitudes over 10,000 feet.
- 4) Contact ERG for possible exceptions.



Onboard PWM

Unless otherwise noted $V_{in} = 5.00$ Volts DC , $T_a = 25$ °C and unit has been running for 5 minutes.

Characteristic	Symbol	Min	Typ	Max	Units
Frequency	f_{pwm}	-	160	-	Hz
Control Input Bias Current	I_{cbias}	-	-	10	μA

Pin Descriptions

Vin Input voltage to the inverter.

GND Inverter ground.

Control Analog voltage input to the onboard pulse width modulator. Increasing this voltage increases the off time of the onboard PWM resulting in decreased brightness. The inverter is full on when this voltage is near inverter ground.

Enable Inverter Enable. The inverter is always enabled with an internal pullup resistor tied to the enable pin. Pull this pin low to disable inverter operation. The onboard PWM is always utilized.

Application information

The 8mAD series of inverters is designed to power two cold cathode fluorescent tubes each with four watts. An external analog control interfaces with an onboard pulse width modulator to provide dimming control. The 8mAD inverter can reliably dim to less than 5% duty cycle.

External shutdown of the inverter is accomplished using the Enable pin. Pulling this pin low (below V_{thoff}) disables the inverter.

If analog voltage dimming is required, the analog voltage is applied to the Control pin. Figure 1 shows how to connect the inverter for onboard PWM operation. Graph 1 shows the relationship of PWM duty cycle to input control voltage.

If an external PWM is used, simply connect the Enable pin to the PWM source and connect the Control pin to inverter ground. If the onboard PWM is used, connect the analog voltage to the Control pin.



Control Voltage vs. Duty Cycle

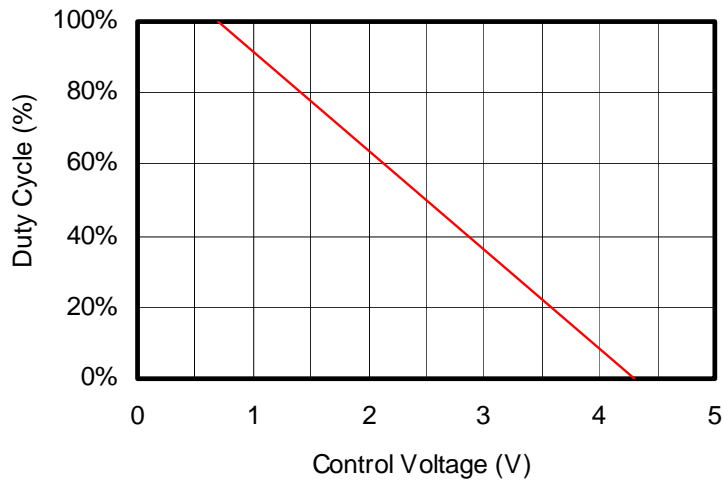

Graph 1

Typical Application

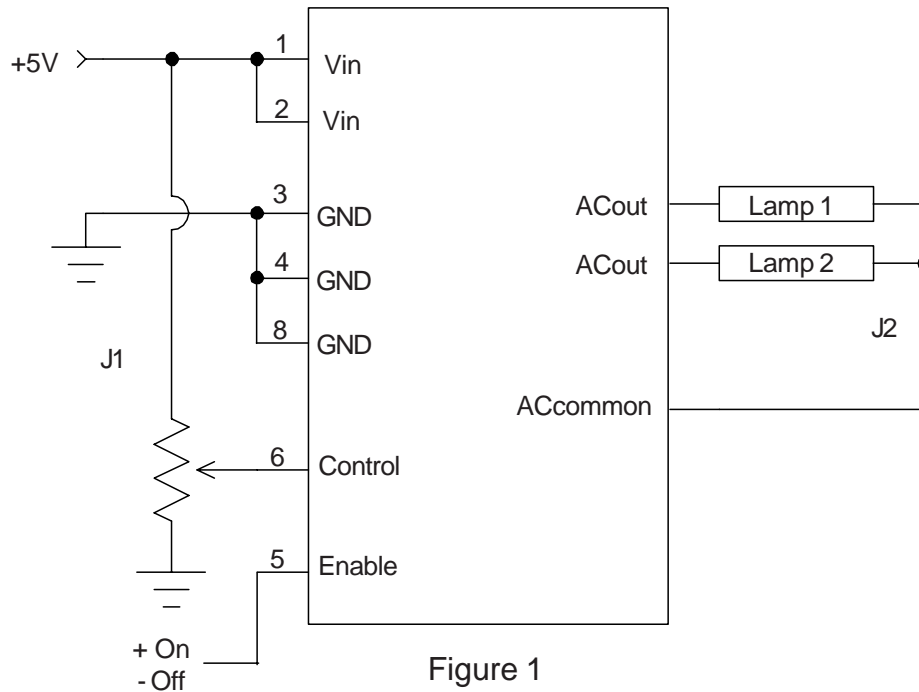

Figure 1



Endicott Research Group, Inc. (ERG) reserves the right to make changes in circuit design and/or specifications at any time without notice. Accordingly, the reader is cautioned to verify that data sheets are current before placing orders. Information furnished by ERG is believed to be accurate and reliable. However, no responsibility is assumed by ERG for its use.