



# Endicott Research Group, Inc.

2601 Wayne St., Endicott, NY 13760  
 607-754-9187 Fax 607-754-9255  
<http://www.ergpower.com>

## Specifications and Applications Information

04/22/04

Preliminary

The ERG 8mAD2791 (8m Series) DC to AC inverter features onboard connectors and can be easily dimmed using an external analog control signal or external PWM generator.

Powered by a regulated +12 Volt DC source, the 8mAD2791 is designed to power the Optrex T-51410D104J-FW-P-AE display backlight.

### Product Features

- ✓ Small Package Size, less than 9mm in height.
- ✓ High Dimming Ratio
- ✓ High Efficiency
- ✓ Made in U.S.A.

This unit complements our 8m Series of DC to AC Inverters

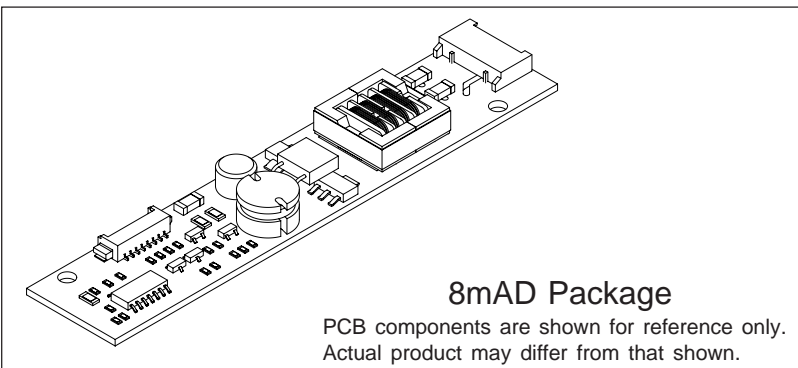

### Connectors

Input J1 Molex 532-61-0890	Output J2 JST SM03(4.0)B-BHS-1-TB
-------------------------------	--------------------------------------

# 8mAD2791

## Two Tube DC to AC Inverter

### Package Configuration

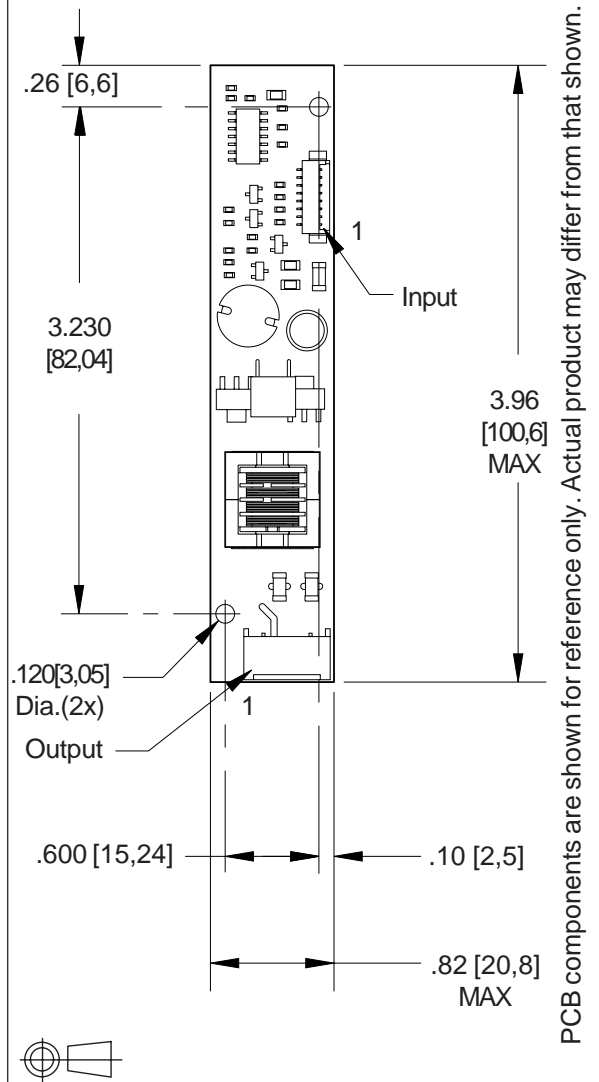

### Pin Descriptions

J1-1 Vin	J2-1 ACcommon
J1-2 Vin	J2-2 ACout
J1-3 GND	J2-3 ACout
J1-4 GND	
J1-5 Enable	
J1-6 Control	
J1-7 N/C	
J1-8 GND	



## Absolute Maximum Ratings (Note 1)

Rating	Symbol	Value	Units
Input Voltage	$V_{in}$	-0.3 to +13.2	Vdc
Disable	$V_{Enable}$	-0.3 to +0.3	Vdc
Operating Temperature	$T_a$	-0 to +85	°C
Storage Temperature	$T_s$	-40 to +85	°C

## Recommended Operating Conditions

Rating	Symbol	Value	Units
Input Voltage	$V_{in}$	+10.8 to 12.6	Vdc
Operating Temperature <small>(Note 2)</small>	$T_a$	0 to +50	°C

## Electrical Characteristics

Unless otherwise noted  $V_{in} = 12.00$  Volts dc and  $T_a = 25^\circ\text{C}$

Characteristic	Symbol	Min	Typ	Max	Units
Input Current	$I_{in}$	-	.71	.82	$A_{DC}$
Input Ripple Current	$I_{rip}$	-	20	-	$mA_{pk-pk}$
Operating Frequency	$F_o$	37	42	47	KHz
Efficiency	$\eta$	-	86	-	%
Output Voltage	$V_{start}$	1500	-	-	V
Output Voltage <small>(Note 3)</small>	$V_{out}$	-	600	-	V
Output Current	$I_{out}$	-	6.1	-	mArms
<b>Enable</b> (pin J1-5) <small>(Note 4)</small>					
Turn-off Threshold	$V_{thoff}$	0	-	1	V
Turn-On Threshold	$V_{thon}$	2.5	-	$V_{in}$	V
Impedance to $V_{in}$	$R_{Disable}$	44.6	47	49.4	kOhms

**(Note 1)** Reliable and predictable operation of the device is not guaranteed with applied stresses at or beyond those listed in "Absolute Maximum Ratings". Operation at these limits may reduce device reliability and is therefore not recommended. Please refer to "Recommended Operating Conditions" for reliable operation of the device.

**(Note 2)** Reliable operation above 50°C is possible if airflow is provided.

**(Note 3)** When powering a load simulating the referenced display

**(Note 4)** The inverter is always enabled with an internal pullup resistor tied to the enable pin. A ground on the enable input will turn the inverter off.

Input voltage specification modified for clarity 4/2004



## Onboard PWM

Unless otherwise noted  $V_{in} = 12.00$  Volts DC ,  $T_a = 25$  °C and unit has been running for 5 minutes.

Characteristic	Symbol	Min	Typ	Max	Units
Frequency	$f_{pwm}$	-	160	-	Hz
Control Input Bias Current	$I_{cbias}$	-	-	10	$\mu A$

## Pin Descriptions

**Vin** Input voltage to the inverter.

**GND** Inverter ground.

**Control** Analog voltage input to the onboard pulse width modulator. Increasing this voltage increases the off time of the onboard PWM resulting in decreased brightness. The inverter is full on when this voltage is near inverter ground.

**Enable** Inverter Enable. The inverter is always enabled with an internal pullup resistor tied to the enable pin. Pull this pin low to disable inverter operation. The onboard PWM is always utilized.

## Application information

The 8mAD series of inverters is designed to power two cold cathode fluorescent tubes each with four watts. An external analog control interfaces with an onboard pulse width modulator to provide dimming control. The 8mAD inverter can reliably dim to less than 5% duty cycle.

External shutdown of the inverter is accomplished using the Enable pin. Pulling this pin low (below  $V_{thoff}$ ) disables the inverter.

If analog voltage dimming is required, the analog voltage is applied to the Control pin. Figure 1 shows how to connect the inverter for onboard PWM operation. Graph 1 shows the relationship of PWM duty cycle to input control voltage.

If an external PWM is used, simply connect the Enable pin to the PWM source and connect the Control pin to inverter ground. If the onboard PWM is used, connect the analog voltage to the Control pin.

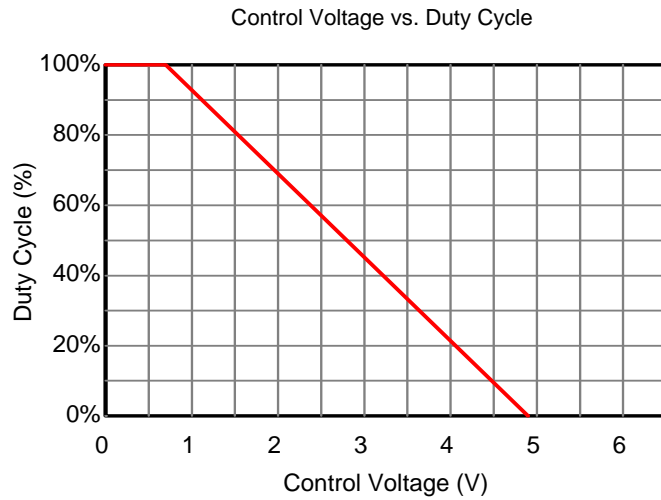

Graph 1

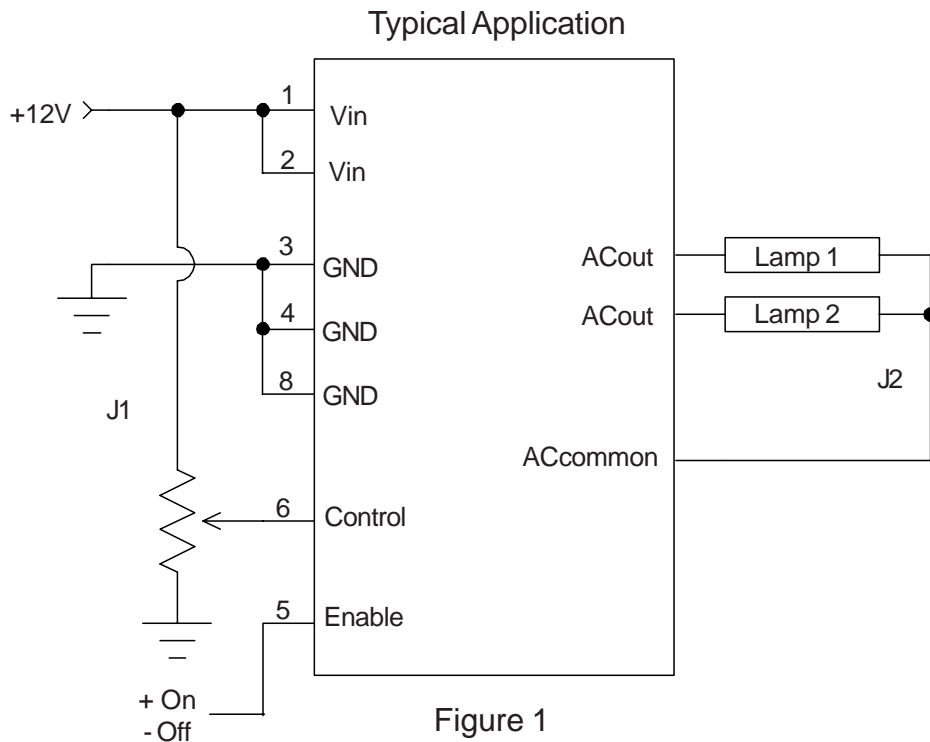

Endicott Research Group, Inc. (ERG) reserves the right to make changes in circuit design and/or specifications at any time without notice. Accordingly, the reader is cautioned to verify that data sheets are current before placing orders. Information furnished by ERG is believed to be accurate and reliable. However, no responsibility is assumed by ERG for its use.