



Endicott Research Group, Inc.

2601 Wayne St., Endicott, NY 13760
607-754-9187 Fax 607-754-9255
http://www.ergpower.com

Specifications and Applications Information

02/25/11

The ERG 8mA23483 (*8m Class*) low profile dc to ac inverter is specifically designed to power the NEC NL6448BC33-18, NL6448BC33-54, and NL6448BC33-63D LCD display backlights to a moderate brightness level from a +12 Volt dc source.

This low profile inverter features:

- ✓ Less Than 8 mm in Height
- ✓ LCD Module Specific
- ✓ Display Compatible Output Connector
- ✓ Firm Specifications
- ✓ Application Information
- ✓ Designed, Manufactured and Supported in the USA
- ✓ Custom Input and Output Voltages
- ✓ Flexible System Interface
- ✓ Notebook Display Head Compatible

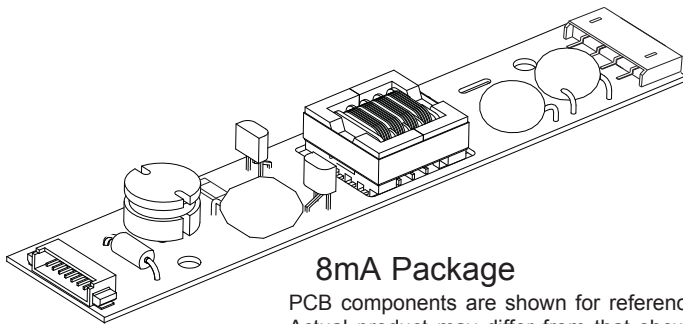

8mA Package

PCB components are shown for reference only.
Actual product may differ from that shown.

Connectors

Input J1
Molex
53261-0871

Output J2
JST
SM04(4.0)B-BHS-1-TB

8mA23483

Two Lamp
DC to AC Inverter

Package Configuration

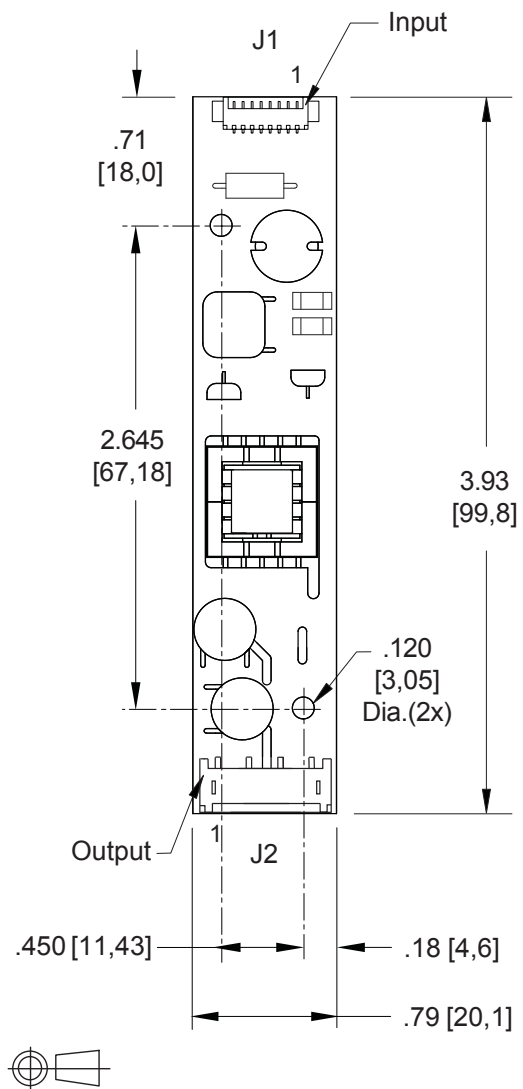

Pin Descriptions

J1-1 +Vin	J2-1 ACout
J1-2 +Vin	J2-2 ACout
J1-3 GND	J2-3 ACreturn
J1-4 GND	J2-4 ACreturn
J1-5 Enable	
J1-6 N/C	
J1-7 N/C	
J1-8 GND	

Absolute Maximum Ratings

Rating	Symbol	Value	Units
Input Voltage Range	V_{in}	-0.3 to +13.2	Vdc
Storage Temperature	T_{stg}	-40 to +85	°C

Operating Characteristics

With the referenced display and lamp warm-up of 5 minutes.
Unless otherwise noted $V_{in} = 12.00$ Volts dc and $T_a = 25^{\circ}\text{C}$.

Characteristic	Symbol	Min	Typ	Max	Units
Input Voltage	V_{in}	+10.8	+12.0	+12.6	Vdc
Component Surface Temperature ^(note 1)	T_s	-20	-	+80	°C
Input Current ^(note 2)	I_{in}	-	0.47	0.52	Adc
Operating Frequency	F_o	41	46	51	kHz
Minimum Output Voltage ^(note 3)	V_{out} (min)	1250	-	-	Vrms
Efficiency	η	-	90	-	%
Output Current (per lamp)	I_{out}	-	5.0	-	mArms
Output Voltage	V_{out}	-	510	-	Vrms
Enable Pin Input Current Requirement ^(note 4)	I_{enable}	-	7	-	mAdc

Specifications subject to change without notice.

(Note 1) Surface temperature must not exceed 80 degrees C; thermal management actions may be required.

(Note 2) Input current in excess of maximum may indicate a load/inverter mismatch condition, which can result in reduced reliability. Please contact ERG technical support.

(Note 3) Provided data is not tested but guaranteed by design.

(Note 4) Required User Enable/Disable Interface Circuit is shown on page 3.

Application Notes:

- 1) The minimum distance from high voltage areas of the inverter to any conductive material should be .12 inches per kilovolt of starting voltage.
- 2) Mounting hardware to be non-conductive.
- 3) Open framed inverters should not be used in applications at altitudes over 10,000 feet.
- 4) ACreturn should be left floating, not grounded.
- 5) Contact ERG for possible exceptions.



Endicott Research Group, Inc.

2601 Wayne St., Endicott, NY 13760
607-754-9187 Fax 607-754-9255
<http://www.ergpower.com>

PWM Dimming

Required User Enable/Disable Interface Circuit

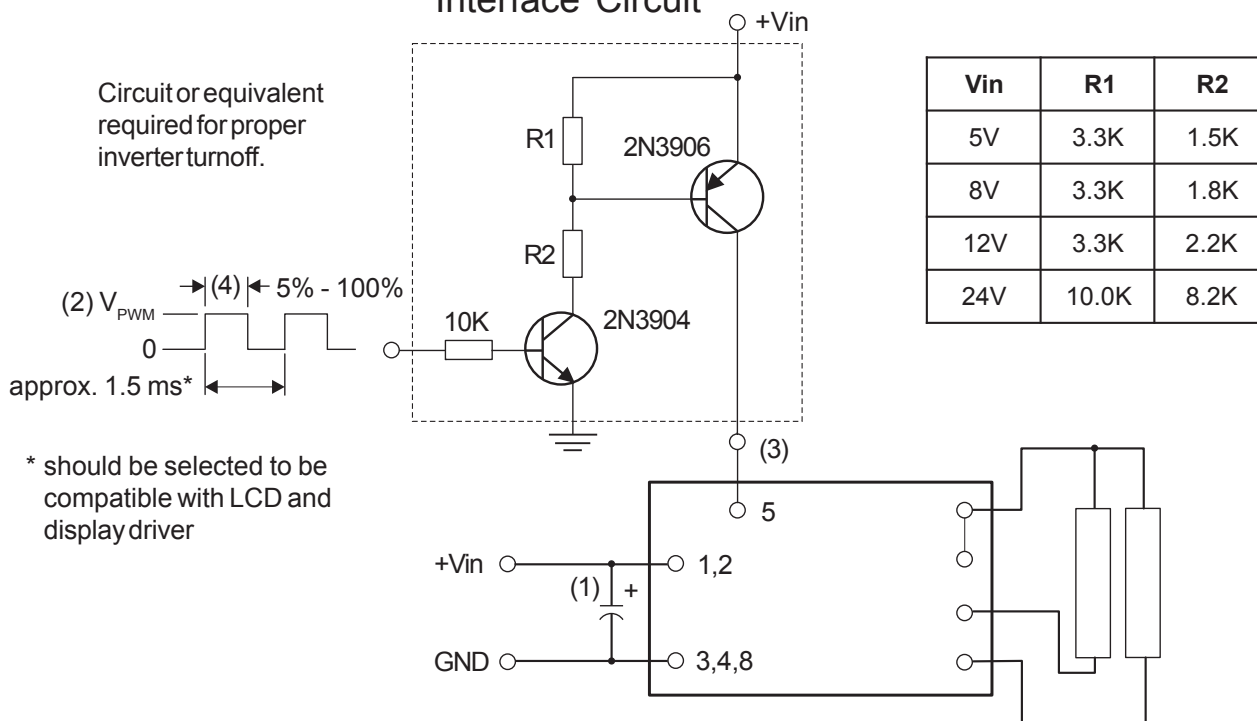

- (1) Low ESR type input by-pass capacitor (22 μ F - 100 μ F) may be required to reduce reflected ripple.
- (2) $V_{P_{PWM}}$ from 2.4V to less than or equal to $+V_{in}$.
- (3) Full brightness without PWM control requires that pin 5 be tied to $+V_{in}$. Pin 5 must be at 0V to turn off.
- (4) Duty Cycle 5% - 100%.



Endicott Research Group, Inc. (ERG) reserves the right to make changes in circuit design and/or specifications at any time without notice. Accordingly, the reader is cautioned to verify that data sheets are current before placing orders. Information furnished by ERG is believed to be accurate and reliable. However, no responsibility is assumed by ERG for its use.