



Endicott Research Group, Inc.

2601 Wayne St., Endicott, NY 13760
 607-754-9187 Fax 607-754-9255
<http://www.ergpower.com>

Specifications and Applications Information

11/11/05

Preliminary

The ERG 8m122723 (**8m Class**) low profile dc to ac inverter is specifically designed to power the Hitachi SX14Q001-ZZA LCD display module to a moderate brightness level from a +12 volt dc source.

This low profile inverter features:

- ✓ Less Than 8 mm in Height
- ✓ LCD Module Specific
- ✓ Display Compatible Output Connector
- ✓ Firm Specifications
- ✓ Application Information
- ✓ Designed, Manufactured and Supported in the USA
- ✓ Custom Input and Output Voltages
- ✓ Flexible System Interface
- ✓ Notebook Display Head Compatible

8m122723

8m Class DC to AC Inverter

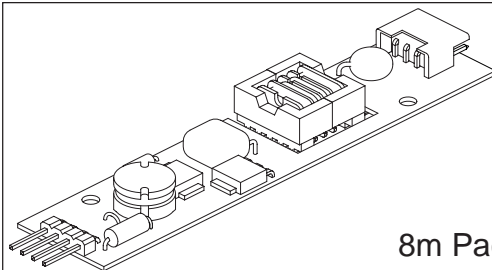

8m Package

PCB components are shown for reference only. Actual product may differ from that shown.

Package Configuration

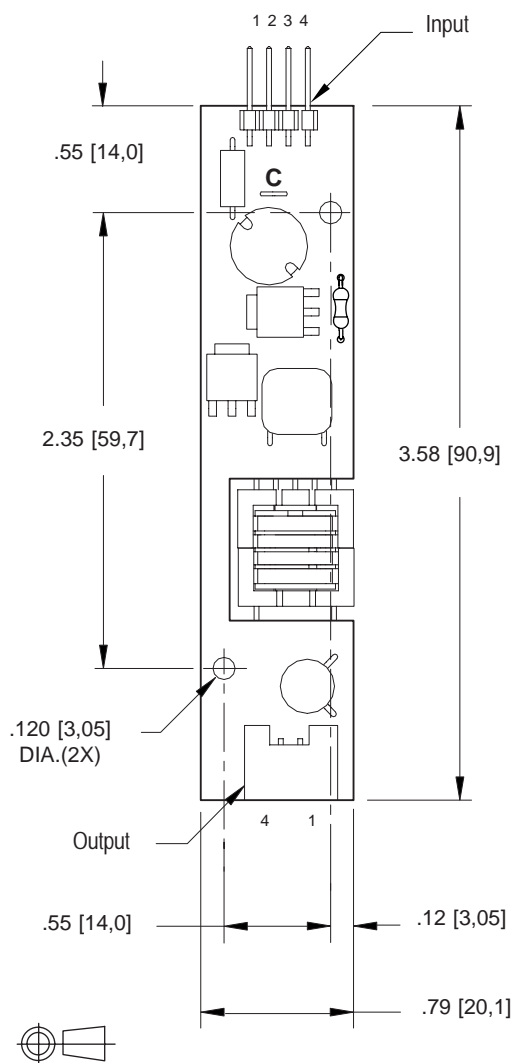

PCB components are shown for reference only. Actual product may differ from that shown.

Connectors

Input Connector	Output Connector
4 pins are 0.315" [8,00] Long, 0.025" [0,63] Square and are on 0.100" [2,54] Centers.	JAE IL-G-4P-S3L2-E
J1-1 Vin(+) J1-2 GND J1-3 Enable * J1-4 N/C	J2-1 ACout J2-2 N/C J2-3 N/C J2-4 ACout
* Valid when the "C" Jumper is removed	

Absolute Maximum Ratings

Rating	Symbol	Value	Units
Input Voltage Range	Vin	-0.3 to +13.2	Vdc
Operating Temperature	To	0 to +70	°C
Storage Temperature	Tstg	-40 to +85	°C

Recommended Operating Conditions

Rating	Symbol	Value	Units
Input Voltage	Vin	+10.8 to 12.6	Vdc

Electrical Characteristics

Unless otherwise noted Vin = 12.00 Volts dc and Ta = 25°C

Characteristic	Symbol	Min	Typ	Max	Units
Input Current ^(note 1)	Iin	-	.25	.29	Adc
Operating Frequency	Fo	36	41	46	KHz
Minimum Output Voltage	Vout (min)	1100	-	-	Vrms
Efficiency	h	-	76	-	%
Output Current (per lamp)	Iout	-	6	-	marms
Output Voltage (When powering a load simulating the referenced display)	Vout	-	381	-	Vrms
Pin3 Input Current Requirement	-	-	8	-	madc

After lamp has been allowed to warm-up for 5 minutes.
External Disable Circuit shown on page 3.

Specifications subject to change without notice.

11/11/05 - Corrected Typical Input Current, Efficiency and Pin3 Input Current Requirement values. Revised format.

(Note 1) Input current in excess of maximum may indicate a load/inverter mismatch condition, which can result in reduced reliability. Please contact ERG technical support.

Application Notes:

- 1) The minimum distance from high voltage areas of the inverter to any conductive material should be .12 inches per kilovolt of starting voltage.
- 2) Mounting hardware should be non-conductive.
- 3) Open framed inverters should not be used in applications at altitudes over 10,000 feet.
- 4) Contact ERG for possible exceptions.



Endicott Research Group, Inc.

2601 Wayne St., Endicott, NY 13760
607-754-9187 Fax 607-754-9255
<http://www.ergpower.com>

Made in USA



3 Dimming Options

(Valid with the "C" jumper removed)

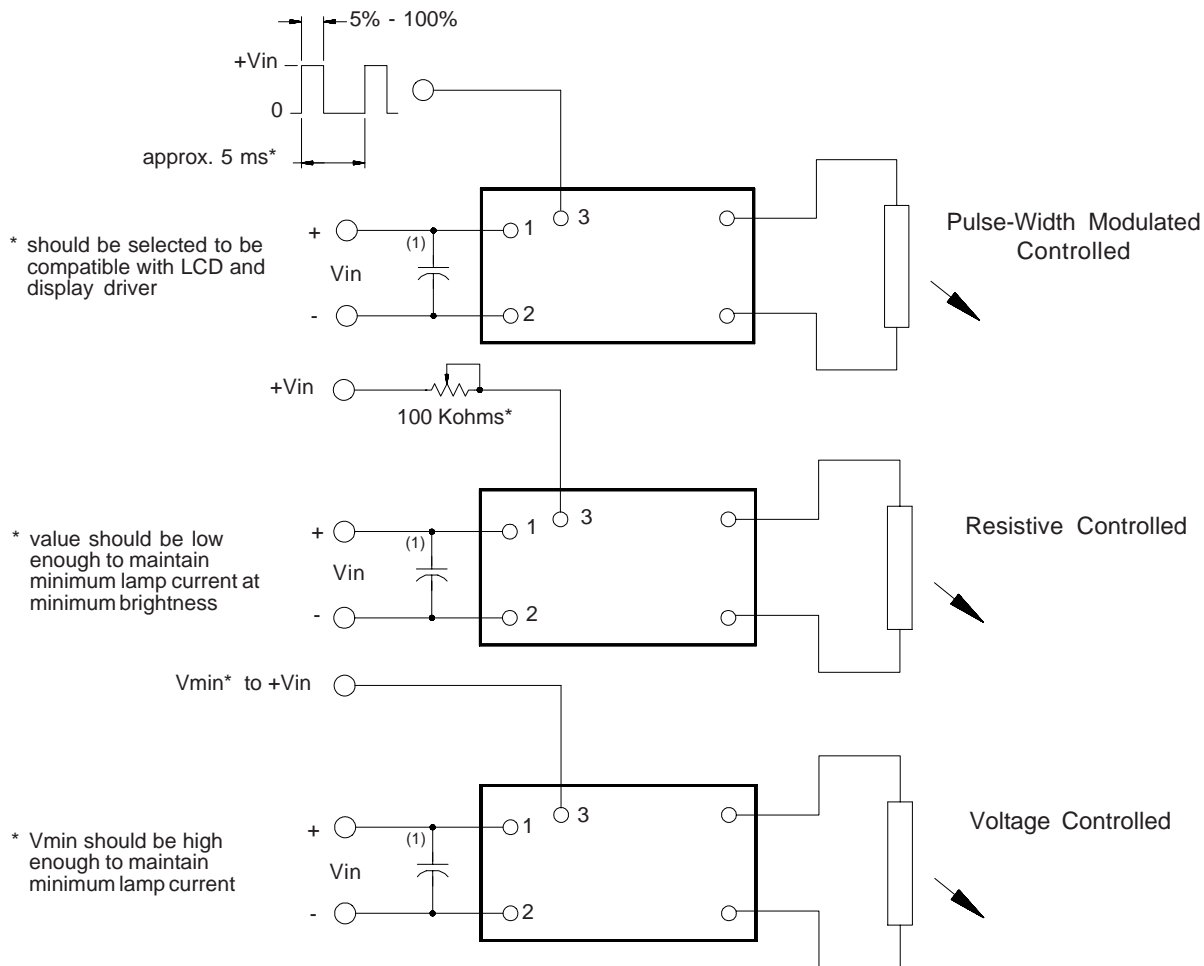

Note 1 - Low ESR type input by-pass capacitor (22 uf - 100 uf) may be required to reduce reflected ripple.

Disable Circuit

(Valid with the "C" jumper removed)

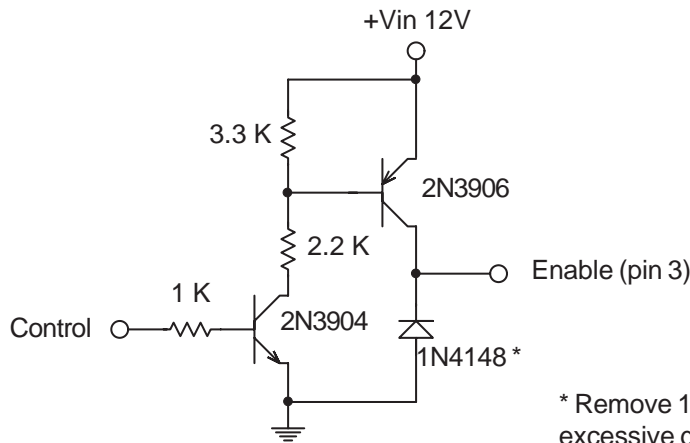

* Remove 1N4148 in applications where excessive ground bounce voltages exist.



Endicott Research Group, Inc. (ERG) reserves the right to make changes in circuit design and/or specifications at any time without notice. Accordingly, the reader is cautioned to verify that data sheets are current before placing orders. Information furnished by ERG is believed to be accurate and reliable. However, no responsibility is assumed by ERG for its use.