

8m122608

3 Dimming Options
(valid when the "C" jumper is removed)

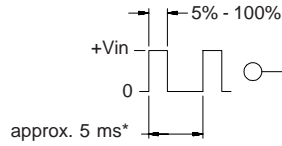

* should be selected to be compatible with LCD and display driver

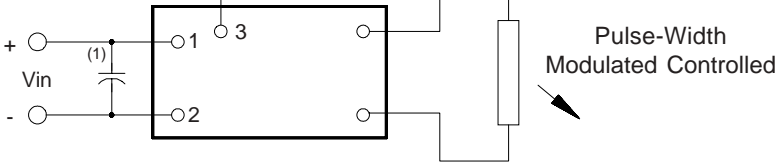

Pulse-Width Modulated Controlled

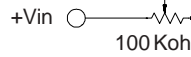

* value should be low enough to maintain minimum tube current at minimum brightness

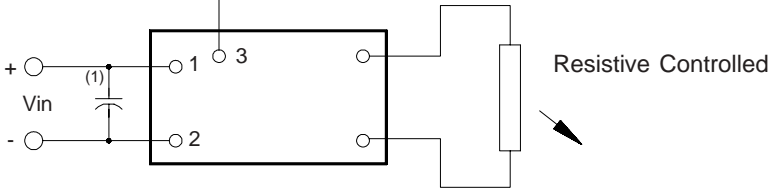

Resistive Controlled



* Vmin should be high enough to maintain minimum tube current

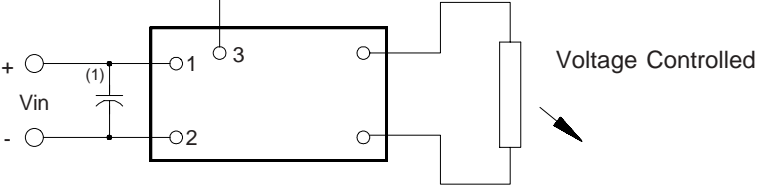

Voltage Controlled

Note 1 Input by-pass capacitor (25 uf - 100uf) may be required to reduce reflected ripple.



Endicott Research Group, Inc.

2601 Wayne St., Endicott NY 13760

607-754-9187



Endicott Research Group, Inc.

2601 Wayne St., Endicott NY 13760

607-754-9187 Fax 607-754-9255

<http://www.ergpower.com>

Specifications and Applications Information

06/17/02

Preliminary

The ERG 8m122608 (8m Class) low profile dc to ac inverter is specifically designed to power the Optrex T-51379L025J/L035J-FW-P-AA LCD display module to a moderate brightness level from a +12 volt dc source.

This low profile inverter features:

- ✓ Less Than 8 mm in Height
- ✓ LCD Module Specific
- ✓ Display Compatible Output Connector
- ✓ Firm Specifications
- ✓ Application Information
- ✓ Designed, Manufactured and Supported in the USA
- ✓ Custom Input and Output Voltages
- ✓ Flexible System Interface
- ✓ Notebook Display Head Compatible

Pin Descriptions

Input Connector	Output Connector
4 pins are 0.315" [8,00] Long, 0.025" [0,63] Square and are on 0.100" [2,54] Centers.	JST SM02(8.0)B-BHS-1-TB
Con1-1 Vin(+) Con1-2 GND Con1-3 Control* Con1-4 N/C	Con2-1 ACout Con2-2 N/C Con2-3 ACout
* Valid when "C" Jumper is removed	

8m122608

8m Class
DC to AC Inverter

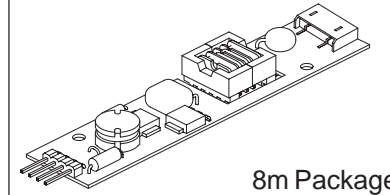

8m Package

Package Configuration

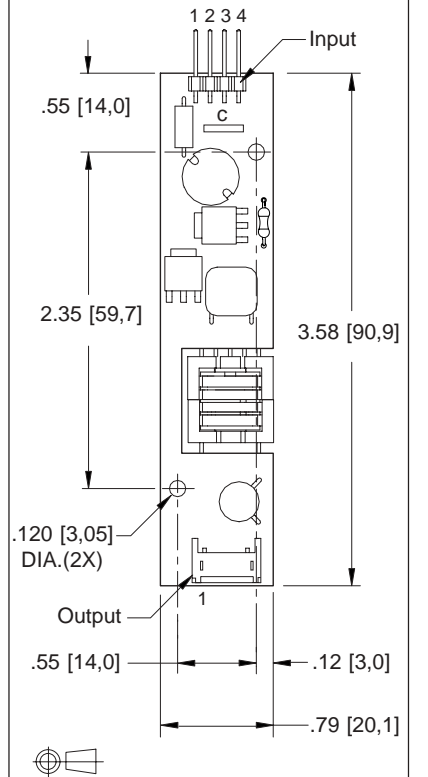

8m122608

Absolute Maximum Ratings

Rating	Symbol	Value	Units
Input Voltage Range	V _{in}	-0.3 to +13.2	Vdc
Operating Temperature	T _o	-0 to +70	°C
Storage Temperature	T _{stg}	-40 to +85	°C

Recommended Operating Conditions

Rating	Symbol	Value	Units
Input Voltage	V _{in}	+6 to 13.2	Vdc

Electrical Characteristics

Unless otherwise noted V_{in} = 12.00 Volts dc and T_a = 25 °C

Characteristic	Symbol	Min	Typ	Max	Units
Input Current	I _{in}	-	.08	.1	A _{dc}
Operating Frequency	F _o	26	31	36	KHz
Minimum Output Voltage	V _{out} (min)	1000	-	-	V _{rms}
Efficiency	η	-	70	-	%
Output Current	I _{out}	-	3	-	ma _{rms}
Output Voltage (When powering a Load simulating the referenced display.)	V _{out}	-	225	-	V _{rms}
Pin3 Input Current Requirement	-	-	3	-	ma _{dc}

After tube has been allowed to warm-up for 5 minutes
External Disable Circuit shown on page 3.

Specifications subject to change without notice.



Endicott Research Group, Inc.

Made in USA

Typical Performance Curves

8m122608

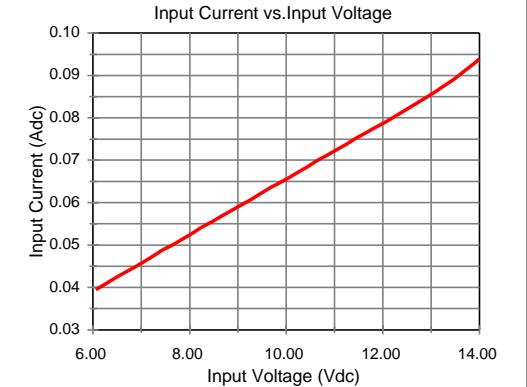
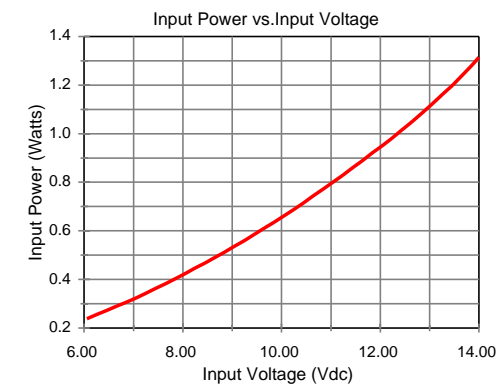
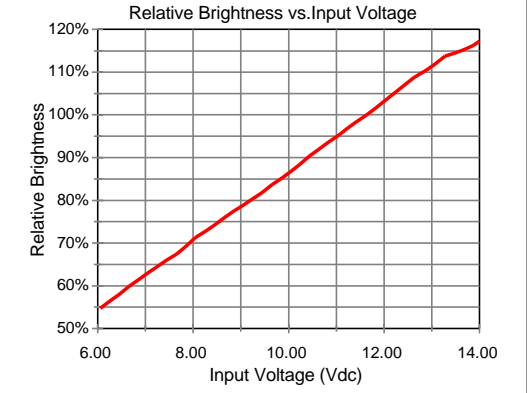
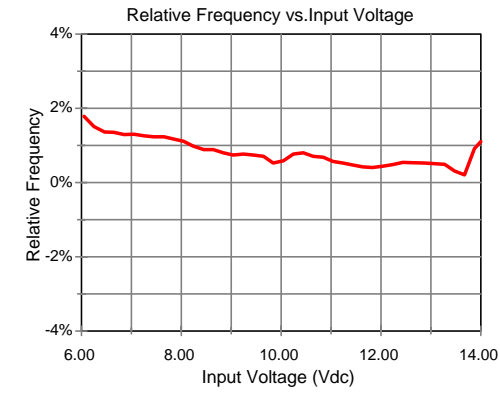

Disable Circuit

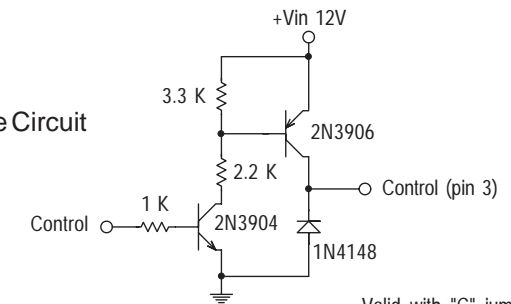

Valid with "C" jumper removed



Endicott Research Group, Inc.