



Endicott Research Group, Inc.

2601 Wayne St., Endicott, NY 13760  
 607-754-9187 Fax 607-754-9255  
<http://www.ergpower.com>

## Specifications and Applications Information

10/18/04

Preliminary

The ERG 8m122424 (**8m Class**) low profile DC to AC inverter is specifically designed to power the Hitachi LMG7525RPFF LCD display module to a moderate brightness level from a +12 volt dc source.

This low profile inverter features:

- ✓ Less Than 8 mm in Height
- ✓ LCD Module Specific
- ✓ Display Compatible Output Connector
- ✓ Firm Specifications
- ✓ Application Information
- ✓ Designed, Manufactured and Supported in the USA
- ✓ Custom Input and Output Voltages
- ✓ Flexible System Interface
- ✓ Notebook Display Head Compatible

# 8m122424

## 8m Class DC to AC Inverter

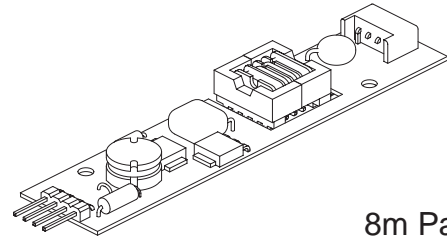

**8m Package**

PCB components are shown for reference only.  
 Actual product may differ from that shown.

### Package Configuration

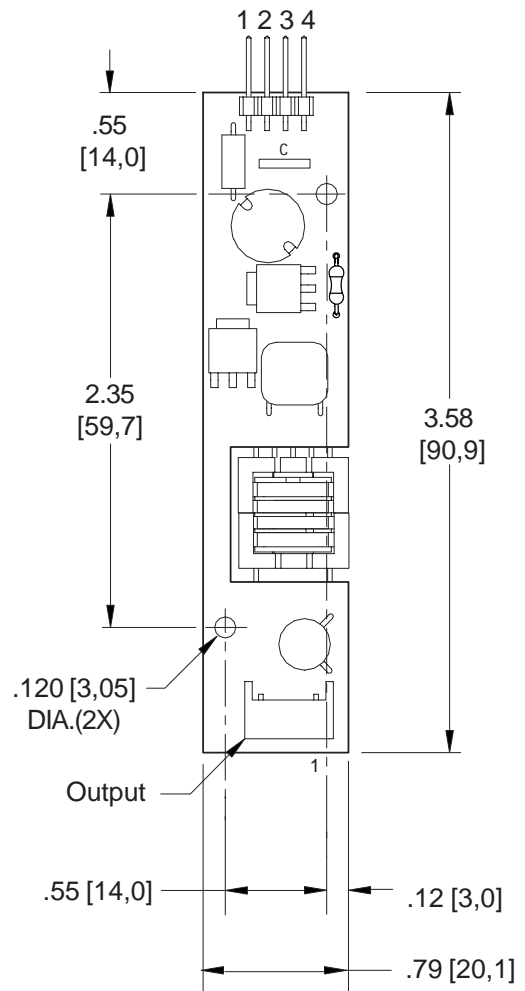

PCB components are shown for reference only. Actual product may differ from that shown.

### Connectors

Input Connector	Output Connector
4 pins are 0.315" [8,00] Long, 0.025" [0,63] Square and are on 0.100" [2,54] Centers.	Mitsumi M60-04-30-134P
J1-1 Vin(+) J1-2 Vin(-) J1-3 Control J1-4 N/C	J2-1 ACcommon J2-2 ACout

**Absolute Maximum Ratings**

Rating	Symbol	Value	Units
Input Voltage Range	Vin	-0.3 to +13.2	Vdc
Operating Temperature	To	-0 to +70	°C
Storage Temperature	Tstg	-40 to +85	°C

**Recommended Operating Conditions**

Rating	Symbol	Value	Units
Input Voltage	Vin	+10.8 to 12.6	Vdc

**Electrical Characteristics**

Unless otherwise noted Vin = 12.00 Volts dc and Ta = 25°C

Characteristic	Symbol	Min	Typ	Max	Units
Input Current <sup>(note 1)</sup>	Iin	-	.18	.21	Adc
Operating Frequency	Fo	30	35	40	KHz
Minimum Output Voltage	Vout (min)	1100	-	-	Vrms
Efficiency	-	-	74	-	%
Output Current (per lamp)	Iout	-	5.0	-	marms
Output Voltage (When powering a load simulating the referenced display)	Vout	-	310	-	Vrms

After lamp has been allowed to warm-up for 5 minutes  
External Disable Circuit shown on page 3.

Specifications subject to change without notice.

(Note 1) Input current in excess of maximum may indicate a load/inverter mismatch condition, which can result in reduced reliability. Please contact ERG technical support.

**Application Notes:**

- 1) The minimum distance from high voltage areas of the inverter to any conductive material should be .12 inches per kilovolt of starting voltage.
- 2) Mounting hardware should be non-conductive.
- 3) Open framed inverters should not be used in applications at altitudes over 10,000 feet.
- 4) Contact ERG for possible exceptions.



**Endicott Research Group, Inc.**

2601 Wayne St., Endicott, NY 13760  
607-754-9187 Fax 607-754-9255  
<http://www.ergpower.com>



Made in USA



### Dimming Option (Valid with "C" jumper removed)

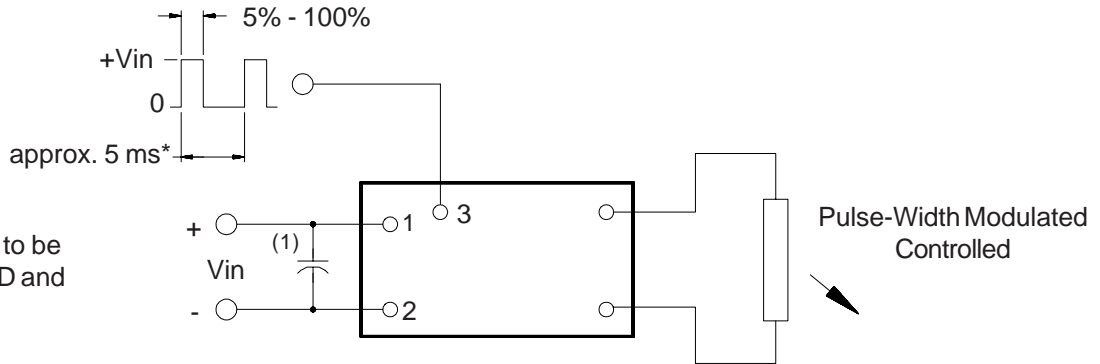

\* should be selected to be compatible with LCD and display driver

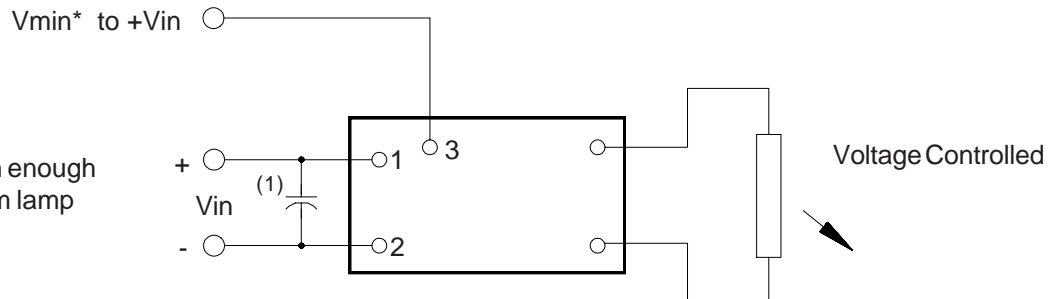

\* Vmin should be high enough to maintain minimum lamp current

Note 1 - Low ESR type input by-pass capacitor (22 uf - 100uf) may be required to reduce reflected ripple.

Endicott Research Group, Inc. (ERG) reserves the right to make changes in circuit design and/or specifications at any time without notice. Accordingly, the reader is cautioned to verify that data sheets are current before placing orders. Information furnished by ERG is believed to be accurate and reliable. However, no responsibility is assumed by ERG for its use.