

8m122325

3 Dimming Options

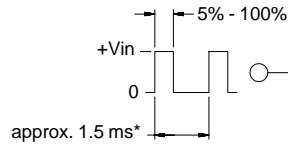

* should be selected to be compatible with LCD and display driver

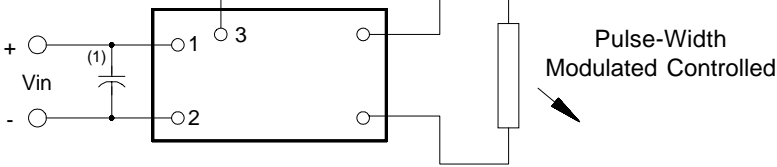

Pulse-Width Modulated Controlled

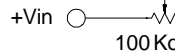

* value should be low enough to maintain minimum tube current at minimum brightness

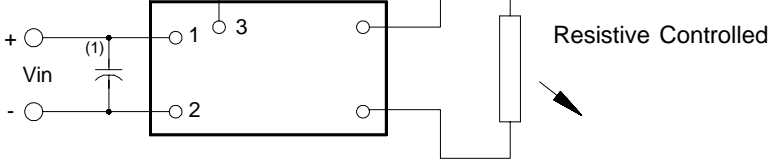

Resistive Controlled

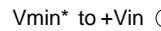

* Vmin should be high enough to maintain minimum tube current

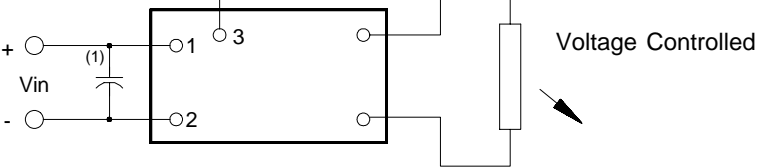

Voltage Controlled

Note 1 Input by-pass capacitor (25 uf - 100uf) may be required to reduce reflected ripple.



Endicott Research Group, Inc.

2601 Wayne St., Endicott NY 13760

607-754-9187



Endicott Research Group, Inc.

2601 Wayne St., Endicott NY 13760

607-754-9187 Fax 607-754-9255

<http://www.ergpower.com>

Specifications and Applications Information

3/17/00

Preliminary

The ERG 8m122325 (*8m Class*) low profile dc to ac inverter is specifically designed to power the AND08C343S LCD display module to a moderate brightness level from a +12 volt dc source.

This low profile inverter features:

- ✓ Less Than 8 mm in Height
- ✓ LCD Module Specific
- ✓ Display Compatible Output Connector
- ✓ Firm Specifications
- ✓ Application Information
- ✓ Designed, Manufactured and Supported in the USA
- ✓ Custom Input and Output Voltages
- ✓ Flexible System Interface
- ✓ Notebook Display Head Compatible

Pin Descriptions

Input Connector	Output Connector
4 pins are 0.315" [8,00] Long, 0.025" [0,63] Square and are on 0.100" [2,54] Centers.	JST SM02(8.0)B-BHS-1-TB
Con1-1 Vin(+) Con1-2 GND Con1-3 Control Con1-4 NC	Con2-1 ACout Con2-2 NC Con2-3 NC Con2-4 ACout

8m122325

8m Class
DC to AC Inverter

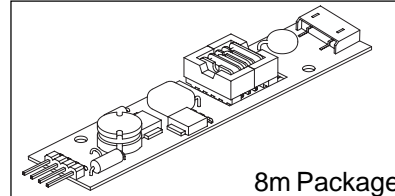

8m Package

Package Configuration

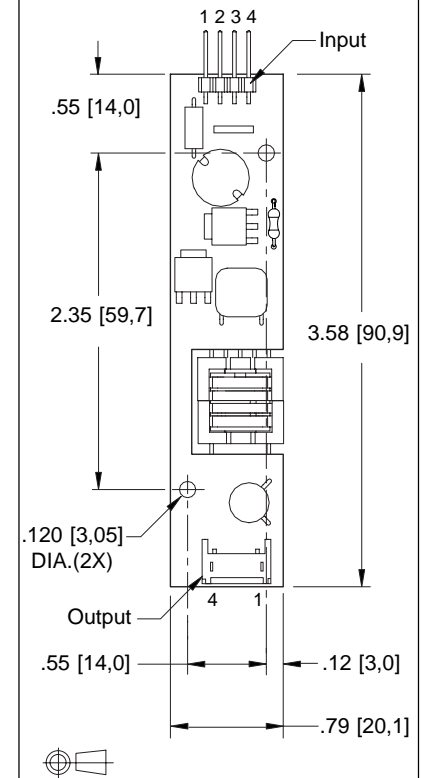

8m122325

Absolute Maximum Ratings

Rating	Symbol	Value	Units
Input Voltage Range	V_{in}	-0.3 to +13.2	Vdc
Operating Temperature	T_o	0 to +70	°C
Storage Temperature	T_{stg}	-40 to +85	°C

Recommended Operating Conditions

Rating	Symbol	Value	Units
Input Voltage	V_{in}	+6 to 13.2	Vdc

Electrical Characteristics

Unless otherwise noted $V_{in} = 12.00$ Volts dc and $T_a = 25$ °C

Characteristic	Symbol	Min	Typ	Max	Units
Input Current	I_{in}	-	.22	.25	A _{dc}
Operating Frequency	F_o	25	29	33	KHz
Minimum Output Voltage	$V_{out} (min)$	1400	-	-	V _{rms}
Efficiency	η	-	85	-	%
Output Current	I_{out}	-	5	-	mA _{rms}
Output Voltage (when Powering the AND08C343S display)	V_{out}	-	450	-	V _{rms}

After tube has been allowed to warm-up for 5 minutes
External Disable Circuit shown on page 3.

Specifications subject to change without notice.



Endicott Research Group, Inc.

Made in USA

Typical Performance Curves

8m122325

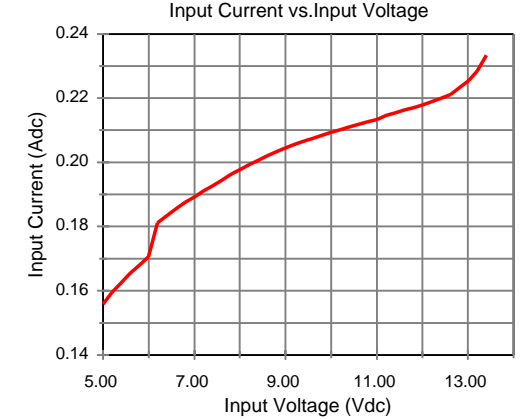
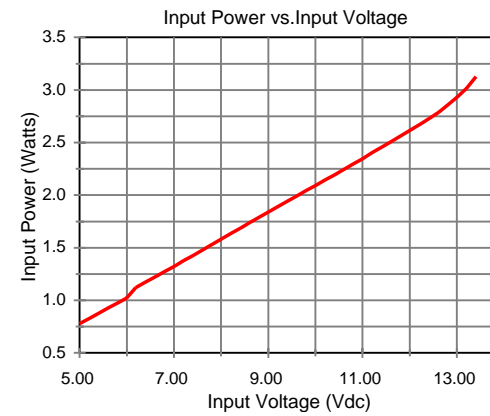
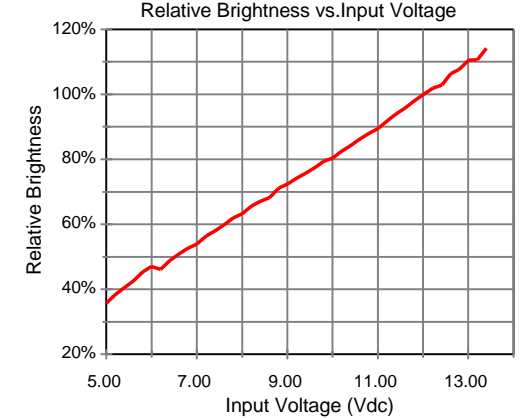
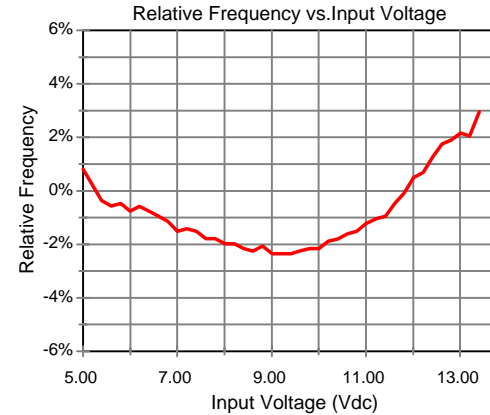

Disable Circuit

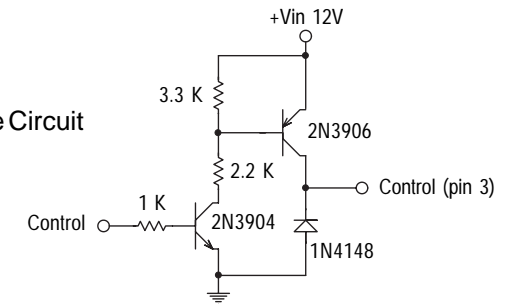

Endicott Research Group, Inc.