



Endicott Research Group, Inc.

2601 Wayne St., Endicott, NY 13760

607-754-9187 Fax 607-754-9255

http://www.ergpower.com

10mD3421

Specifications and Applications Information

03/08/11

10m Class
Single Lamp
DC to AC Inverter

The ERG 10mD3421 (10m Class) low profile dc to ac inverter is specifically designed to power the backlights of the following display(s) to a moderate brightness level from a +5 volt dc power supply.

- Kyocera TCG057QV1AD-G00
- Kyocera KCG057QV1DC-G50

This inverter can be dimmed using an external analog control voltage or an external PWM generator.

This low profile inverter features:

- ✓ Less Than 10 mm in Height
- ✓ LCD Module Specific
- ✓ Display Compatible Output Connector
- ✓ Firm Specifications
- ✓ High Dimming Ratio
- ✓ Application Information
- ✓ Designed, Manufactured and Supported in the USA
- ✓ Custom Input and Output Voltages
- ✓ Flexible System Interface

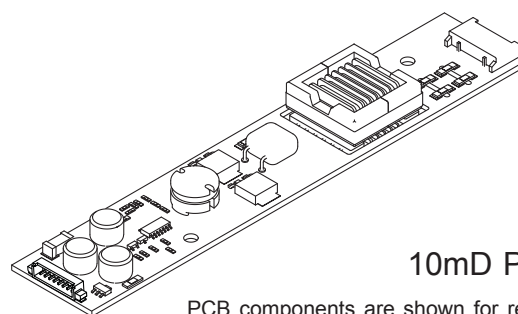

10mD Package

PCB components are shown for reference only. Actual product may differ from that shown.

Package Configuration

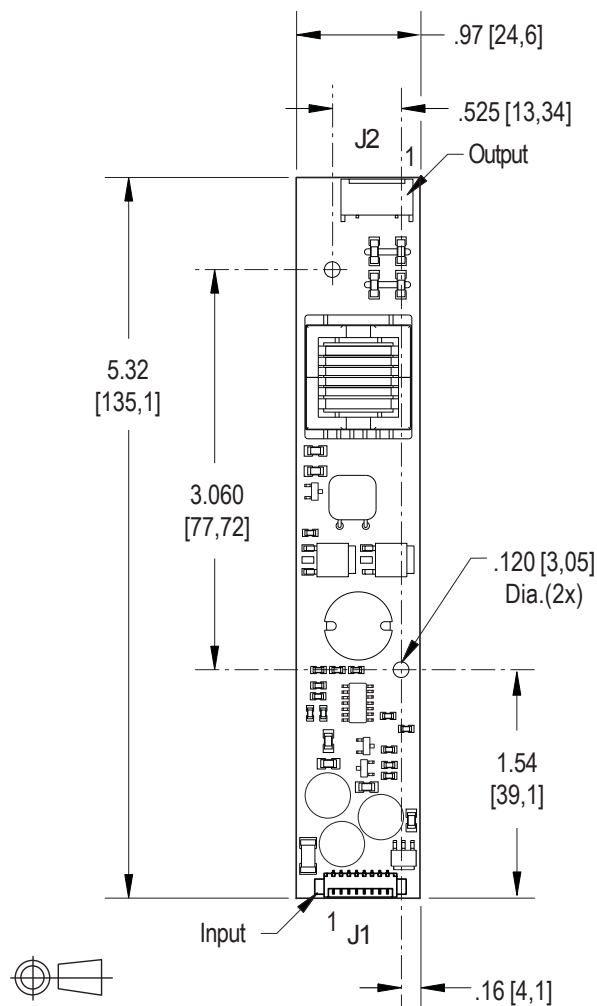

PCB components are shown for reference only. Actual product may differ from that shown.



Mass: 22 grams

Connectors

| Input Connector | Output Connector |
|---|-----------------------------|
| Molex 53261-0871 | JST SM02(8.0)B-BHS-1-TB |
| J1-1 +Vin J1-2 +Vin J1-3 GND J1-4 GND J1-5 Enable J1-6 Control J1-7 GND J1-8 GND | J2-1 ACout J2-2 ACreturn |

**Absolute Maximum Ratings**

| Rating | Symbol | Value | Units |
|---------------------|-----------|--------------|-------|
| Input Voltage Range | V_{in} | -0.3 to +5.5 | Vdc |
| Storage Temperature | T_{stg} | -40 to +85 | °C |

Operating Characteristics

With the referenced display and lamp warm-up of 5 minutes.
Unless otherwise noted $V_{in} = 5.00$ Volts dc and $T_a = 25^{\circ}\text{C}$

| Characteristic | Symbol | Min | Typ | Max | Units |
|--|-------------------------|-------|-------|----------|-------|
| Input Voltage | V_{in} | +4.50 | +5.00 | +5.25 | Vdc |
| Component Surface Temperature (note 1) | T_s | -20 | - | +80 | °C |
| Input Current (note 2) | I_{in} | - | 0.75 | 0.86 | Adc |
| Operating Frequency | F_o | 36 | 41 | 46 | kHz |
| Minimum Output Voltage (note 3) | $V_{out} \text{ (min)}$ | 2200 | - | - | Vrms |
| Efficiency | η | - | 77 | - | % |
| Output Current (per lamp) | I_{out} | - | 4.2 | - | mArms |
| Output Voltage | V_{out} | - | 685 | - | Vrms |
| Enable Pin (note 4) | | | | | |
| Turn-off Threshold | V_{thoff} | GND | - | 0.5 | Vdc |
| Turn-on Threshold | V_{thon} | 2.5 | - | V_{in} | Vdc |
| Impedance to V_{in} | R_{Enable} | - | 10 | - | kOhms |

Specifications subject to change without notice.

(Note 1) Surface temperature must not exceed 80 degrees C; thermal management actions may be required.

(Note 2) Input current in excess of maximum may indicate a load/inverter mismatch condition, which can result in reduced reliability. Please contact ERG technical support.

(Note 3) Provided data is not tested but guaranteed by design.

(Note 4) The inverter is always enabled with an internal pullup resistor tied to the enable pin. A ground on the enable input will turn the inverter off.

Application Notes:

- 1) The minimum distance from high voltage areas of the inverter to any conductive material should be .12 inches per kilovolt of starting voltage.
- 2) Mounting hardware to be non-conductive.
- 3) Open framed inverters should not be used in applications at altitudes over 10,000 feet.
- 4) ACreturn should be left floating, not grounded.
- 5) Contact ERG for possible exceptions.



Onboard PWM

Unless otherwise noted $V_{in} = 5.00$ Volts DC, $T_a = 25$ °C and unit has been running for 5 minutes.

| Characteristic | Symbol | Min | Typ | Max | Units |
|----------------------------|-------------|-----|-----|-----|---------|
| Frequency | f_{pwm} | - | 160 | - | Hz |
| Control Input Bias Current | I_{cbias} | - | - | 10 | μA |

Pin Descriptions

+Vin Input voltage to the inverter.

GND Inverter ground.

Control Analog voltage input to the onboard pulse width modulator. Increasing this voltage increases the off time of the onboard PWM resulting in decreased brightness. The inverter is full on when this voltage is near inverter ground.

Enable Inverter Enable. The inverter is always enabled with an internal pullup resistor tied to the enable pin. Pull this pin low to disable inverter operation. The onboard PWM is always utilized.

Application information

The 10mD series of inverters is designed to power one cold cathode fluorescent lamp with six watts. An external analog control interfaces with an onboard pulse width modulator to provide dimming control. The 10mD inverter can reliably dim to less than 5% duty cycle.

External shutdown of the inverter is accomplished using the Enable pin. Pulling this pin low (below V_{thoff}) disables the inverter.

If analog voltage dimming is required, the analog voltage is applied to the Control pin. Figure 1 shows how to connect the inverter for onboard PWM operation. Graph 1 shows the relationship of PWM duty cycle to input control voltage.

If an external PWM is used, simply connect the Enable pin to the PWM source and connect the Control pin to inverter ground. If the onboard PWM is used, connect the analog voltage to the Control pin.



Control Voltage vs. Duty Cycle

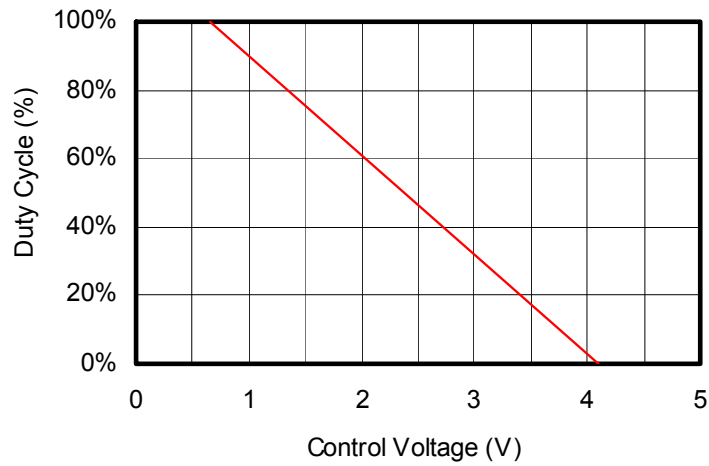

Graph 1

Typical Application

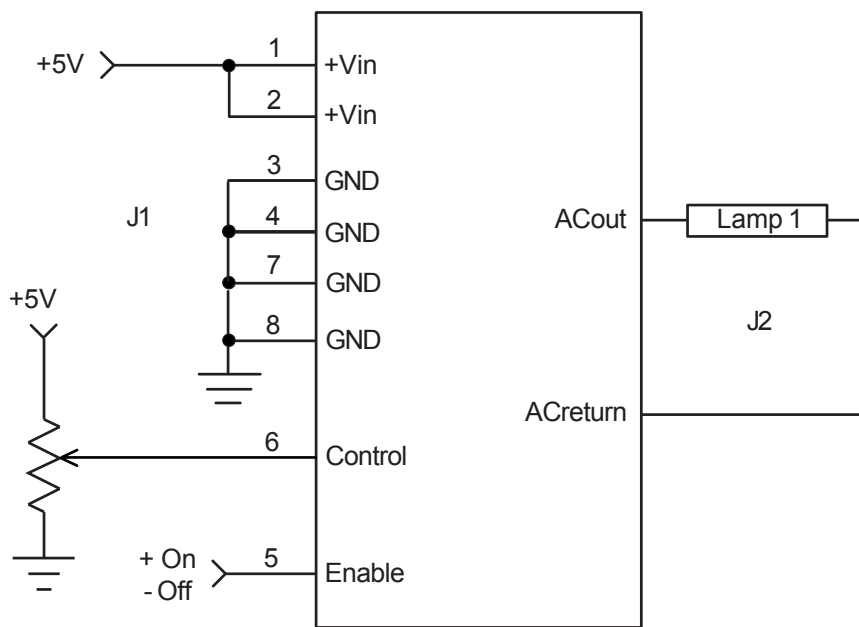

Figure 1



Endicott Research Group, Inc. (ERG) reserves the right to make changes in circuit design and/or specifications at any time without notice. Accordingly, the reader is cautioned to verify that data sheets are current before placing orders. Information furnished by ERG is believed to be accurate and reliable. However, no responsibility is assumed by ERG for its use.