



Endicott Research Group, Inc.

2601 Wayne St., Endicott, NY 13760

607-754-9187 Fax 607-754-9255

http://www.ergpower.com

# 10mA3450

## Specifications and Applications Information

11/13/08

Preliminary

### 10m Class DC to AC Inverter

The ERG (10m Class) low profile dc to ac inverter is specifically designed to power the the following display module(s) to a moderate brightness level.

- Vertex LVM104SD CCFL display from a +12 volt dc power supply.

This low profile inverter features:

- ✓ Less Than 10 mm in Height
- ✓ LCD Module Specific
- ✓ Display Compatible Output Connector
- ✓ Firm Specifications
- ✓ Application Information
- ✓ Designed, Manufactured and Supported in the USA
- ✓ Custom Input and Output Voltages
- ✓ Flexible System Interface

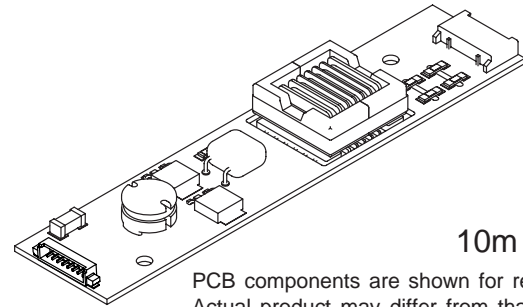

10m Package

PCB components are shown for reference only. Actual product may differ from that shown.

### Package Configuration

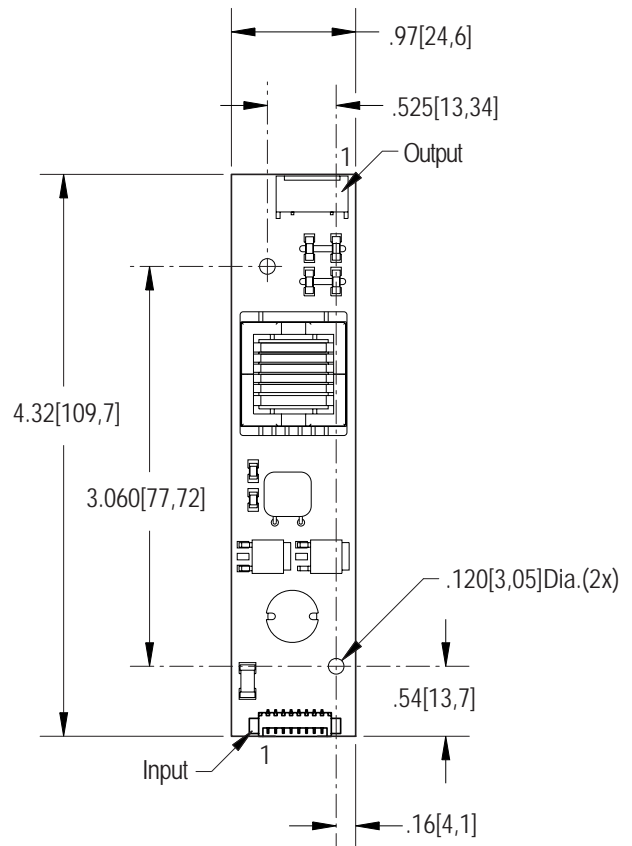

Mass: 22 grams

PCB components are shown for reference only. Actual product may differ from that shown.

### Connectors

Input Connector	Output Connector
Molex 53261-0890	JST SM03(4.0)B-BHS-1-TB
J1-1 Vin(+) J1-2 Vin(+) J1-3 GND J1-4 GND J1-5 Enable * J1-6 N/C J1-7 N/C J1-8 N/C	J2-1 ACout J2-2 ACout J2-3 ACreturn

\* Valid only with JP1 removed.

# 10mA3450

## Absolute Maximum Ratings

Rating	Symbol	Value	Units
Input Voltage Range	Vin	-0.3 to +13.2	Vdc
Storage Temperature	Tstg	-40 to +85	°C

## Operating Characteristics

With a load simulating the referenced display and lamp warm-up of 5 minutes.  
Unless otherwise noted Vin = 12.00 Volts dc and Ta = 25°C

Characteristic	Symbol	Min	Typ	Max	Units
Input Voltage	Vin	+11.8	+12.0	+12.6	Vdc
Component Surface Temperature	Ts	-20	-	+80	°C
Input Current <sup>(note 1)</sup>	Iin	-	.37	.43	Adc
Operating Frequency	Fo	29	34	39	KHz
Minimum Output Voltage	Vout (min)	1300	-	-	Vrms
Efficiency	-	-	90	-	%
Output Current (per lamp)	Iout	-	7	-	marms
Output Voltage	Vout	-	580	-	Vrms
Enable Pin Input Current Requirement <sup>(note 2)</sup>	Iin	-	3.6	-	madc
Enable Pin Input Voltage Requirement <sup>(note 2)</sup>	Vin	<b>Off</b> 0 or Floating	<b>On</b> 12	<b>On</b> 13.2	Vdc

Specifications subject to change without notice.

(Note 1) Input current in excess of maximum may indicate a load/inverter mismatch condition, which can result in reduced reliability. Please contact ERG technical support.

(Note 2) Valid only with JP1 removed. See Recommended User Disable/Interface Circuit on page 3.

### Application Notes:

- 1) The minimum distance from high voltage areas of the inverter to any conductive material should be .12 inches per kilovolt of starting voltage.
- 2) Mounting hardware should be non-conductive.
- 3) Open framed inverters should not be used in applications at altitudes over 10,000 feet.
- 4) Contact ERG for possible exceptions.



Endicott Research Group, Inc.

2601 Wayne St., Endicott, NY 13760  
607-754-9187 Fax 607-754-9255  
<http://www.ergpower.com>

Made in USA



## PWM Dimming

(Valid only with JP1 removed)

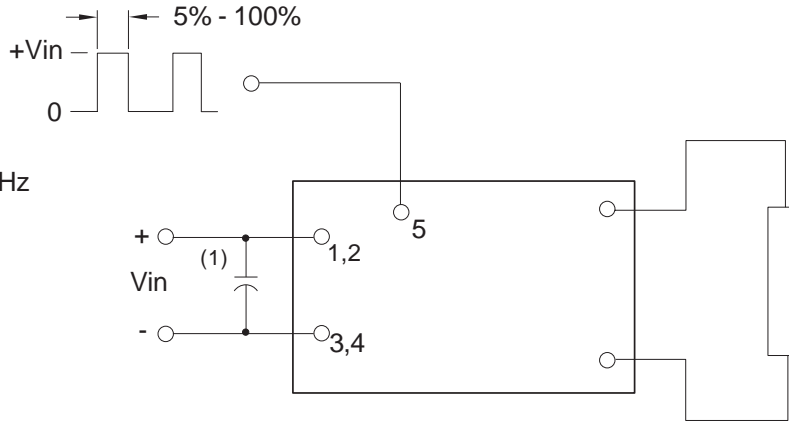

PWM frequency 100-300Hz should be selected to be compatible with LCD and display driver.

(1) Low ESR type input by-pass capacitor (22 uf - 100 uf) may be required to reduce reflected ripple.

## Recommended User Disable/Interface Circuit

Circuit or equivalent required with JP1 removed for proper inverter turnoff.

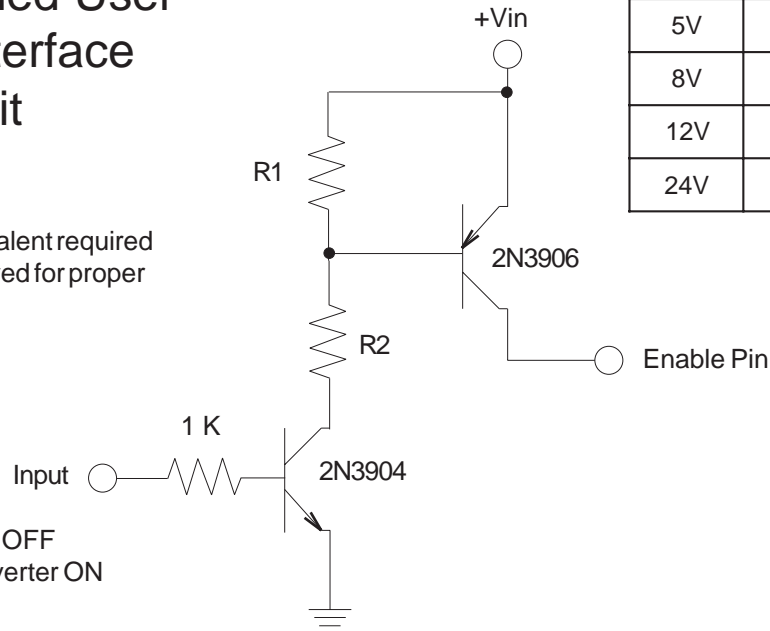

Vin	R1	R2
5V	3.3K	1.5K
8V	3.3K	1.8K
12V	3.3K	2.2K
24V	10.0K	8.2K

0-0.5V Inverter OFF  
2.0V - 12.6V Inverter ON



Endicott Research Group, Inc. (ERG) reserves the right to make changes in circuit design and/or specifications at any time without notice. Accordingly, the reader is cautioned to verify that data sheets are current before placing orders. Information furnished by ERG is believed to be accurate and reliable. However, no responsibility is assumed by ERG for its use.