



Endicott Research Group, Inc.

2601 Wayne St., Endicott, NY 13760  
 607-754-9187 Fax 607-754-9255  
<http://www.ergpower.com>

# 10m123955

## Specifications and Applications Information

10/17/11

**10m Class**  
 Single Lamp  
 DC to AC Inverter

The ERG 10m123955 (10m Class) low profile dc to ac inverter is specifically designed to power the following display backlight(s) to a moderate brightness level from a +12 Volt dc power supply:

- Toshiba LTA085C185F

This low profile inverter features:

- ✓ Less Than 10 mm in Height
- ✓ LCD Module Specific
- ✓ Display Compatible Output Connector
- ✓ Firm Specifications
- ✓ Application Information
- ✓ Designed, Manufactured and Supported in the USA
- ✓ Custom Input and Output Voltages
- ✓ Flexible System Interface

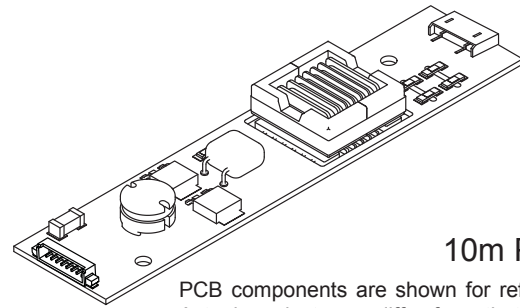

**10m Package**

PCB components are shown for reference only. Actual product may differ from that shown.

### Package Configuration

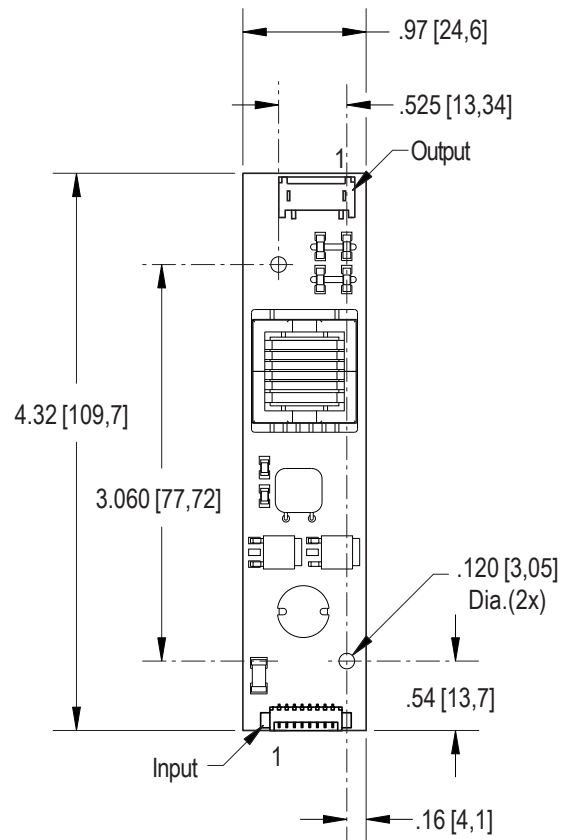

PCB components are shown for reference only. Actual product may differ from that shown.



Mass: 22 grams

Connectors	
<b>Input Connector</b> Molex 53261-0871	<b>Output Connector</b> JST SM02(8.0)B-BHS-1-TB
J1-1,2 +Vin J1-3,4 GND J1-5 Enable J1-6,7,8 N/C	J2-1 ACout J2-2 ACreturn

**Absolute Maximum Ratings**

Rating	Symbol	Value	Units
Input Voltage Range	$V_{in}$	-0.3 to +13.2	Vdc
Storage Temperature	$T_{stg}$	-40 to +85	°C

**Operating Characteristics**

With the referenced display and lamp warm-up of 5 minutes.  
Unless otherwise noted  $V_{in} = 12.00$  Volts dc and  $T_a = 25^{\circ}\text{C}$

Characteristic	Symbol	Min	Typ	Max	Units
Input Voltage	$V_{in}$	+10.8	+12.0	+12.6	Vdc
Component Surface Temperature (note 1)	$T_s$	-20	-	+80	°C
Input Current (note 2)	$I_{in}$	-	0.37	0.43	Adc
Operating Frequency	$F_o$	39	44	49	kHz
Minimum Output Voltage (note 3)	$V_{out}(\text{min})$	1800	-	-	Vrms
Efficiency (note 4)	$\eta$	-	93	-	%
Output Current (per lamp)	$I_{out}$	-	6.5	-	mArms
Output Voltage	$V_{out}$	-	665 / 630	-	Vrms
Enable Pin Input Current Requirement (note 5)	$I_{enable}$	-	4.0	-	mAdc
Enable Pin Input Voltage Requirement (note 5)	$V_{enable}$	<b>Off</b> 0 or Floating	<b>On</b> 12	<b>On</b> $V_{in}$	Vdc

Specifications subject to change without notice.

(Note 1) Surface temperature must not exceed 80 degrees C; thermal management actions may be required.

(Note 2) Input current in excess of maximum may indicate a load/inverter mismatch condition, which can result in reduced reliability. Please contact ERG technical support.

(Note 3) Provided data is not tested but guaranteed by design.

(Note 4)  $V_{out} = 630$  Vrms used for efficiency calculation.

(Note 5) Required User Enable/Disable Interface Circuit is shown on page 3.

**Application Notes:**

- 1) The minimum distance from high voltage areas of the inverter to any conductive material should be .12 inches per kilovolt of starting voltage.
- 2) Mounting hardware to be non-conductive.
- 3) Open framed inverters should not be used in applications at altitudes over 10,000 feet.
- 4) ACreturn should be left floating, not grounded.
- 5) Contact ERG for possible exceptions.



**Endicott Research Group, Inc.**

2601 Wayne St., Endicott, NY 13760  
607-754-9187 Fax 607-754-9255  
<http://www.ergpower.com>

Made in USA

## PWM Dimming

Circuit or equivalent required for proper inverter turnoff.

PWM frequency 100-300 Hz should be selected to be compatible with LCD and display driver.

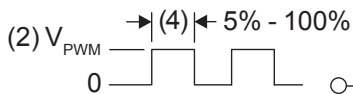

### Required User Enable/Disable Interface Circuit

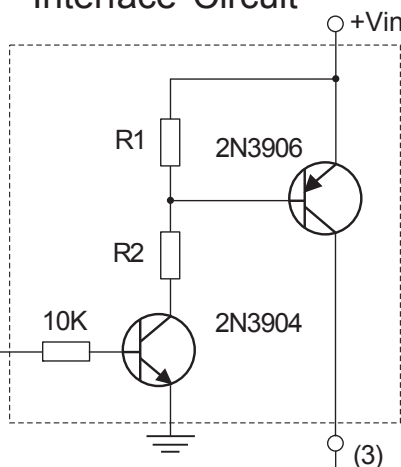

V <sub>in</sub>	R1	R2
5V	3.3K	1.5K
8V	3.3K	1.8K
12V	3.3K	2.2K
24V	10.0K	8.2K

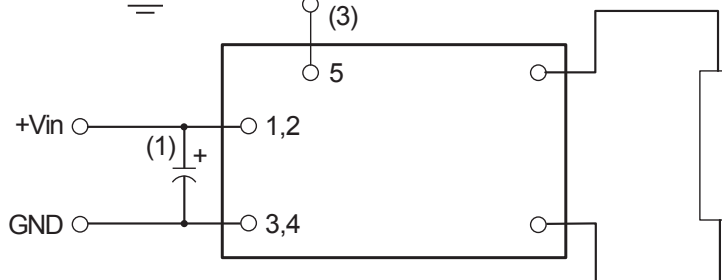

- (1) Low ESR type input by-pass capacitor (22 uF - 100 uF) may be required to reduce reflected ripple.
- (2) V<sub>PWM</sub> from 2.4V to less than or equal to +Vin.
- (3) Full brightness without PWM control requires that pin 5 be tied to +Vin. Pin 5 must be at 0V to turn off.
- (4) Duty Cycle 5% - 100%.



Endicott Research Group, Inc. (ERG) reserves the right to make changes in circuit design and/or specifications at any time without notice. Accordingly, the reader is cautioned to verify that data sheets are current before placing orders. Information furnished by ERG is believed to be accurate and reliable. However, no responsibility is assumed by ERG for its use.