



Endicott Research Group, Inc.

2601 Wayne St., Endicott, NY 13760

607-754-9187 Fax 607-754-9255

http://www.ergpower.com

10m123618F



Specifications and Applications Information

02/15/11

10m Class
Single Lamp
DC to AC Inverter

The ERG 10m123618F (10m Class) low profile dc to ac inverter is specifically designed to power the following display module(s) to a moderate brightness level from a +12 volt dc power supply:

- Hitachi TX18D16VM1CAB
- Hitachi TX18D16VM1CAA

This low profile inverter features:

- ✓ Less Than 10 mm in Height
- ✓ LCD Module Specific
- ✓ Display Compatible Output Connector
- ✓ Firm Specifications
- ✓ Application Information
- ✓ Designed, Manufactured and Supported in the USA
- ✓ Custom Input and Output Voltages
- ✓ Flexible System Interface

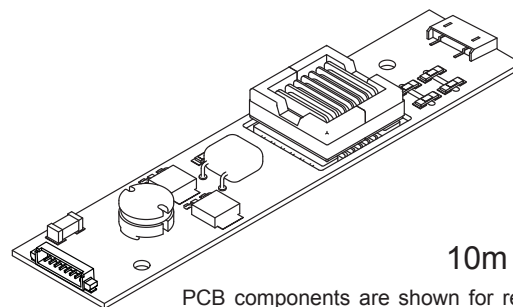

PCB components are shown for reference only. Actual product may differ from that shown.

Package Configuration

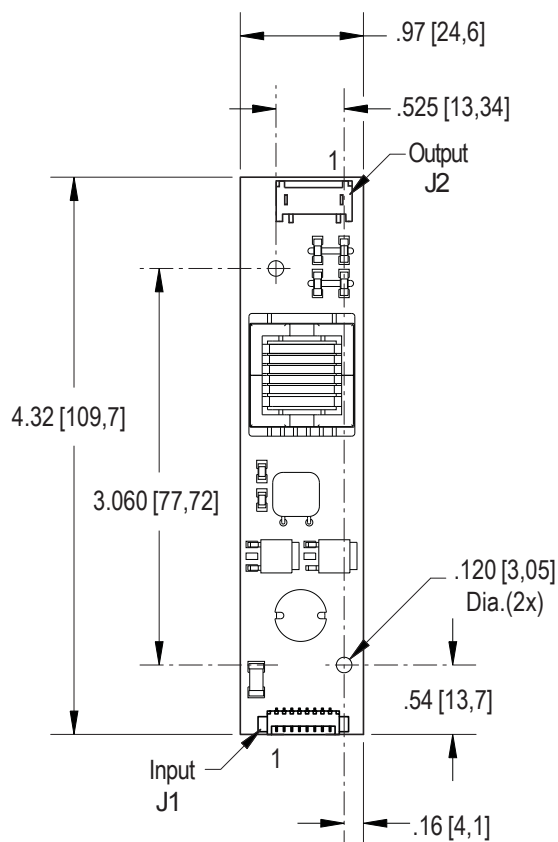

Mass: 22 grams

PCB components are shown for reference only. Actual product may differ from that shown.

Connectors

Input Connector		Output Connector	
Molex		JST	
53261-0871		SM02(8.0)B-BHS-1-TB	
J1-1,2	+Vin	J2-1	ACout
J1-3,4	GND	J2-2	ACreturn
J1-5	Enable		
J1-6,7,8	N/C		

Absolute Maximum Ratings

Rating	Symbol	Value	Units
Input Voltage Range	V_{in}	-0.3 to +13.2	Vdc
Storage Temperature	T_{stg}	-40 to +85	°C

Operating Characteristics

With the referenced display and lamp warm-up of 5 minutes.
Unless otherwise noted $V_{in} = 12.00$ Volts dc and $T_a = 25^\circ\text{C}$

Characteristic	Symbol	Min	Typ	Max	Units
Input Voltage	V_{in}	+10.8	+12.0	+12.6	Vdc
Component Surface Temperature (note 1)	T_s	-20	-	+80	°C
Input Current (note 2)	I_{in}	-	0.28	0.32	Adc
Operating Frequency	F_o	26	31	36	kHz
Minimum Output Voltage (note 3)	$V_{out}(\text{min})$	2300	-	-	Vrms
Efficiency	η	-	90	-	%
Output Current (per lamp)	I_{out}	-	3.0	-	mArms
Output Voltage	V_{out}	-	1000	-	Vrms
Enable Pin Input Current Requirement (note 4)	I_{Enable}	-	5.4	-	mAdc
Enable Pin Input Voltage Requirement (note 4)	V_{Enable}	Off 0 or Floating	On 12	On V_{in}	Vdc

Specifications subject to change without notice.

(Note 1) Surface temperature must not exceed 80 degrees C; thermal management actions may be required.

(Note 2) Input current in excess of maximum may indicate a load/inverter mismatch condition, which can result in reduced reliability. Please contact ERG technical support.

(Note 3) Provided data is not tested but guaranteed by design.

(Note 4) Required User Enable/Disable Interface Circuit is shown on page 3.

Application Notes:

- 1) The minimum distance from high voltage areas of the inverter to any conductive material should be .12 inches per kilovolt of starting voltage.
- 2) Mounting hardware to be non-conductive.
- 3) Open framed inverters should not be used in applications at altitudes over 10,000 feet.
- 4) ACreturn should be left floating, not grounded.
- 5) Contact ERG for possible exceptions.



Endicott Research Group, Inc.

2601 Wayne St., Endicott, NY 13760
607-754-9187 Fax 607-754-9255
<http://www.ergpower.com>

Made in USA



PWM Dimming

Circuit or equivalent required for proper inverter turnoff.

PWM frequency 100-300 Hz should be selected to be compatible with LCD and display driver.

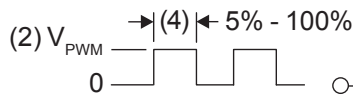

Required User Enable/Disable Interface Circuit

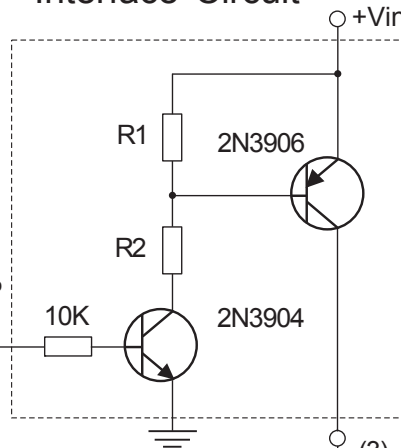

Vin	R1	R2
5V	3.3K	1.5K
8V	3.3K	1.8K
12V	3.3K	2.2K
24V	10.0K	8.2K

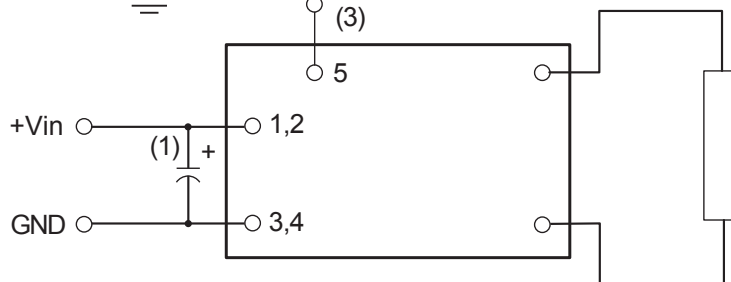

- (1) Low ESR type input by-pass capacitor (22 uF - 100 uF) may be required to reduce reflected ripple.
- (2) V_{PWM} from 2.4V to less than or equal to +Vin.
- (3) Full brightness without PWM control requires that pin 5 be tied to +Vin. Pin 5 must be at 0V to turn off.
- (4) Duty Cycle 5% - 100%.



Endicott Research Group, Inc. (ERG) reserves the right to make changes in circuit design and/or specifications at any time without notice. Accordingly, the reader is cautioned to verify that data sheets are current before placing orders. Information furnished by ERG is believed to be accurate and reliable. However, no responsibility is assumed by ERG for its use.